



RXP 800

# PARTI DI RICAMBIO

SPARE LISTS

RXP – SERIE 800

NGQ16\_RXP

Del 30/07/2012

1

STM spa

VIA DEL MACCABRECCIA , 39  
40012 - CALDERARA DI RENO (BO) ITALY

E-mail: [stm@stmspa.com](mailto:stm@stmspa.com)

TEL ++ 39.051.6467711 FAX . ++ 39.051.6466178



LISTA PARTI DI RICAMBIO



SPARE LISTS

In questo documento sono contenute tutte le istruzioni relative alle modalità di richiesta delle Parti di Ricambio dei Riduttori RXP SERIE 800 GSM.

Attenzione

Verificare la revisione in vostro possesso e la tabella degli aggiornamenti apportati nelle nuova revisione

MODALITA' OPERATIVE

GENERALITA'

La Tab.RPR indica i dati che è indispensabile fornire in fase di richiesta Parti di Ricambio per poter effettuare una corretta identificazione del prodotto e di conseguenza una sollecita risposta alla richiesta stessa.

In particolare si richiede:

- 1) Compilare il modulo "Richiesta Parti di Ricambio" riportato in Tab. RPR;
- 2) Inviarlo via Fax al nr. sopra indicato;
- 3) Attendere Fax di conferma da parte della GSM S.p.a.

*This document is about the procedure to request spare parts of RXP SERIE 800 GSM.*

Notice :

Please check the revision in your possession as well as the table reporting all the updates in the new revision

PROCEDURE :

*The chart RPR shows the data needed when requesting spare parts in order to enable a correct product identification and consequently a quick reply to the inquiry. Please provide :*

- 1) *The form " Spare part request " shown in Tab. RPR duly filled in.*
- 2) *Fax it to the number above given.*
- 3) *Wait for the return confirmatiopn fax by GSM S.p.a*

MODALITA' COMPILAZIONE MODULO

Dalla targhetta applicata sul prodotto GSM trascrivere:

Work Order (W.O. NUMBER)

Designazione del prodotto

Dalla Tavole III, IV, V, VI, VII, VIII, IX, X, XI ricavare:

Ref. del componente da richiedere;

Descrizione del componente da richiedere

HOW TO FILL THE FORM IN :

*From the nameplate on the GSM product copy on the form :*

*Work Order (W.O. NUMBER)*

*Product designation*

*From the charts III, IV, V, VI, VII, VIII, IX, X, XI define :*

*Reference of the spare part to request*

*Full description of the spare part to request*

## Aggiornamenti apportati - Update table

Pagina Page	Paragrafo Chapter	Indice Revisione Index Updates	Descrizione - Description



## TAVOLA 0

### TAV. 0

N° Tav.	Descrizione - Description	Page
Tav. III	Cassa-Casing - RX.1-RX.2-RX.3	03
Tav. IV	Entrata-Input- RXP	06
Tav. V	Uscite - Output	08
Tav. VI	Alberi Interni - Shafts 2 - 3	10
Tav. VII	Flange Uscita - Output Flanges	12
Tav. VIII	Ventole - Fans	14
Tav. IX	Antiretro - Backstop	16
Tav. X	Cassa-Casing - RX.4	18
Tav. XI	Albero Interni -Shaft 1	21

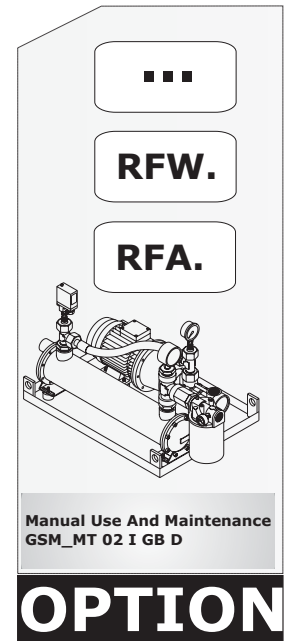
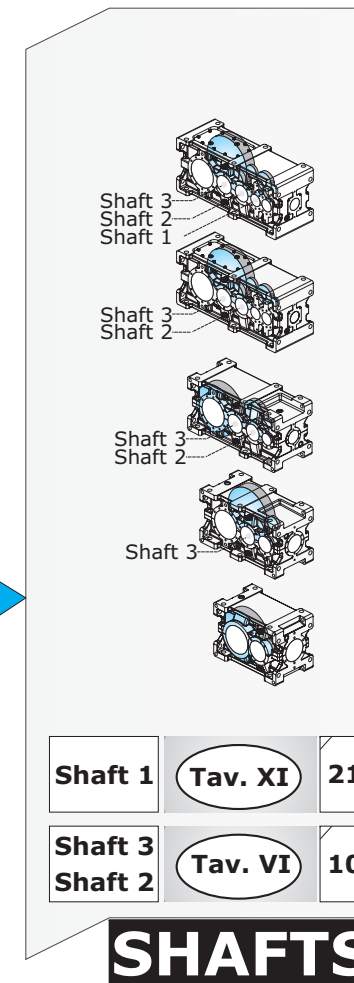
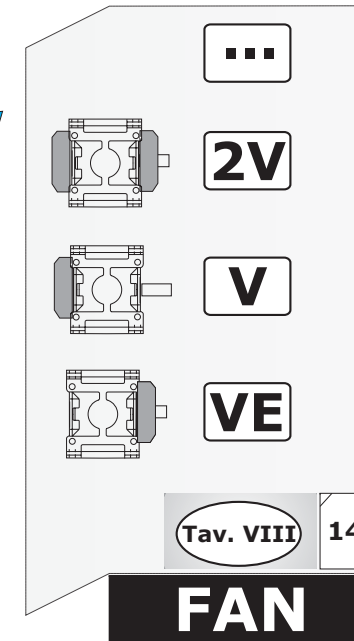
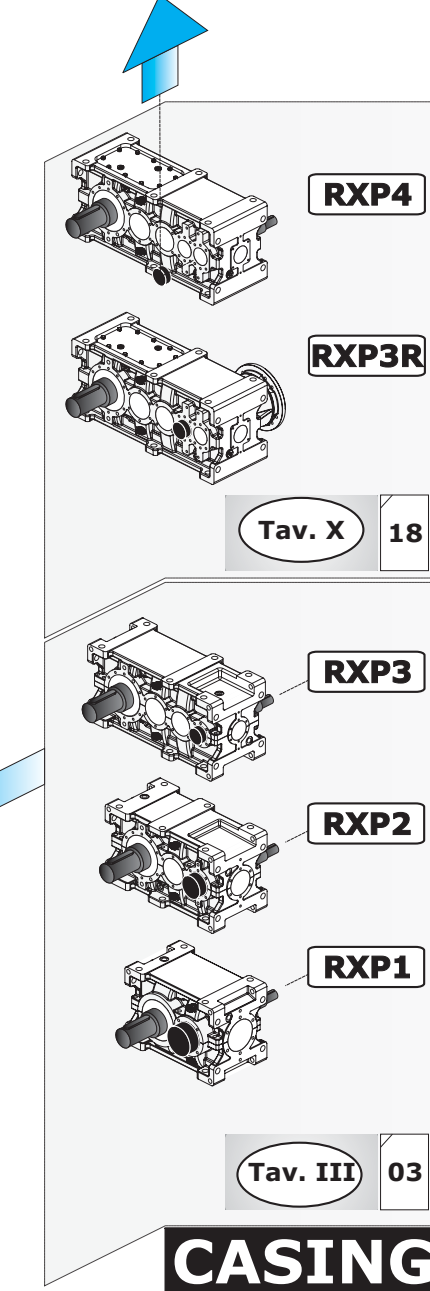
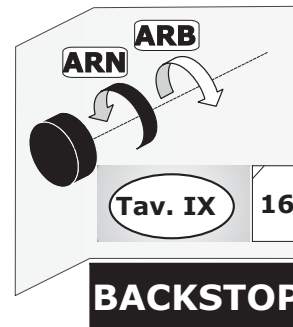
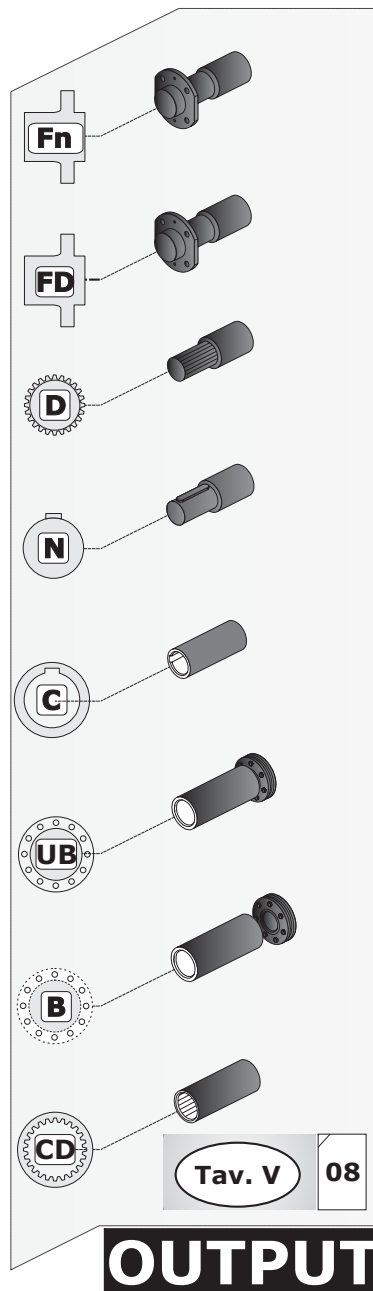
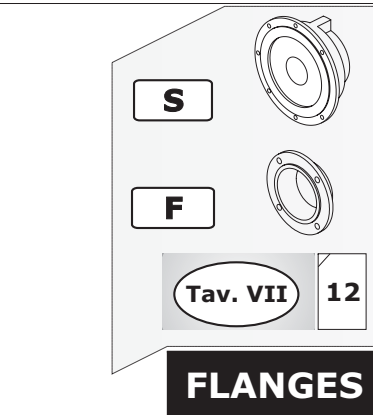
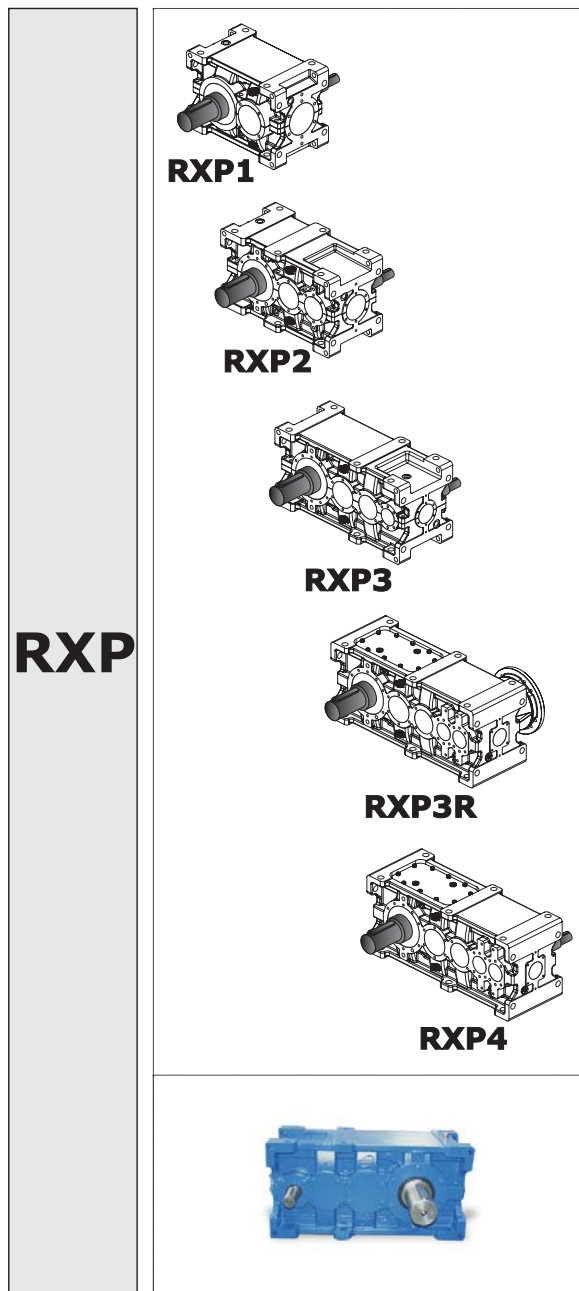



# TAVOLA III

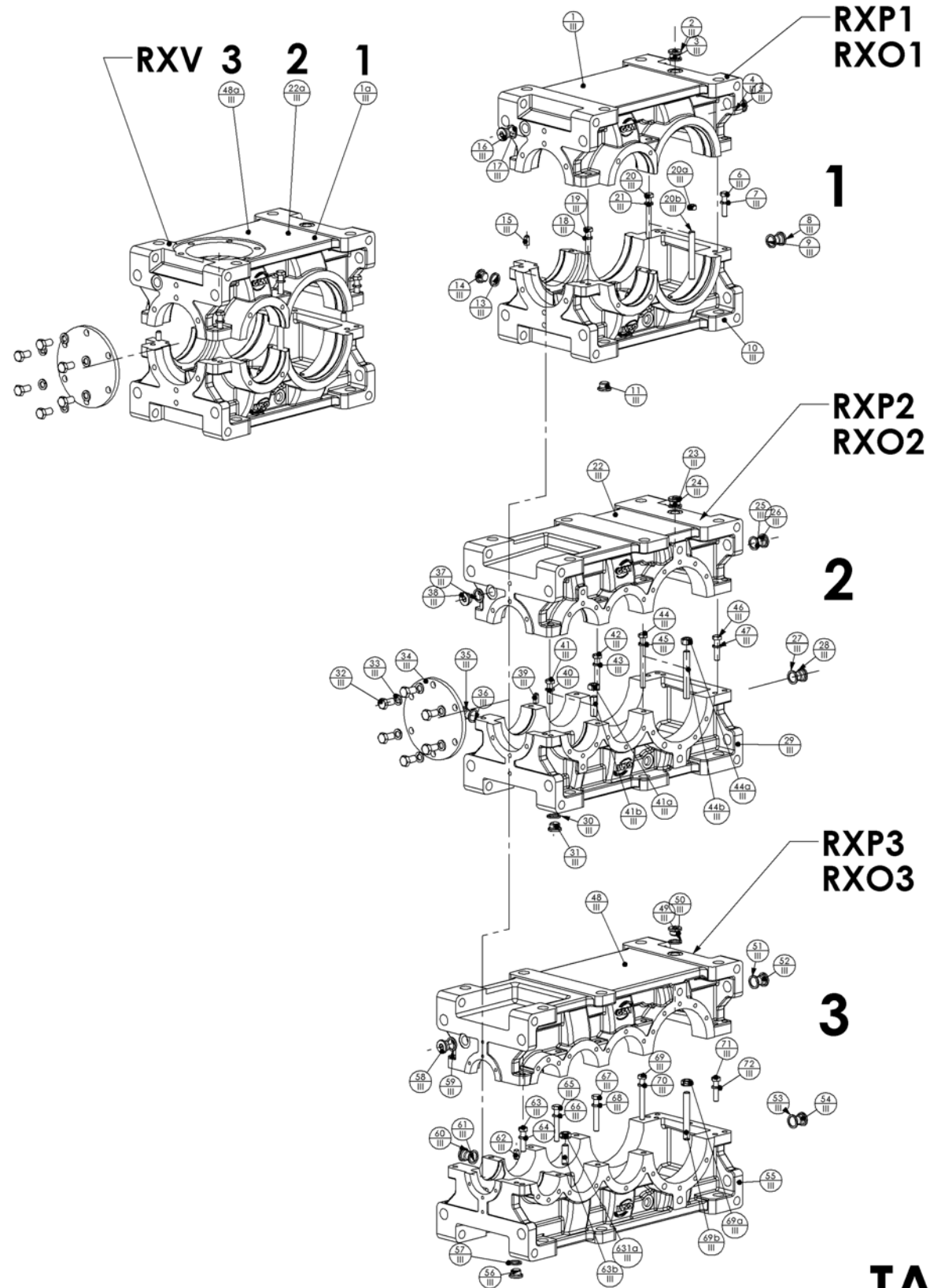

# TAVOLA III



RXP 800

# PARTI DI RICAMBIO

SPARE LISTS

RXP - SERIE 800

NGQ16\_RXP

Del 30/07/2012

4

STM spa

VIA DEL MACCABRECCIA, 39  
40012 - CALDERARA DI RENO (BO) ITALY  
E-mail: [stm@stmspa.com](mailto:stm@stmspa.com)

TEL ++ 39.051.6467711 FAX . ++ 39.051.6466178

## TAVOLA III

ITEM	TAVOLA	DESCRIZIONE ( I )	DESCRIPTION ( GB )	DESIGNATION ( F )	BEZEICHNUNG ( D )
1	III	COPERCHIO	COVER	COUVERCLE	DECKEL
1 a	III	COPERCHIO RXV	COVER RXV	COUVERCLE RXV	DECKEL RXV
2	III	TAPPO	PLUG	BOUCHON	VERSCHLUSS
3	III	GUARNIZIONE	GASKET	JOINT PAPIER	DICHTUNG
4	III	GUARNIZIONE	GASKET	JOINT PAPIER	DICHTUNG
5	III	TAPPO	PLUG	BOUCHON	VERSCHLUSS
6	III	VITE DI FISSAGGIO	SCREW	VIS	BEFESTIGUNGSSCHRAUBE
7	III	GROWER	SPRING WASHER	RONDELLE FREIN	FEDERRING
8	III	TAPPO	PLUG	BOUCHON	VERSCHLUSS
9	III	GUARNIZIONE	GASKET	JOINT PAPIER	DICHTUNG
10	III	CASSA			
11	III	TAPPO	PLUG	BOUCHON	VERSCHLUSS
12	III	VITE DI FISSAGGIO	SCREW	VIS	BEFESTIGUNGSSCHRAUBE
13	III	GUARNIZIONE	GASKET	JOINT PAPIER	DICHTUNG
14	III	TAPPO	PLUG	BOUCHON	VERSCHLUSS
15	III	SPINA	PIN	GOUPILLE	STIFT
16	III	TAPPO	PLUG	BOUCHON	VERSCHLUSS
17	III	GUARNIZIONE	GASKET	JOINT PAPIER	DICHTUNG
18	III	GROWER	SPRING WASHER	RONDELLE FREIN	FEDERRING
19	III	VITE DI FISSAGGIO	SCREW	VIS	BEFESTIGUNGSSCHRAUBE
20	III	VITE DI FISSAGGIO	SCREW	VIS	BEFESTIGUNGSSCHRAUBE
20 a	III	DADO	NUT	ECROU	MUTTER
20 b	III	PRIGIONIERO	STUD	PRISONNIER	STIFTSCHRAUBE
21	III	GROWER	SPRING WASHER	RONDELLE FREIN	FEDERRING
22	III	COPERCHIO	COVER	COUVERCLE	DECKEL
22 a	III	COPERCHIO RXV	COVER RXV	COUVERCLE RXV	DECKEL RXV
23	III	TAPPO	PLUG	BOUCHON	VERSCHLUSS
24	III	GUARNIZIONE	GASKET	JOINT PAPIER	DICHTUNG
25	III	GUARNIZIONE	GASKET	JOINT PAPIER	DICHTUNG
26	III	TAPPO	PLUG	BOUCHON	VERSCHLUSS
27	III	GUARNIZIONE	GASKET	JOINT PAPIER	DICHTUNG
28	III	TAPPO	PLUG	BOUCHON	VERSCHLUSS
29	III	CASSA			
30	III	GUARNIZIONE	GASKET	JOINT PAPIER	DICHTUNG
31	III	TAPPO	PLUG	BOUCHON	VERSCHLUSS
32	III	VITE DI FISSAGGIO	SCREW	VIS	BEFESTIGUNGSSCHRAUBE
33	III	GROWER	SPRING WASHER	RONDELLE FREIN	FEDERRING
34	III	COPERCHIO CHIUSO	CLOSED COVER	COUVERCLE FERME'	ABSCHLUSSDECKEL SCHNECKENWELLE RMI/RI
35	III	TAPPO	PLUG	BOUCHON	VERSCHLUSS
36	III	GUARNIZIONE	GASKET	JOINT PAPIER	DICHTUNG
37	III	GUARNIZIONE	GASKET	JOINT PAPIER	DICHTUNG
38	III	TAPPO	PLUG	BOUCHON	VERSCHLUSS
39	III	SPINA	PIN	GOUPILLE	STIFT
40	III	GROWER	SPRING WASHER	RONDELLE FREIN	FEDERRING
41	III	VITE DI FISSAGGIO	SCREW	VIS	BEFESTIGUNGSSCHRAUBE



RXP 800

# PARTI DI RICAMBIO

## SPARE LISTS

RXP – SERIE 800

NGQ16\_RXP  
Del 30/07/2012

5

STM spa  
VIA DEL MACCABRECCIA , 39  
40012 - CALDERARA DI RENO (BO) ITALY  
E-mail: [stm@stmspa.com](mailto:stm@stmspa.com)  
TEL ++ 39.051.6467711 FAX . ++ 39.051.6466178

### TAVOLA III

ITEM	TAVOLA	DESCRIZIONE ( I )	DESCRIPTION ( GB )	DESIGNATION ( F )	BEZEICHNUNG ( D )
41 a	III	DADO	NUT	ECROU	MUTTER
41 b	III	PRIGIONIERO	STUD	PRISONNIER	STIFTSCHRAUBE
42	III	VITE DI FISSAGGIO	SCREW	VIS	BEFESTIGUNGSSCHRAUBE
43	III	GROWER	SPRING WASHER	RONDELLE FREIN	FEDERRING
44	III	VITE DI FISSAGGIO	SCREW	VIS	BEFESTIGUNGSSCHRAUBE
44 a	III	DADO	NUT	ECROU	MUTTER
44 b	III	PRIGIONIERO	STUD	PRISONNIER	STIFTSCHRAUBE
45	III	GROWER	SPRING WASHER	RONDELLE FREIN	FEDERRING
46	III	VITE DI FISSAGGIO	SCREW	VIS	BEFESTIGUNGSSCHRAUBE
47	III	GROWER	SPRING WASHER	RONDELLE FREIN	FEDERRING
48	III	COPERCHIO	COVER	COUVERCLE	DECKEL
48 a	III	COPERCHIO RXV	COVER RXV	COUVERCLE RXV	DECKEL RXV
49	III	GUARNIZIONE	GASKET	JOINT PAPIER	DICHTUNG
50	III	TAPPO	PLUG	BOUCHON	VERSCHLUSS
51	III	GUARNIZIONE	GASKET	JOINT PAPIER	DICHTUNG
52	III	TAPPO	PLUG	BOUCHON	VERSCHLUSS
53	III	GUARNIZIONE	GASKET	JOINT PAPIER	DICHTUNG
54	III	TAPPO	PLUG	BOUCHON	VERSCHLUSS
55	III	CASSA			
56	III	TAPPO	PLUG	BOUCHON	VERSCHLUSS
57	III	GUARNIZIONE	GASKET	JOINT PAPIER	DICHTUNG
58	III	TAPPO	PLUG	BOUCHON	VERSCHLUSS
59	III	GUARNIZIONE	GASKET	JOINT PAPIER	DICHTUNG
60	III	TAPPO	PLUG	BOUCHON	VERSCHLUSS
61	III	GUARNIZIONE	GASKET	JOINT PAPIER	DICHTUNG
62	III	SPINA	PIN	GOUPILLE	STIFT
63	III	VITE DI FISSAGGIO	SCREW	VIS	BEFESTIGUNGSSCHRAUBE
63 a	III	DADO	NUT	ECROU	MUTTER
63 b	III	PRIGIONIERO	STUD	PRISONNIER	STIFTSCHRAUBE
64	III	GROWER	SPRING WASHER	RONDELLE FREIN	FEDERRING
65	III	VITE DI FISSAGGIO	SCREW	VIS	BEFESTIGUNGSSCHRAUBE
66	III	GROWER	SPRING WASHER	RONDELLE FREIN	FEDERRING
67	III	VITE DI FISSAGGIO	SCREW	VIS	BEFESTIGUNGSSCHRAUBE
68	III	GROWER	SPRING WASHER	RONDELLE FREIN	FEDERRING
69	III	VITE DI FISSAGGIO	SCREW	VIS	BEFESTIGUNGSSCHRAUBE
69 a	III	DADO	NUT	ECROU	MUTTER
69 b	III	PRIGIONIERO	STUD	PRISONNIER	STIFTSCHRAUBE
70	III	GROWER	SPRING WASHER	RONDELLE FREIN	FEDERRING
71	III	VITE DI FISSAGGIO	SCREW	VIS	BEFESTIGUNGSSCHRAUBE
72	III	GROWER	SPRING WASHER	RONDELLE FREIN	FEDERRING



## TAVOLA IV

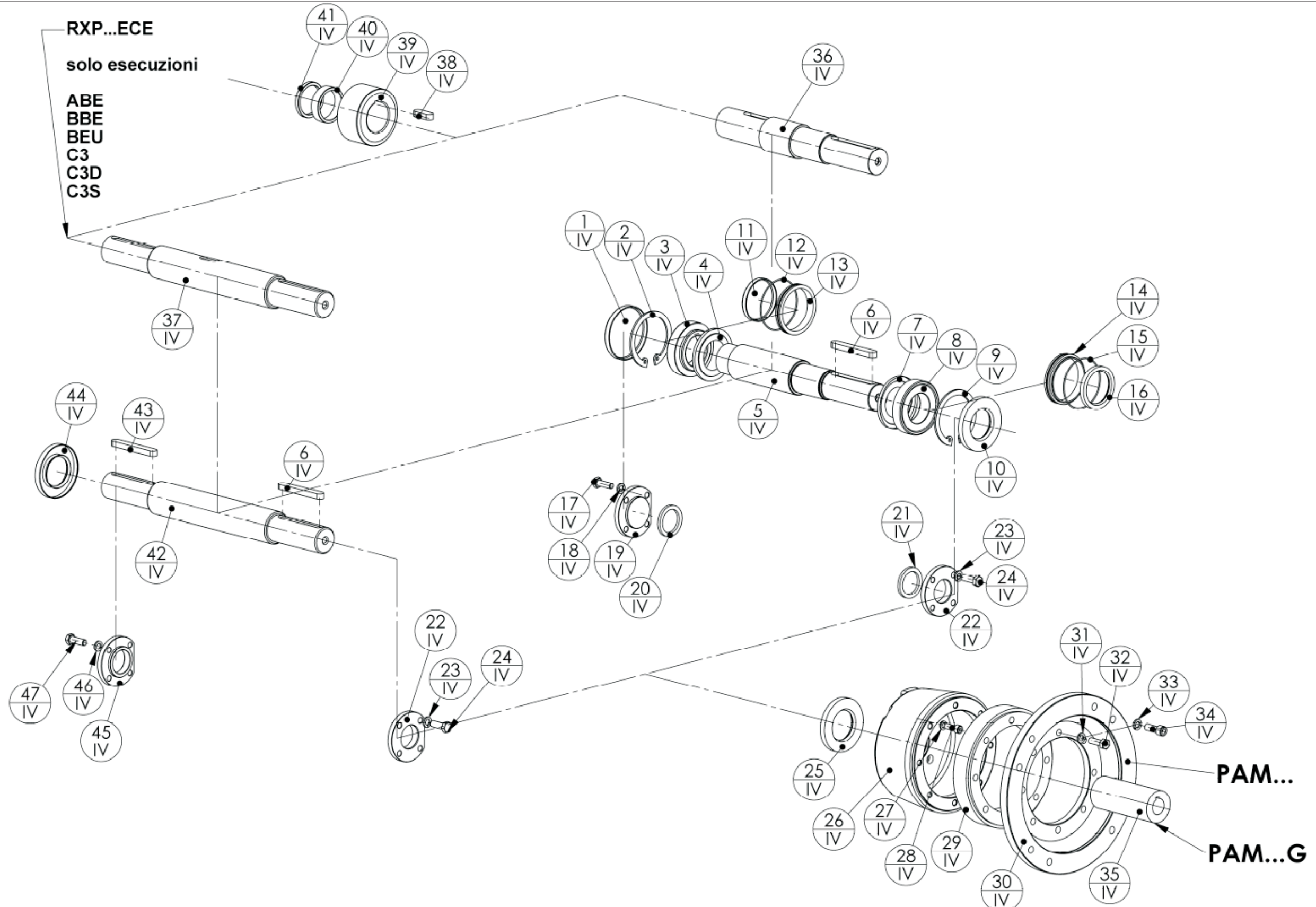



RXP 800

# PARTI DI RICAMBIO

## SPARE LISTS

RXP – SERIE 800

NGQ16\_RXP  
Del 30/07/2012

7

STM spa  
VIA DEL MACCABRECCIA , 39  
40012 - CALDERARA DI RENO (BO) ITALY  
E-mail: [stm@stmspa.com](mailto:stm@stmspa.com)  
TEL ++ 39.051.6467711 FAX . ++ 39.051.6466178

### TAVOLA IV

ITEM	TAVOLA	DESCRIZIONE ( I )	DESCRIPTION ( GB )	DESIGNATION ( F )	BEZEICHNUNG ( D )
1	IV	COPERCHIO IN GOMMA	RUBBER CAP	BOUCHON EN CAOUTCHOUC	GUMMIDECKEL
2	IV	SEEGER	CIRCLIP	CIRCLIP	SICHERUNGSRING
3	IV	CUSCINETTO	BEARING	ROULEMENT	WÄLZLAGER
4	IV	ANELLO NYLOS	RING NYLOS	BAGUE NYLOS	RING NYLOS
5	IV	ALBERO PIGNONE	PINION SHAFT	ARBRE PIGNON	RITZELWELLE
6	IV	LINGUETTA	KEY	CLAVETTE	PASSFEDER
7	IV	ANELLO NYLOS	RING NYLOS	BAGUE NYLOS	RING NYLOS
8	IV	CUSCINETTO	BEARING	ROULEMENT	WÄLZLAGER
9	IV	SEEGER	CIRCLIP	CIRCLIP	SICHERUNGSRING
10	IV	ANELLO DI TENUTA	OILSEAL	JOINT D'ETANCHEITE	ÖLDICHTRING
11	IV	TAPPO	PLUG	BOUCHON	VERSCHLUSS
12	IV	O - RING	O - RING	O - RING	O - RING
13	IV	ANELLO DI CENTRAGGIO	LOCATING RING	ANNEAU DE CENTRAGE	ZENTRIERRING
14	IV	ANELLO DI CENTRAGGIO	LOCATING RING	ANNEAU DE CENTRAGE	ZENTRIERRING
15	IV	O - RING	O - RING	O - RING	O - RING
16	IV	ANELLO DI TENUTA	OILSEAL	JOINT D'ETANCHEITE	ÖLDICHTRING
17	IV	VITE DI FISSAGGIO	SCREW	VIS	BEFESTIGUNGSSCHRAUBE
18	IV	GROWER	SPRING WASHER	RONDELLE FREIN	FEDERRING
19	IV	COPERCHIO CHIUSO	CLOSED COVER	COUVERCLE FERME'	ABSCHLUSSDECKEL SCHNECKENWELLE RMI/RI
20	IV	DISTANZIALE	SPACER RING	ENTRETOISE	DISTANZSCHEIBE
21	IV	DISTANZIALE	SPACER RING	ENTRETOISE	DISTANZSCHEIBE
22	IV	COPERCHIO APERTO	OPEN COVER	COUVERCLE OUVERT	DECKEL EINTRIEBSSEITE RI
23	IV	GROWER	SPRING WASHER	RONDELLE FREIN	FEDERRING
24	IV	VITE DI FISSAGGIO	SCREW	VIS	BEFESTIGUNGSSCHRAUBE
25	IV	ANELLO DI TENUTA	OILSEAL	JOINT D'ETANCHEITE	ÖLDICHTRING
26	IV	SUPPORTO FLAM	IEC FLANGE INPUT SUPPORT	SUPPORT BRIDE MOTEUR	AUFNAHME ANTRIEB IEC FLANSCH
27	IV	RONDELLA	WASHER	RONDELLE	UNTERLEGSCHNEIBE
28	IV	VITE DI FISSAGGIO	SCREW	VIS	BEFESTIGUNGSSCHRAUBE
29	IV	ANELLO DI CENTRAGGIO	LOCATING RING	ANNEAU DE CENTRAGE	ZENTRIERRING
30	IV	FLANGIA ATTACCO MOTORE	INPUT FLANGE	BRIDE MOTEUR	EINGANGSFLANSCH
31	IV	GROWER	SPRING WASHER	RONDELLE FREIN	FEDERRING
32	IV	VITE DI FISSAGGIO	SCREW	VIS	BEFESTIGUNGSSCHRAUBE
33	IV	RONDELLA	WASHER	RONDELLE	UNTERLEGSCHNEIBE
34	IV	VITE DI FISSAGGIO	SCREW	VIS	BEFESTIGUNGSSCHRAUBE
35	IV	GIUNTO	COUPLING	JOINT D' ACCOUPLEMENT	KUPPLUNG
36	IV	ALBERO ENTRATA	INPUT SHAFT	ARBRE ENTREE	ANTRIEBSWELLE
37	IV	ALBERO ENTRATA BISP	DOUBLE EXTENDED INPUT SHAFT	ARBRE ENTREE DOUBLE	DOPPELANTRIEBSWELLE
38	IV	LINGUETTA	KEY	CLAVETTE	PASSFEDER
39	IV	PIGNONE CILINDRICO ELIC.	HELICAL PINION	PIGNON CYL. HELYCOIDAL	RITZEL (STIRNRAD)
40	IV	DISTANZIALE	SPACER RING	ENTRETOISE	DISTANZSCHEIBE
41	IV	DISTANZIALE	SPACER RING	ENTRETOISE	DISTANZSCHEIBE
42	IV	ALBERO PIGNONE BISPORGENTE	DOUBLE PINION SHAFT		
43	IV	LINGUETTA	KEY	CLAVETTE	PASSFEDER
44	IV	ANELLO DI TENUTA	OILSEAL	JOINT D'ETANCHEITE	ÖLDICHTRING
45	IV	COPERCHIO APERTO	OPEN COVER	COUVERCLE OUVERT	DECKEL EINTRIEBSSEITE RI
46	IV	GROWER	SPRING WASHER	RONDELLE FREIN	FEDERRING
47	IV	VITE DI FISSAGGIO	SCREW	VIS	BEFESTIGUNGSSCHRAUBE



## TAVOLA V

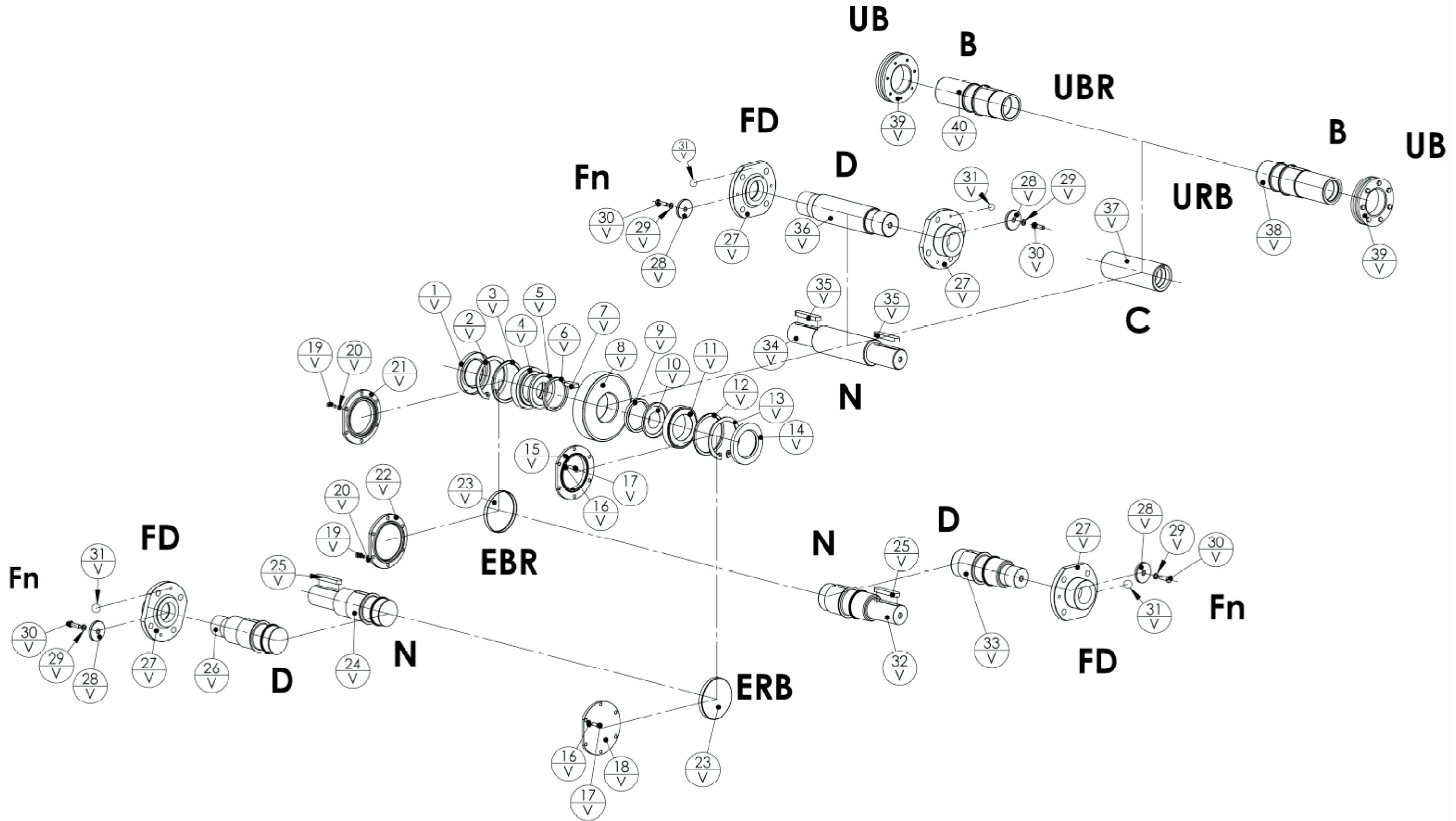





RXP 800

# PARTI DI RICAMBIO

## SPARE LISTS

RXP – SERIE 800

NGQ16\_RXP  
Del 30/07/2012

9

STM spa  
VIA DEL MACCABRECCIA , 39  
40012 - CALDERARA DI RENO (BO) ITALY  
E-mail: [stm@stmspa.com](mailto:stm@stmspa.com)  
TEL ++ 39.051.6467711 FAX . ++ 39.051.6466178

### TAVOLA V

ITEM	TAVOLA	DESCRIZIONE ( I )	DESCRIPTION ( GB )	DESIGNATION ( F )	BEZEICHNUNG ( D )
1	V	ANELLO DI TENUTA	OILSEAL	JOINT D'ETANCHEITE	ÖLDICHTRING
2	V	SEEGER	CIRCLIP	CIRCLIP	SICHERUNGSRING
3	V	DISTANZIALE	SPACER RING	ENTRETOISE	DISTANZSCHEIBE
4	V	CUSCINETTO	BEARING	ROULEMENT	WÄZLAGER
5	V	ANELLO NYLOS	RING NYLOS	BAGUE NYLOS	RING NYLOS
6	V	DISTANZIALE	SPACER RING	ENTRETOISE	DISTANZSCHEIBE
7	V	LINGUETTA	KEY	CLAVETTE	PASSFEDER
8	V	CORONA CILINDRICA ELIC.	HELICAL WHEEL	ROUE CYLINDR. HELICOIDALE	ZAHNRAD (STIRNRAD)
9	V	DISTANZIALE	SPACER RING	ENTRETOISE	DISTANZSCHEIBE
10	V	ANELLO NYLOS	RING NYLOS	BAGUE NYLOS	RING NYLOS
11	V	CUSCINETTO	BEARING	ROULEMENT	WÄZLAGER
12	V	DISTANZIALE	SPACER RING	ENTRETOISE	DISTANZSCHEIBE
13	V	SEEGER	CIRCLIP	CIRCLIP	SICHERUNGSRING
14	V	ANELLO DI TENUTA	OILSEAL	JOINT D'ETANCHEITE	ÖLDICHTRING
15	V	COPERCHIO APERTO	OPEN COVER	COUVERCLE OUVERT	DECKEL EINTRIEBSSEITE RI
16	V	GROWER	SPRING WASHER	RONDELLE FREIN	FEDERRING
17	V	VITE DI FISSAGGIO	SCREW	VIS	BEFESTIGUNGSSCHRAUBE
18	V	COPERCHIO CHIUSO	CLOSED COVER	COUVERCLE FERME'	ABSCHLUSSDECKEL SCHNECKENWELLE RMI/RI
19	V	VITE DI FISSAGGIO	SCREW	VIS	BEFESTIGUNGSSCHRAUBE
20	V	GROWER	SPRING WASHER	RONDELLE FREIN	FEDERRING
21	V	COPERCHIO APERTO	OPEN COVER	COUVERCLE OUVERT	DECKEL EINTRIEBSSEITE RI
22	V	COPERCHIO CHIUSO	CLOSED COVER	COUVERCLE FERME'	ABSCHLUSSDECKEL SCHNECKENWELLE RMI/RI
23	V	COPERCHIO IN GOMMA	RUBBER CAP	BOUCHON EN CAOUTCHOUC	GUMMIDECKEL
24	V	ALBERO LENTO "ERB"	OUTPUT SHAFT "ERB"	ARBRE PV SIMPLE "ERB"	ABTRIEBSWELLE "ERB"
25	V	LINGUETTA	KEY	CLAVETTE	PASSFEDER
26	V	ALBERO LENTO DENTATO "ERB"			
27	V	FLANGIA "FD"	FLANGE "FD"	BRIDE "FD"	FLANSCH "FD"
28	V	RONDELLA	WASHER	RONDELLE	UNTERLEGSCHNEIBE
29	V	GROWER	SPRING WASHER	RONDELLE FREIN	FEDERRING
30	V	VITE DI FISSAGGIO	SCREW	VIS	BEFESTIGUNGSSCHRAUBE
31	V	INGRASSATORE			
32	V	ALBERO LENTO "EBR"	OUTPUT SHAFT EBR	ARBRE PV SIMPLE "EBR"	ABTRIEBSWELLE "EBR"
33	V	ALBERO DENTATO "EBR"			
34	V	ALBERO LENTO BISPORGENTE "N"	DOUBLE OUTPUT SHAFT "N"	ARBRE PV DOUBLE "N"	BEIDSEITIGE ABTRIEBSWELLE "N"
35	V	LINGUETTA	KEY	CLAVETTE	PASSFEDER
36	V	ALBERO LENTO BISPORGENTE "D"	DOUBLE OUTPUT SHAFT "D"	ARBRE PV DOUBLE "D"	BEIDSEITIGE ABTRIEBSWELLE "D"
37	V	ALBERO USCITA "C"	OUTPUT SHAFT "C"	ARBRE SORTIE "C"	ABTRIEBSWELLE "C"
38	V	ALBERO USCITA "URB" "B" "UB"	OUTPUT SHAFT "URB" "B" "UB"	ARBRE SORTIE "URB" "B" "UB"	ABTRIEBSWELLE "URB" "B" "UB"
39	V	CALETTATORE	SHRINK DISC	FRETTE DE SERRAGE	SCHRUMPFSCHEIBE
40	V	ALBERO USCITA "UBR" "B" "UB"	OUTPUT SHAFT "UBR" "B" "UB"	ARBRE SORTIE "UBR" "B" "UB"	ABTRIEBSWELLE "UBR" "B" "UB"



# TAVOLA VI

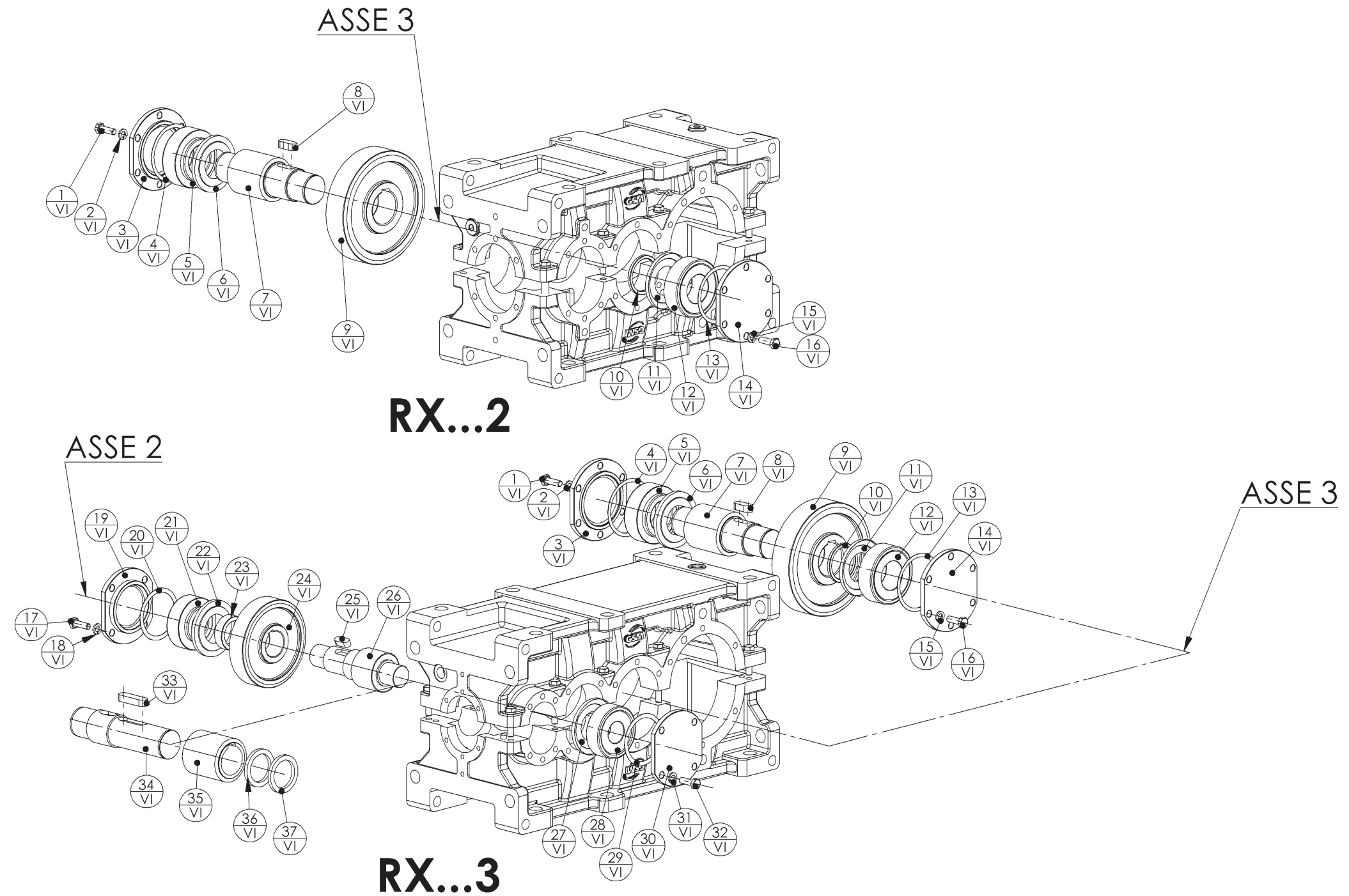

# TAVOLA VI



RXP 800

# PARTI DI RICAMBIO

## SPARE LISTS

RXP – SERIE 800

**NGQ16\_RXP**  
 Del 30/07/2012

11

 STM spa  
 VIA DEL MACCABRECCIA , 39  
 40012 - CALDERARA DI RENO (BO) ITALY  
 E-mail: [stm@stmspa.com](mailto:stm@stmspa.com)  
 TEL ++ 39.051.6467711 FAX . ++ 39.051.6466178

### TAVOLA VI

ITEM	TAVOLA	DESCRIZIONE ( I )	DESCRIPTION ( GB )	DESIGNATION ( F )	BEZEICHNUNG ( D )
1	VI	VITE DI FISSAGGIO	SCREW	VIS	BEFESTIGUNGSSCHRAUBE
2	VI	GROWER	SPRING WASHER	RONDELLE FREIN	FEDERRING
3	VI	COPERCHIO CHIUSO	CLOSED COVER	COUVERCLE FERME'	ABSCHLUSSDECKEL SCHNECKENWELLE RMI/RI
4	VI	DISTANZIALE	SPACER RING	ENTRETOISE	DISTANZSCHEIBE
5	VI	CUSCINETTO	BEARING	ROULEMENT	WÄLZLAGER
6	VI	ANELLO NYLOS	RING NYLOS	BAGUE NYLOS	RING NYLOS
7	VI	ALBERO PIGNONE	PINION SHAFT	ARBRE PIGNON	RITZELWELLE
8	VI	LINGUETTA	KEY	CLAVETTE	PASSFEDER
9	VI	CORONA CILINDRICA ELIC.	HELICAL WHEEL	ROUE CYLINDR. HELICOIDALE	ZAHNRAD (STIRNRAD)
10	VI	DISTANZIALE	SPACER RING	ENTRETOISE	DISTANZSCHEIBE
11	VI	ANELLO NYLOS	RING NYLOS	BAGUE NYLOS	RING NYLOS
12	VI	CUSCINETTO	BEARING	ROULEMENT	WÄLZLAGER
13	VI	DISTANZIALE	SPACER RING	ENTRETOISE	DISTANZSCHEIBE
14	VI	COPERCHIO CHIUSO	CLOSED COVER	COUVERCLE FERME'	ABSCHLUSSDECKEL SCHNECKENWELLE RMI/RI
15	VI	GROWER	SPRING WASHER	RONDELLE FREIN	FEDERRING
16	VI	VITE DI FISSAGGIO	SCREW	VIS	BEFESTIGUNGSSCHRAUBE
17	VI	VITE DI FISSAGGIO	SCREW	VIS	BEFESTIGUNGSSCHRAUBE
18	VI	GROWER	SPRING WASHER	RONDELLE FREIN	FEDERRING
19	VI	COPERCHIO CHIUSO	CLOSED COVER	COUVERCLE FERME'	ABSCHLUSSDECKEL SCHNECKENWELLE RMI/RI
20	VI	DISTANZIALE	SPACER RING	ENTRETOISE	DISTANZSCHEIBE
21	VI	CUSCINETTO	BEARING	ROULEMENT	WÄLZLAGER
22	VI	ANELLO NYLOS	RING NYLOS	BAGUE NYLOS	RING NYLOS
23	VI	DISTANZIALE	SPACER RING	ENTRETOISE	DISTANZSCHEIBE
24	VI	CORONA CILINDRICA ELIC.	HELICAL WHEEL	ROUE CYLINDR. HELICOIDALE	ZAHNRAD (STIRNRAD)
25	VI	LINGUETTA	KEY	CLAVETTE	PASSFEDER
26	VI	ALBERO PIGNONE	PINION SHAFT	ARBRE PIGNON	RITZELWELLE
27	VI	ANELLO NYLOS	RING NYLOS	BAGUE NYLOS	RING NYLOS
28	VI	CUSCINETTO	BEARING	ROULEMENT	WÄLZLAGER
29	VI	DISTANZIALE	SPACER RING	ENTRETOISE	DISTANZSCHEIBE
30	VI	COPERCHIO CHIUSO	CLOSED COVER	COUVERCLE FERME'	ABSCHLUSSDECKEL SCHNECKENWELLE RMI/RI
31	VI	GROWER	SPRING WASHER	RONDELLE FREIN	FEDERRING
32	VI	VITE DI FISSAGGIO	SCREW	VIS	BEFESTIGUNGSSCHRAUBE
33	VI	LINGUETTA	KEY	CLAVETTE	PASSFEDER
34	VI	ALBERO	SHAFT	ARBRE	WELLE
35	VI	PIGNONE CILINDRICO ELIC.	HELICAL PINION	PIGNON CYL. HELYCOIDAL	RITZEL (STIRNRAD)
36	VI	DISTANZIALE	SPACER RING	ENTRETOISE	DISTANZSCHEIBE
37	VI	DISTANZIALE	SPACER RING	ENTRETOISE	DISTANZSCHEIBE



## TAVOLA VII

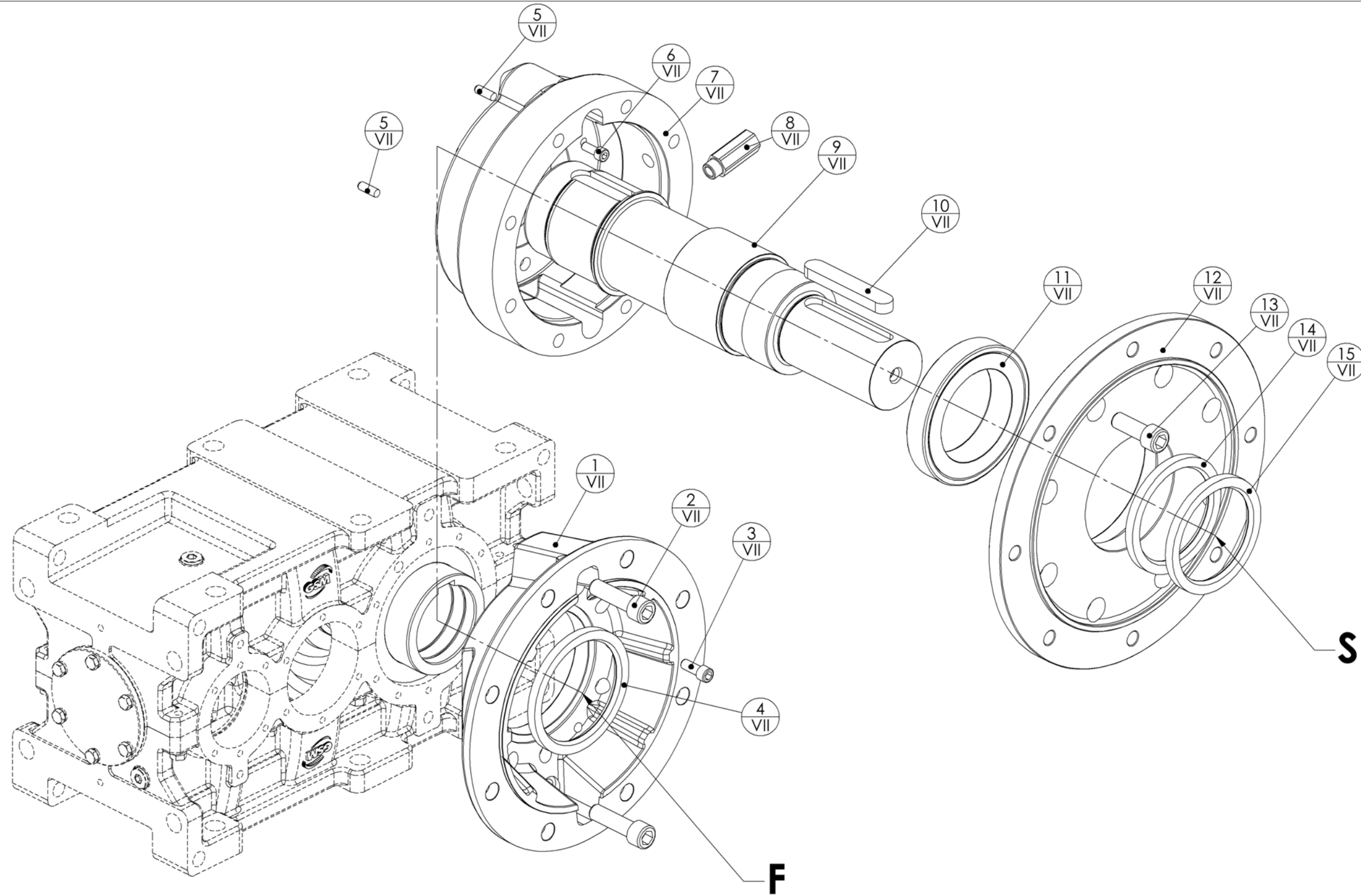

## TAVOLA VII



RXP 800

# PARTI DI RICAMBIO

## SPARE LISTS

RXP – SERIE 800

**NGQ16\_RXP**  
 Del 30/07/2012

13

 STM spa  
 VIA DEL MACCABRECCIA , 39  
 40012 - CALDERARA DI RENO (BO) ITALY  
 E-mail: [stm@stmspa.com](mailto:stm@stmspa.com)  
 TEL ++ 39.051.6467711 FAX . ++ 39.051.6466178

# TAVOLA VII

ITEM	TAVOLA	DESCRIZIONE ( I )	DESCRIPTION ( GB )	DESIGNATION ( F )	BEZEICHNUNG ( D )
1	VII	FL MODULARE F	FL MODULAR OUTPUT FLANGE F	BRIDE MODULAIRE F	ABTRIEBSFLANSCH FL MODULAR F
2	VII	VITE DI FISSAGGIO	SCREW	VIS	BEFESTIGUNGSSCHRAUBE
3	VII	VITE DI FISSAGGIO	SCREW	VIS	BEFESTIGUNGSSCHRAUBE
4	VII	ANELLO DI TENUTA	OILSEAL	JOINT D'ETANCHEITE	ÖLDICHTRING
5	VII	SPINA	PIN	GOUPILLE	STIFT
6	VII	VITE DI FISSAGGIO	SCREW	VIS	BEFESTIGUNGSSCHRAUBE
7	VII	SUPPORTO ALBERO USCITA S			
8	VII	INGRASSATORE			
9	VII	ALBERO LENTO	OUTPUT SHAFT	ARBRE PV SIMPLE	ABTRIEBSWELLE
10	VII	LINGUETTA	KEY	CLAVETTE	PASSFEDER
11	VII	CUSCINETTO	BEARING	ROULEMENT	WÄLZLAGER
12	VII	FLANGIA "S"	"S" - FLANGE	BRIDE "S"	S - DECKEL
13	VII	VITE DI FISSAGGIO	SCREW	VIS	BEFESTIGUNGSSCHRAUBE
14	VII	ANELLO DI TENUTA	OILSEAL	JOINT D'ETANCHEITE	ÖLDICHTRING
15	VII	ANELLO DI TENUTA	OILSEAL	JOINT D'ETANCHEITE	ÖLDICHTRING



**TAVOLA VIII**

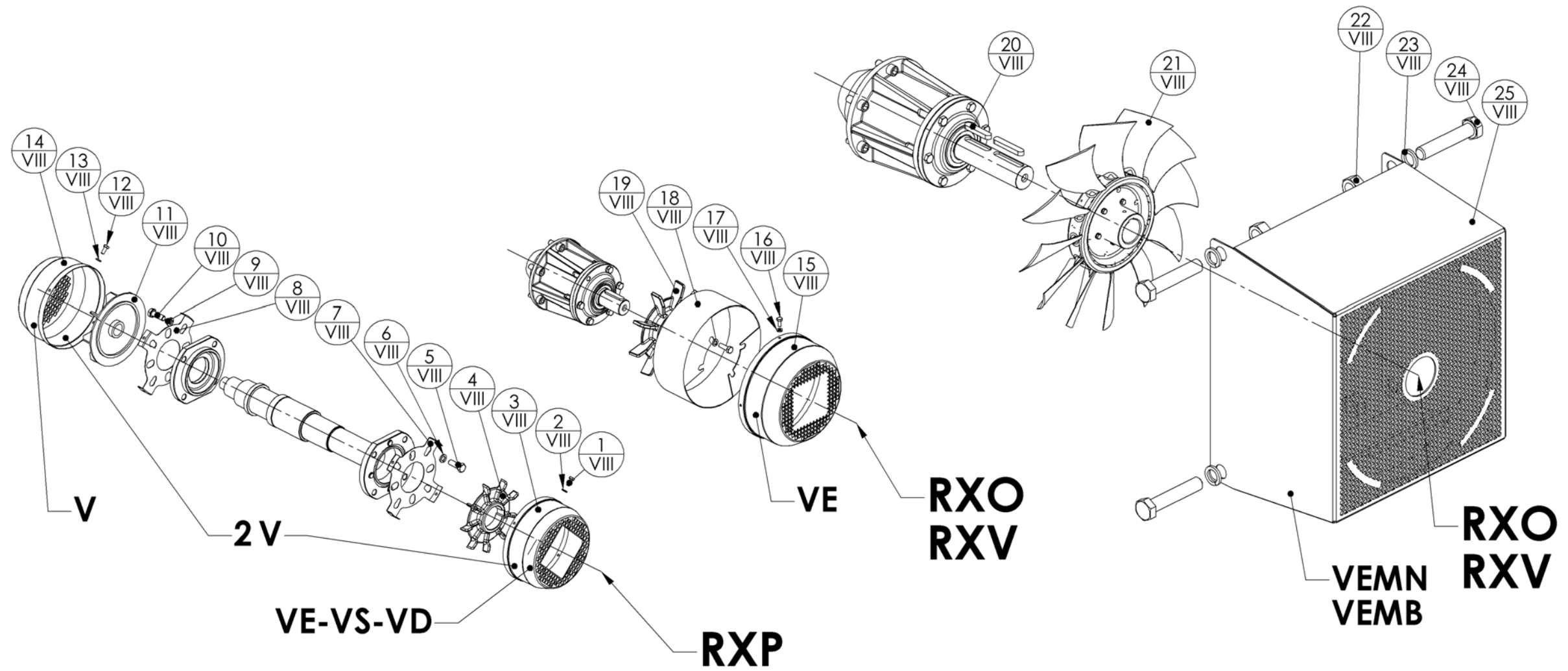

**TAVOLA VIII**



RXP 800

# PARTI DI RICAMBIO

SPARE LISTS

RXP – SERIE 800

NGQ16\_RXP

Del 30/07/2012

15

STM spa

VIA DEL MACCABRECCIA , 39  
40012 - CALDERARA DI RENO (BO) ITALY  
E-mail: [stm@stmspa.com](mailto:stm@stmspa.com)

TEL ++ 39.051.6467711 FAX . ++ 39.051.6466178

## TAVOLA VIII

ITEM	TAVOLA	DESCRIZIONE ( I )	DESCRIPTION ( GB )	DESIGNATION ( F )	BEZEICHNUNG ( D )
1	VIII	VITE DI FISSAGGIO	SCREW	VIS	BEFESTIGUNGSSCHRAUBE
2	VIII	GROWER	SPRING WASHER	RONDELLE FREIN	FEDERRING
3	VIII	COPRIVENTOLA	FAN COVER	CAPOT DE VENTILATEUR	LÜFTERHAUBE
4	VIII	VENTOLA DI RAFFREDDAMENTO	COOLING FAN	VENTILATEUR DE REFROIDISSEMENT	LÜFTER
5	VIII	VITE DI FISSAGGIO	SCREW	VIS	BEFESTIGUNGSSCHRAUBE
6	VIII	GROWER	SPRING WASHER	RONDELLE FREIN	FEDERRING
7	VIII	SUPPORTO COPRIVENTOLA	FAN COVER SUPPORT	SUPPORT CAPOT DE VENTILATEUR	AUFNAHME ABTRIEB LÜFTERHAUBE
8	VIII	SUPPORTO COPRIVENTOLA	FAN COVER SUPPORT	SUPPORT CAPOT DE VENTILATEUR	AUFNAHME ABTRIEB LÜFTERHAUBE
9	VIII	GROWER	SPRING WASHER	RONDELLE FREIN	FEDERRING
10	VIII	VITE DI FISSAGGIO	SCREW	VIS	BEFESTIGUNGSSCHRAUBE
11	VIII	VENTOLA DI RAFFREDDAMENTO	COOLING FAN	VENTILATEUR DE REFROIDISSEMENT	LÜFTER
12	VIII	VITE DI FISSAGGIO	SCREW	VIS	BEFESTIGUNGSSCHRAUBE
13	VIII	GROWER	SPRING WASHER	RONDELLE FREIN	FEDERRING
14	VIII	COPRIVENTOLA	FAN COVER	CAPOT DE VENTILATEUR	LÜFTERHAUBE
15	VIII	COPRIVENTOLA	FAN COVER	CAPOT DE VENTILATEUR	LÜFTERHAUBE
16	VIII	VITE DI FISSAGGIO	SCREW	VIS	BEFESTIGUNGSSCHRAUBE
17	VIII	GROWER	SPRING WASHER	RONDELLE FREIN	FEDERRING
18	VIII	SUPPORTO VENTOLA			
19	VIII	VENTOLA DI RAFFREDDAMENTO	COOLING FAN	VENTILATEUR DE REFROIDISSEMENT	LÜFTER
20	VIII	LINGUETTA	KEY	CLAVETTE	PASSFEDER
21	VIII	VENTOLA DI RAFFREDDAMENTO	COOLING FAN	VENTILATEUR DE REFROIDISSEMENT	LÜFTER
22	VIII	DADO	NUT	ECROU	MUTTER
23	VIII	GROWER	SPRING WASHER	RONDELLE FREIN	FEDERRING
24	VIII	VITE DI FISSAGGIO	SCREW	VIS	BEFESTIGUNGSSCHRAUBE
25	VIII	COPRIVENTOLA	FAN COVER	CAPOT DE VENTILATEUR	LÜFTERHAUBE



## TAVOLA IX

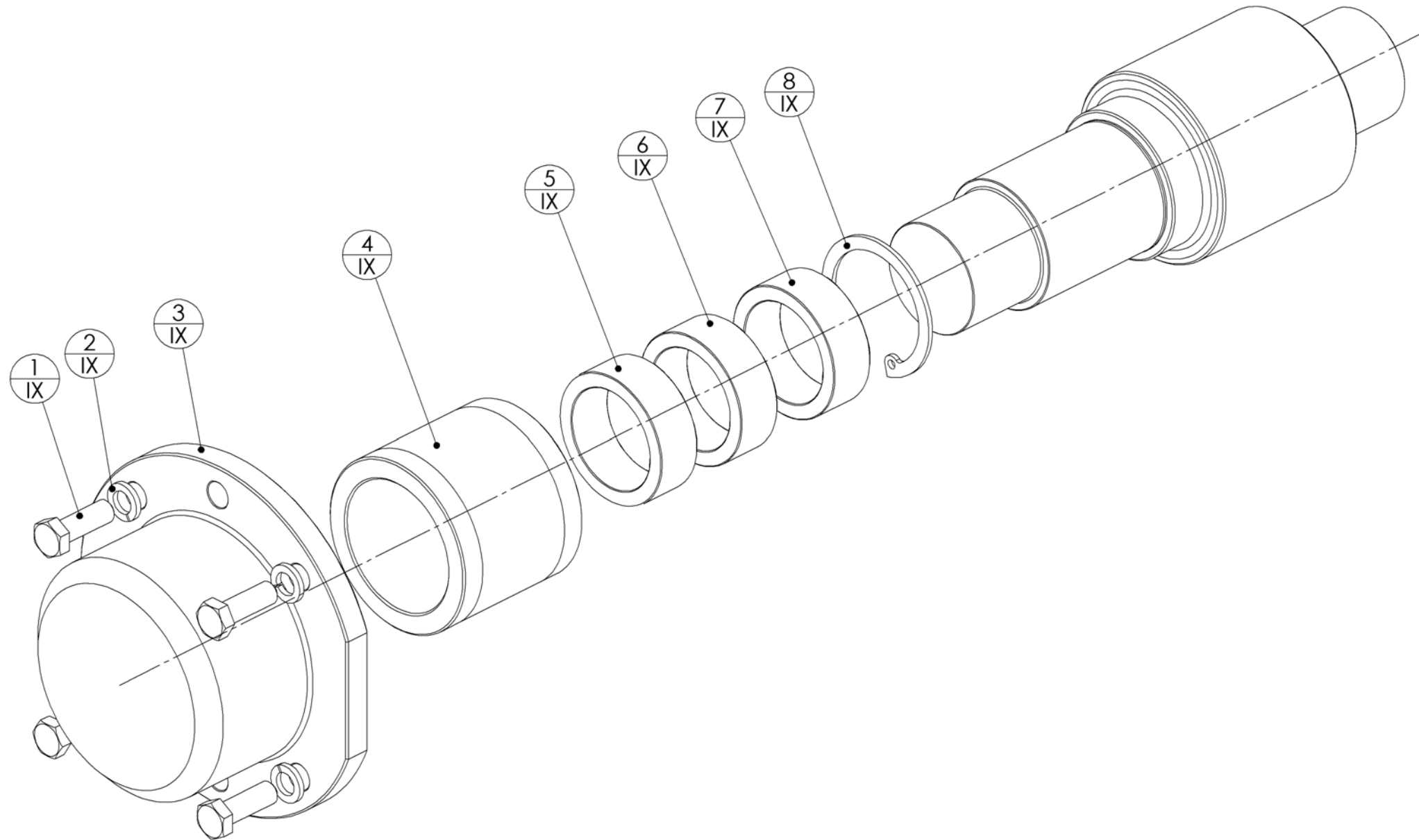

## TAVOLA IX





RXP 800

# PARTI DI RICAMBIO SPARE LISTS

RXP – SERIE 800

NGQ16\_RXP  
Del 30/07/2012

17

STM spa  
VIA DEL MACCABRECCIA , 39  
40012 - CALDERARA DI RENO (BO) ITALY  
E-mail: [stm@stmspa.com](mailto:stm@stmspa.com)  
TEL ++ 39.051.6467711 FAX . ++ 39.051.6466178

## TAVOLA IX

ITEM	TAVOLA	DESCRIZIONE ( I )	DESCRIPTION ( GB )	DESIGNATION ( F )	BEZEICHNUNG ( D )
1	IX	VITE DI FISSAGGIO	SCREW	VIS	BEFESTIGUNGSSCHRAUBE
2	IX	GROWER	SPRING WASHER	RONDELLE FREIN	FEDERRING
3	IX	COPERCHIO CHIUSO	CLOSED COVER	COUVERCLE FERME'	ABSCHLUSSDECKEL SCHNECKENWELLE RMI/RI
4	IX	BUSSOLA			
5	IX	CUSCINETTO ANTIRETRO	BACKSTOP BEARING	ROULEMENT ANTIDEVIREUR	WÄLZLAGER MIT RÜCKLAUFSPERRE
6	IX	CUSCINETTO ANTIRETRO	BACKSTOP BEARING	ROULEMENT ANTIDEVIREUR	WÄLZLAGER MIT RÜCKLAUFSPERRE
7	IX	CUSCINETTO ANTIRETRO	BACKSTOP BEARING	ROULEMENT ANTIDEVIREUR	WÄLZLAGER MIT RÜCKLAUFSPERRE
8	IX	SEEGER	CIRCLIP	CIRCLIP	SICHERUNGSRING



# TAVOLA X

## TAVOLA X

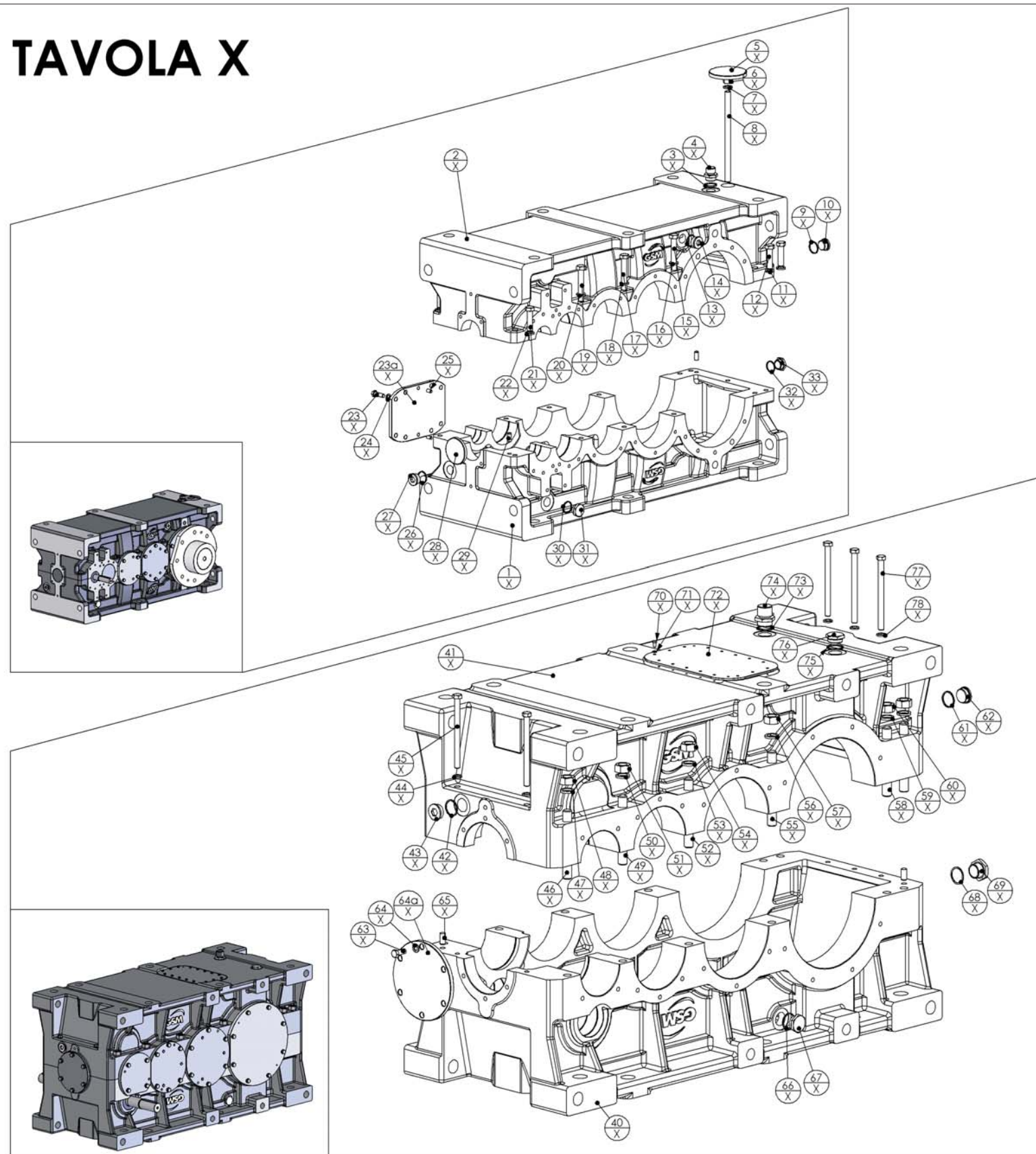



RXP 800

# PARTI DI RICAMBIO

## SPARE LISTS

RXP – SERIE 800

NGQ16\_RXP  
Del 30/07/2012

19

STM spa  
VIA DEL MACCABRECCIA, 39  
40012 - CALDERARA DI RENO (BO) ITALY  
E-mail: [stm@stmspa.com](mailto:stm@stmspa.com)  
TEL ++ 39.051.6467711 FAX . ++ 39.051.6466178

### TAVOLA X

ITEM	TAVOLA	DESCRIZIONE ( I )	DESCRIPTION ( GB )	DESIGNATION ( F )	BEZEICHNUNG ( D )
1	X	CASSA			
2	X	COPERCHIO	COVER	COUVERCLE	DECKEL
3	X	GUARNIZIONE	GASKET	JOINT PAPIER	DICHTUNG
4	X	TAPPO	PLUG	BOUCHON	VERSCHLUSS
5	X	TAPPO RCA	PLUG RCA	BOUCHON RCA	VERSCHLUSS RCA
6	X	DADO	NUT	ECROU	MUTTER
7	X	GROWER	SPRING WASHER	RONDELLE FREIN	FEDERRING
8	X	PRIGIONIERO	STUD	PRISONNIER	STIFTSCHRAUBE
9	X	GUARNIZIONE	GASKET	JOINT PAPIER	DICHTUNG
10	X	TAPPO	PLUG	BOUCHON	VERSCHLUSS
11	X	GROWER	SPRING WASHER	RONDELLE FREIN	FEDERRING
12	X	VITE DI FISSAGGIO	SCREW	VIS	BEFESTIGUNGSSCHRAUBE
13	X	GUARNIZIONE	GASKET	JOINT PAPIER	DICHTUNG
14	X	TAPPO	PLUG	BOUCHON	VERSCHLUSS
15	X	VITE DI FISSAGGIO	SCREW	VIS	BEFESTIGUNGSSCHRAUBE
16	X	GROWER	SPRING WASHER	RONDELLE FREIN	FEDERRING
17	X	VITE DI FISSAGGIO	SCREW	VIS	BEFESTIGUNGSSCHRAUBE
18	X	GROWER	SPRING WASHER	RONDELLE FREIN	FEDERRING
19	X	VITE DI FISSAGGIO	SCREW	VIS	BEFESTIGUNGSSCHRAUBE
20	X	GROWER	SPRING WASHER	RONDELLE FREIN	FEDERRING
21	X	VITE DI FISSAGGIO	SCREW	VIS	BEFESTIGUNGSSCHRAUBE
22	X	GROWER	SPRING WASHER	RONDELLE FREIN	FEDERRING
23	X	VITE DI FISSAGGIO	SCREW	VIS	BEFESTIGUNGSSCHRAUBE
23a	X	COPERCHIO CHIUSO	CLOSED COVER	COUVERCLE FERME'	ABSCHLUSSDECKEL SCHNECKENWELLE RMI/RI
24	X	GROWER	SPRING WASHER	RONDELLE FREIN	FEDERRING
25	X	SPINA	PIN	GOUPILLE	STIFT
26	X	GUARNIZIONE	GASKET	JOINT PAPIER	DICHTUNG
27	X	TAPPO	PLUG	BOUCHON	VERSCHLUSS
28	X	TAPPO RCA	PLUG RCA	BOUCHON RCA	VERSCHLUSS RCA
29	X	SPINA	PIN	GOUPILLE	STIFT
30	X	GUARNIZIONE	GASKET	JOINT PAPIER	DICHTUNG
31	X	TAPPO	PLUG	BOUCHON	VERSCHLUSS
32	X	GUARNIZIONE	GASKET	JOINT PAPIER	DICHTUNG
33	X	TAPPO	PLUG	BOUCHON	VERSCHLUSS
34	X				
35	X				
36	X				
37	X				
38	X				
39	X				
40	X	CASSA			
41	X	COPERCHIO	COVER	COUVERCLE	DECKEL
42	X	GUARNIZIONE	GASKET	JOINT PAPIER	DICHTUNG
43	X	TAPPO	PLUG	BOUCHON	VERSCHLUSS
44	X	GROWER	SPRING WASHER	RONDELLE FREIN	FEDERRING
45	X	VITE DI FISSAGGIO	SCREW	VIS	BEFESTIGUNGSSCHRAUBE
46	X	PRIGIONIERO	STUD	PRISONNIER	STIFTSCHRAUBE



RXP 800

# PARTI DI RICAMBIO

## SPARE LISTS

RXP – SERIE 800

NGQ16\_RXP

Del 30/07/2012

20

STM spa

VIA DEL MACCABRECCIA , 39  
40012 - CALDERARA DI RENO (BO) ITALY  
E-mail: [stm@stmspa.com](mailto:stm@stmspa.com)

TEL ++ 39.051.6467711 FAX . ++ 39.051.6466178

# TAVOLA X

ITEM	TAVOLA	DESCRIZIONE ( I )	DESCRIPTION ( GB )	DESIGNATION ( F )	BEZEICHNUNG ( D )
47	X	GROWER	SPRING WASHER	RONDELLE FREIN	FEDERRING
48	X	DADO	NUT	ECROU	MUTTER
49	X	PRIGIONIERO	STUD	PRISONNIER	STIFTSCHRAUBE
50	X	GROWER	SPRING WASHER	RONDELLE FREIN	FEDERRING
51	X	DADO	NUT	ECROU	MUTTER
52	X	PRIGIONIERO	STUD	PRISONNIER	STIFTSCHRAUBE
53	X	GROWER	SPRING WASHER	RONDELLE FREIN	FEDERRING
54	X	DADO	NUT	ECROU	MUTTER
55	X	PRIGIONIERO	STUD	PRISONNIER	STIFTSCHRAUBE
56	X	GROWER	SPRING WASHER	RONDELLE FREIN	FEDERRING
57	X	DADO	NUT	ECROU	MUTTER
58	X	PRIGIONIERO	STUD	PRISONNIER	STIFTSCHRAUBE
59	X	GROWER	SPRING WASHER	RONDELLE FREIN	FEDERRING
60	X	DADO	NUT	ECROU	MUTTER
61	X	GUARNIZIONE	GASKET	JOINT PAPIER	DICHTUNG
62	X	TAPPO	PLUG	BOUCHON	VERSCHLUSS
63	X	VITE DI FISSAGGIO	SCREW	VIS	BEFESTIGUNGSSCHRAUBE
64	X	GROWER	SPRING WASHER	RONDELLE FREIN	FEDERRING
64a	X	COPERCHIO CHIUSO	CLOSED COVER	COUVERCLE FERME'	ABSCHLUSSDECKEL SCHNECKENWELLE RMI/RI
65	X	SPINA	PIN	GOUPILLE	STIFT
66	X	GUARNIZIONE	GASKET	JOINT PAPIER	DICHTUNG
67	X	TAPPO	PLUG	BOUCHON	VERSCHLUSS
68	X	GUARNIZIONE	GASKET	JOINT PAPIER	DICHTUNG
69	X	TAPPO	PLUG	BOUCHON	VERSCHLUSS
70	X	VITE DI FISSAGGIO	SCREW	VIS	BEFESTIGUNGSSCHRAUBE
71	X	GROWER	SPRING WASHER	RONDELLE FREIN	FEDERRING
72	X	COPERCHIO CHIUSO	CLOSED COVER	COUVERCLE FERME'	ABSCHLUSSDECKEL SCHNECKENWELLE RMI/RI
73	X	GUARNIZIONE	GASKET	JOINT PAPIER	DICHTUNG
74	X	TAPPO	PLUG	BOUCHON	VERSCHLUSS
75	X	GUARNIZIONE	GASKET	JOINT PAPIER	DICHTUNG
76	X	TAPPO	PLUG	BOUCHON	VERSCHLUSS
77	X	VITE DI FISSAGGIO	SCREW	VIS	BEFESTIGUNGSSCHRAUBE
78	X	GROWER	SPRING WASHER	RONDELLE FREIN	FEDERRING



# TAVOLA XI

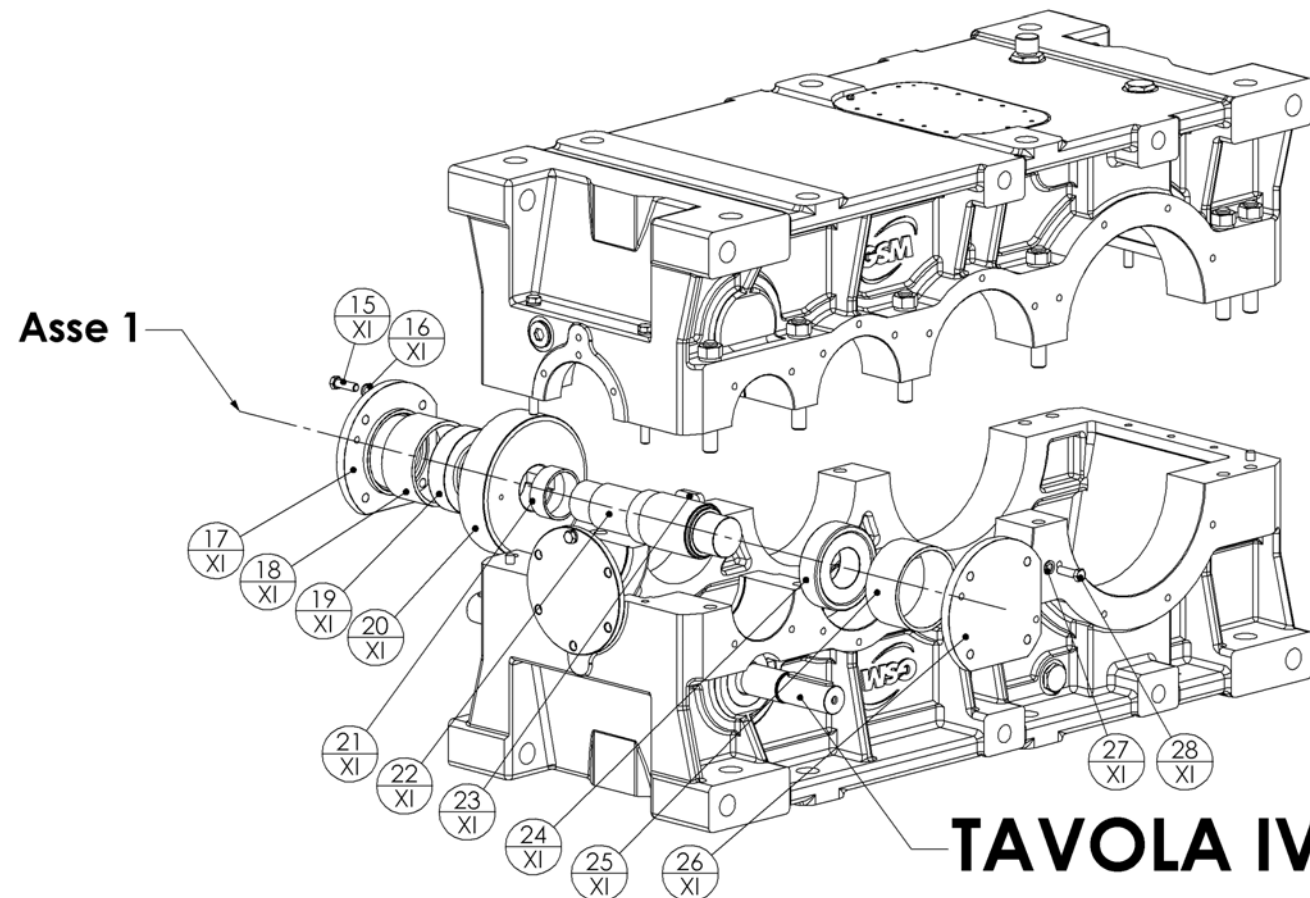
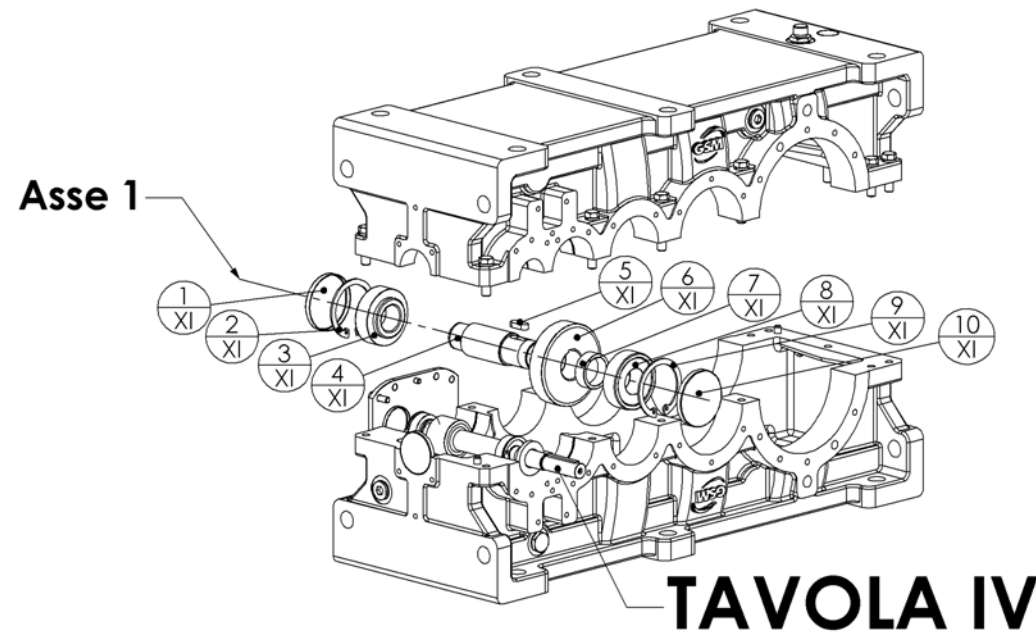

# TAVOLA XI



RXP 800

# PARTI DI RICAMBIO

## SPARE LISTS

RXP – SERIE 800

**NGQ16\_RXP**  
 Del 30/07/2012
**22**
 STM spa  
 VIA DEL MACCABRECCIA , 39  
 40012 - CALDERARA DI RENO (BO) ITALY  
 E-mail: [stm@stmspa.com](mailto:stm@stmspa.com)  
 TEL ++ 39.051.6467711 FAX . ++ 39.051.6466178

# TAVOLA XI

ITEM	TAVOLA	DESCRIZIONE ( I )	DESCRIPTION ( GB )	DESIGNATION ( F )	BEZEICHNUNG ( D )
1	XI	TAPPO RCA	PLUG RCA	BOUCHON RCA	VERSCHLUSS RCA
2	XI	SEEGER	CIRCLIP	CIRCLIP	SICHERUNGSRING
3	XI	CUSCINETTO	BEARING	ROULEMENT	WÄLZLAGER
4	XI	ALBERO PIGNONE	PINION SHAFT	ARBRE PIGNON	RITZELWELLE
5	XI	LINGUETTA	KEY	CLAVETTE	PASSFEDER
6	XI	CORONA CILINDRICA ELIC.	HELICAL WHEEL	ROUE CYLINDR. HELICOIDALE	ZAHNRAD (STIRNRAD)
7	XI	DISTANZIALE	SPACER RING	ENTRETOISE	DISTANZSCHEIBE
8	XI	CUSCINETTO	BEARING	ROULEMENT	WÄLZLAGER
9	XI	SEEGER	CIRCLIP	CIRCLIP	SICHERUNGSRING
10	XI	TAPPO RCA	PLUG RCA	BOUCHON RCA	VERSCHLUSS RCA
11	XI				
12	XI				
13	XI				
14	XI				
15	XI	VITE DI FISSAGGIO	SCREW	VIS	BEFESTIGUNGSSCHRAUBE
16	XI	GROWER	SPRING WASHER	RONDELLE FREIN	FEDERRING
17	XI	COPERCHIO CHIUSO	CLOSED COVER	COUVERCLE FERME'	ABSCHLUSSDECKEL SCHNECKENWELLE RMI/RI
18	XI	DISTANZIALE	SPACER RING	ENTRETOISE	DISTANZSCHEIBE
19	XI	CUSCINETTO	BEARING	ROULEMENT	WÄLZLAGER
20	XI	CORONA CILINDRICA ELIC.	HELICAL WHEEL	ROUE CYLINDR. HELICOIDALE	ZAHNRAD (STIRNRAD)
21	XI	DISTANZIALE	SPACER RING	ENTRETOISE	DISTANZSCHEIBE
22	XI	ALBERO PIGNONE	PINION SHAFT	ARBRE PIGNON	RITZELWELLE
23	XI	LINGUETTA	KEY	CLAVETTE	PASSFEDER
24	XI	CUSCINETTO	BEARING	ROULEMENT	WÄLZLAGER
25	XI	DISTANZIALE	SPACER RING	ENTRETOISE	DISTANZSCHEIBE
26	XI	COPERCHIO CHIUSO	CLOSED COVER	COUVERCLE FERME'	ABSCHLUSSDECKEL SCHNECKENWELLE RMI/RI
27	XI	GROWER	SPRING WASHER	RONDELLE FREIN	FEDERRING
28	XI	VITE DI FISSAGGIO	SCREW	VIS	BEFESTIGUNGSSCHRAUBE