

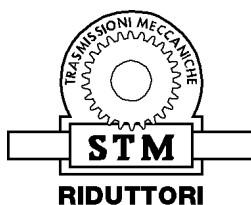

**ELECTRONIC SPEED VARIATOR**

***New Intelligent Systems***

**ESV User Manual**  
**CAPACITORLESS**  
**VECTOR**



S.T.M. S.p.A.

Via del Maccabreccia, 39 – I 40012 Lippo di Calderara di Reno (BO)

T: 051/37.65.711 – F: 051/64.26.178

URL: [www.stmspa.com](http://www.stmspa.com) - E-MAIL: [stm@stmspa.com](mailto:stm@stmspa.com) / [service@stmspa.com](mailto:service@stmspa.com)

## Summary

1. GENERAL INFORMATION.....	4
1.1 Manufacturer and machine data .....	4
1.2 Designation.....	5
1.3 Guarantee and service conditions .....	5
1.4 Used symbology .....	5
1.5 Safety global aspects .....	6
1.6 Responsibilities.....	6
2. MACHINE DESCRIPTION AND TECHNICAL DATA .....	7
2.1 General description.....	7
2.1.1 Model with cooling forced (Cooling forced=VFT o VF) .....	7
2.1.2 self-cooled model (option Ventilation=AV).....	8
2.3 THREE PHASE DATA SHEET .....	9
3. TRANSPORT, HANDLING, STORING .....	9
3.1 Warnings.....	9
3.2 Indication and methods of transport, handling storing. ....	9
3.3 Deposit and storing .....	10
4. INSTALLATION .....	10
4.1 Warnings.....	10
4.2 Environmental using conditions .....	10
4.3 Necessary place during the functioning.....	11
4.4 Placing and installation on the spot .....	11
4.5 Connection to electric line.....	11
4.6 Installation .....	13
5. MACCHINE USE .....	14
5.1 Warnings.....	14
5.2 Safety systems .....	14
5.3 Control, regulation and signalling systems.....	14
5.3.1 Start up and stop .....	15
5.3.2 Speed rotation regulation.....	16
5.3.3 Ramp regulation acceleration .....	16
5.3.4 Motion enabling.....	16
5.3.5 Selection of the direction .....	16
5.3.6 Wiring braking resistance.....	16
5.4 Terminal connections .....	17
5.4.1 power terminal.....	17
5.4.2 command terminal .....	20
5.4.2.2 Membrane keypad (only for I/O=M).....	22
5.4.1 Electrical wiring and connections.....	23
6. DIAGNOSTIC AND INTERVENTION.....	24

6.1 Diagnostic LED .....	25
6.2 Error List .....	26
7. MANTEINANCE.....	28
7.1 Warnings.....	28
7.2 Cleaning and ordinary maintenance .....	28
7.3 Periodical inspection .....	29
7.4 Replace the bearings and other parts .....	29
8. PLACING OUT OF SERVICE .....	29
9. CONFIGURATION PARAMETERS.....	30
9.1 USER Menù.....	30
9.2 Parameter description .....	30
9.2.1 Basic parameters.....	31
9.2.2 Preset speed mode .....	36
9.2.3 Motorised potentiometer.....	37
9.2.4 PID process controller .....	38
9.2.5 Analogue inputs.....	40
9.2.7 Analogue output .....	42
9.2.8 Digital outputs .....	43
9.2.9 Relay.....	44
9.2.10 External fault .....	45
9.2.11 Motor current limit .....	46
9.2.12 Stall detection .....	47
9.3 Performance parameters .....	48
9.3.1 Motor data .....	48
9.3.2 I <sup>2</sup> T control.....	50
9.3.3 Switching frequency .....	50
9.3.4 Controller data .....	51
9.3.5 Quadratic characteristic .....	52
9.3.7 Field bus .....	54
9.3.7 MODBUS parameters.....	55
10 Accessories .....	56
10.1 ESV TST MMI.....	56
10.2 INTERFACE CABLE PC USB – MMI.....	56
10.3 Cable and connector for PROFIBUS communication.....	57

# 1. GENERAL INFORMATION

## 1.1 Manufacturer and machine data

Manufacturer: S.T.M. Spa - Via del Maccabreccia, 39  
 I 40012 Lippo di Calderara di Reno – (BO)  
 T: +39/051/37.65.711 – F: +39/051/64.26.178  
 URL: [www.stmspa.com](http://www.stmspa.com)  
 E-MAIL: [stm@stmspa.com](mailto:stm@stmspa.com) / [service@stmspa.com](mailto:service@stmspa.com)

Model and serial number : model, serial number and main characteristics of the device are placed on the product identification plate, on the top of the cover of the control box (fig. 1.3). In fig. 1.1 it is showed the place of the electric motor, while in fig. 1.2 it is showed a representation of the plate itself and of the different descriptive fields .

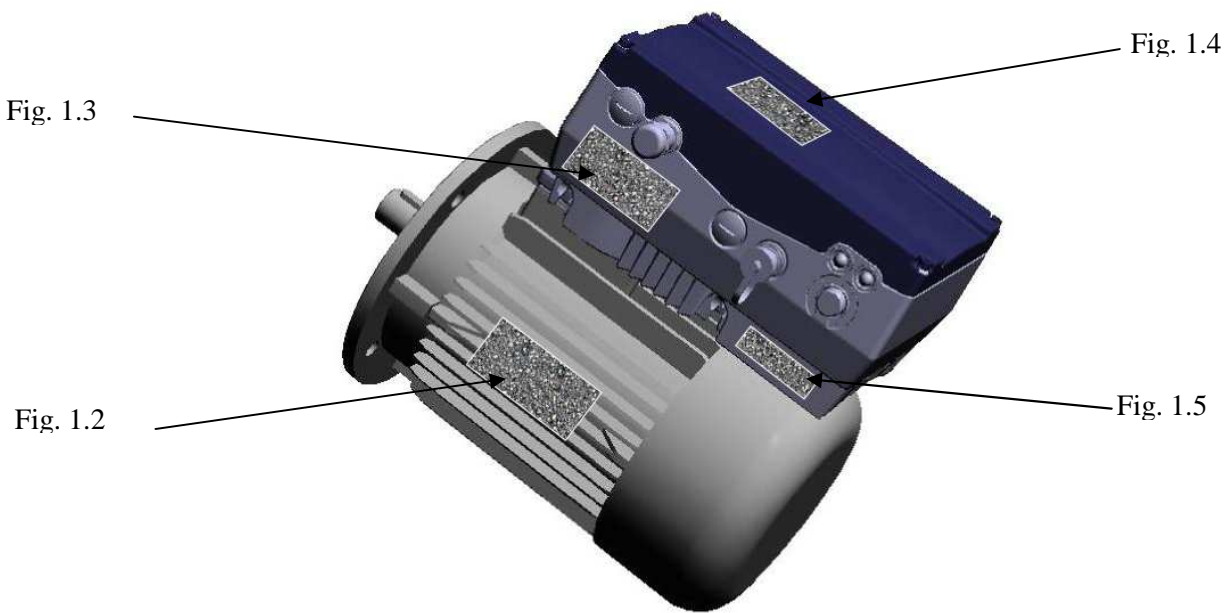

Fig. 1.1

STM BOLOGNA - ITALY		CE	
~ Mot 71B4-S		No 00430113 IP55 IC F	
Serv S1	Cos. 0,84	IP	
V Δ/Y	Hz	hp	kW rpm A Δ/Y
230/400	50	0,50	0,37 1370 1,7/1,0
240/415	50	0,50	0,37 1370 1,8/1,1
260/440	60	0,6	0,44 1640 1,8/1,1
280/480	60	0,60	0,44 1640 1,7/1,0
MOTORE ASINCRONO			

VELA STM S.p.a		CE	
ELECTRIC MOTORS		Is. CL F	IP 55 S1 Cos φ 0.78
VL2 802-4		NO. R. 131005204	
V Δ/λ	Hz	Hp	kW RPM A Δ/λ
230/400	50	1	0.75 1380 3.35/1.93
277/480	60	1.2	0.9 1656 3.35/1.93
IMPORTATO DA STM BO-ITALIA AMBIENT TEMP.: 45 C°			

Fig. 1.1 motor plate

ESV		STM RIDUTTORI	
ELECTRONIC SPEED VARIATOR			
BOLOGNA - ITALY - <a href="http://www.stmspa.com">www.stmspa.com</a>			
TEL. ++39 0513765711			
CODE 2502770031			
TYPE ESV 05 C4TS 7124B5AV			
SUPPLY 400 V	DATE 09/14		
50/60 Hz	S/N 124.2014.A		

Fig. 1.2 ESV label



Fig. 1.3 safety label

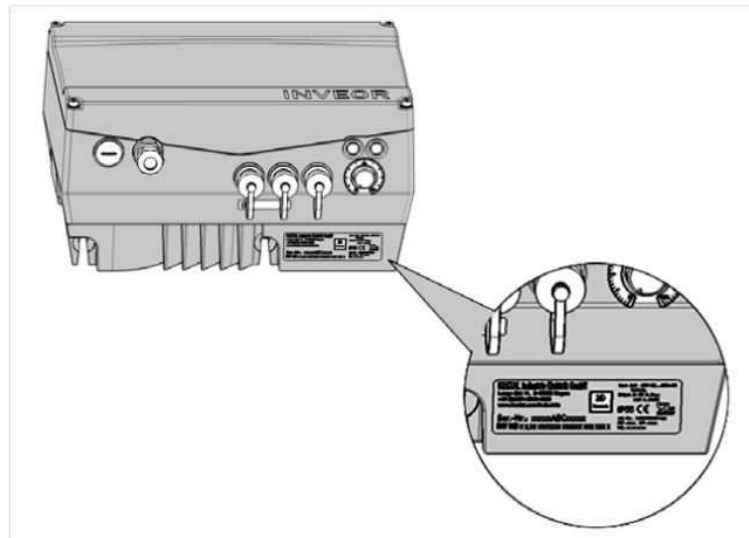

Fig. 1.4 motor drive (inverter)

## 1.2 Designation

Is made with catalogue .Check between catalogue and this manual for correct function product.

## 1.3 Guarantee and service conditions

The guarantee for the construction faults is one year from the items invoice date.





The guarantee conditions and modalities to refer to are the ones indicated on the backside of the transport document.

If authorised service is required please ask the supplier.

## 1.4 Used symbology

Hereafter follows the list of the conventional symbols used in the present manual with relative explanation.

SYMBOL	DESCRIPTION
	<p><b>GENERAL DANGER</b></p> <p>It signals to the personnel that the described operations could cause accident, if not made in the respect of the indicated safety norms.</p>

	<b>ELECTROCUTION DANGER</b> It signals the interested personnel that the described operation could cause electric shock or other electric damages if not made in the respect of the indicated safety norms.
	<b>FIRE DANGER</b> It signals the interested personnel that the described operation or circumstance could cause fires.
	<b>PERSONAL PROTECTION</b> This symbol requires the use of personal protections to the operator while making the described operations.
	<b>N.B.</b> It signals to the interested personnel important information about the management of the machine.

## 1.5 Safety global aspects

 This manual contains important information to avoid that incorrect use of ESV causes danger to people or things. Carefully follow the instructions during the installation and use phase of the device.

	<p>Before installing ESV check to have received the right model by carefully reading the information on the device plate; see description at point 1.1. If a wrong model was delivered, immediately contact the supplier.</p> <p>The ESV presented in this manual is an electric motor with a variable speed, to be used on a machinery and supplied by electric line.</p> <p>The above machineries could be dangerous for the users/operators, both as for the electric supply and for the handling of electrical organs. Consequently, before starting the machinery described in this manual (hereinafter called «ESV») it is compulsory to carefully follow instructions in this manual.</p> <p>ESV installation and use must be made by qualified personnel for mechanical and electrical operations on the machinery.</p> <p>Immediately inform the supplier of eventual damages during the transport: in this case do not start it.</p> <p><b>Keep these instructions in a safe place, available in every moment.</b></p>
---	--

	All adjustment operations of internal parameters which provide for the access to the control box must be made with no supply of electric energy and after having waited at least five minutes from all phases disconnection before removing the cover from the control box.
---	---

	<p>No modification of any kind must be made to the machinery</p> <p>The components of the machinery (motor, control box, electronic cards, etc.) mustn't be disassembled</p> <p>Do not put any kind of object inside the control box</p> <p>Inside the system there are no repairable or upkeepable parts from the user. In case of breakdown switch the machine of the supply and contact the authorised service</p>
---	---

## 1.6 Responsibilities

S.T.M. Spa undertakes no responsibility for consequences and damages caused by the non-respect of what expressed in the present manual.

It is user's competence and responsibility to evaluate the risks and find out the adequate safety norms of the system on which ESV is installed .

This technical documentation cancels and substitutes each previous edition and revision. We reserve the right to modify the above mentioned documentation everytime it will be necessary.

If you do not receive this document by means of a controlled distribution, its updating won't be assured. In order to verify whether this is the last version, do not hexitate to contact STM Sales Dept.

## 2. MACHINE DESCRIPTION AND TECHNICAL DATA

### 2.1 General description

Figure 2.1 shows a schematic representation of ESV and its main parts.



Fig. 2.1

The electronic speed variator is given by an electric motor which is controlled by an electronic circuit.

The control keyboard allows the user to easily and quickly enter any parameter necessary for the required working conditions.

The threephase, variable frequency, alternate voltage, controlled by microprocessor, is delivered to the motor through a power module which uses the most recent IGBT technology.

The software, properly developed for power electronics, allows for an accurate and quick control of motor speed, start and stop times which can be independently adjusted, and other operation conditions:

- The speed control function of the load by adjustment of the current which allows the automatic adjustment process.
- The automatic boost that allows a secure start acting on the torque as a function of the load. The presence of high torque loading and uniformity of rotation even at very low speeds
- The DC braking, programmable as durability and value, providing a safe stopping.
- The presence of a serial line (or other field bus) is used to program and / or remote control of the electronic speed control

#### 2.1.1 Model with cooling forced (Cooling forced=VFT o VF)

The main features of ESV programmed factory, with regard to the normal operation in continuous, are:

- Variable speed motor from 3 Hz to fb (frequanza basis) of the motor (for a model to be 4-pole 100 rpm to 1500 rpm)
- The profile of the rated torque and maximum output is constant is shown in fig.2.2.

Between 0 and 3 Hz the rated torque of the motor is not guaranteed

Between 3 Hz and the frequency  $f_b$  ESV operates at constant torque

In addition to frequency  $f_b$  ESV working at constant power

- ESV is equipped with a series of electronic protections that allow temporarily to exceed the limits of the nominal operation during continuous work.

In particular: it is acceptable to place the working point between 100% and 150% of the rated torque, provided that the required power is less than the nominal, as beyond a certain time the system can go into overtemperature alarm and lock.

- If the required torque requires a current greater than 150% of rated current occurs immediately stop ESV.

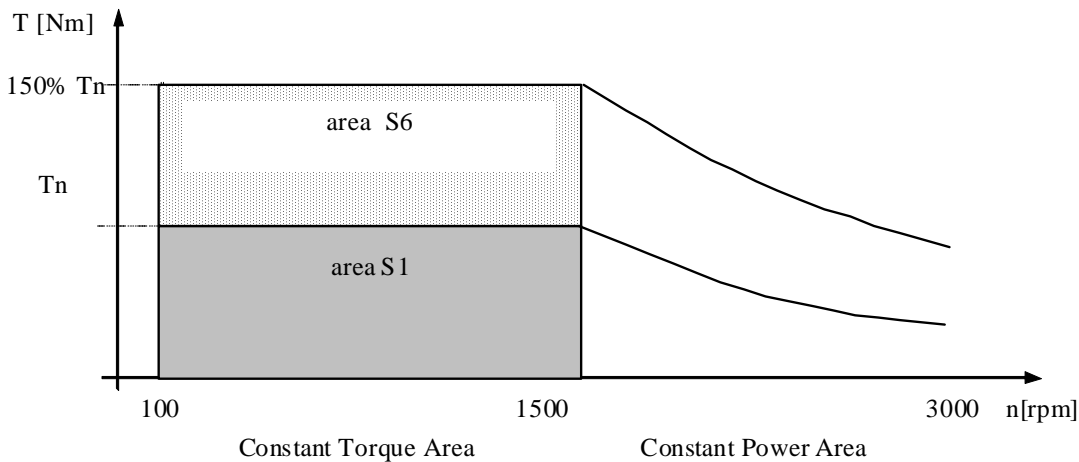

In Fig. 2.2 it is showed the mechanical characteristic, with indications of the working areas admissible in a continuous or discontinuous way. The curve are referred to 4 poles motor.

T [Nm] torque

$T_n$  [Nm] nominal torque (rated)

$T_s$  [Nm] distributable torque in continuous service (S1)

$T_{max}$  [Nm] maximum torque supplied with the 150% of nominal current applied to the electric motor



Please note the system will block immediately: the electronic control let the shaft free to turn and it is necessary to check the effects.

**ATTENTION : the ESV is not a safety device.**

### 2.1.2 self-cooled model (option Ventilation=AV)

The standard version is self-cooled so it is necessary to verify thermal according to the working conditions that sometimes require the installation of an external fan for optimal functioning.

The continuous duty S1 can be used with torque approximately in proportion to the speed



## 2.3 THREE PHASE DATA SHEET

ESV	05 4T	10 4T	15 4T	20 4T	30 4T	40 4T	50 4T	75 4T	100 4T	150 4T	200 4T	250 4T	300 4T
Pn[kW]	0,37	0,75	1,1	1,5	2,2	3	4	5,5	7,5	11	15	18,5	22
Tn[Nm]	2,5	5,0	7,4	10,0	14,7	20	27	37	49	74	98	121	143
Ts	From zero to nominal torque												
Ts	0 - Tn												
Te	0 - 150% Tn												0- 130%Tn
Tmax	150% Tn												0- 130%Tn
N	100 – 1500 rpm												
T [°C]	0° - 40°												
V.line	400 V – 15 % / 460V+10% - 47/63 Hz												
EMC	Integrate DIN EN 61800-3 class C2												
IP	IP55 Standard (IP65 a richiesta)										IP55		

Pn	[KW]	nominal power
Tn	[Nm]	nominal torque
Ts	[Nm]	deliverable torque in continuous service (S1)
Te	[Nm]	deliverable torque overload condition (S6)
Tmax	[Nm]	maximum torque
N	[min <sup>-1</sup> ]	[rpm] speed
T	[°C]	temperature
In	[A]	nominal current
EMC		line filter EMC
IP		protection of equipment respect to solid and liquid

## 3. TRANSPORT, HANDLING, STORING

### 3.1 Warnings



The transport and handling of the product both packed and unpacked can be risky for the operator for the machine weight (see paragraph 2.2.1) and its mechanical characteristics.

### 3.2 Indication and methods of transport, handling storing.

Transport product only if properly packed and protected from bumps, dust and dirt.



Before moving or packaging the machine, control box cover is correctly closed and screwed and can grant a good mechanical protection to the inner electronic card.



The handling of non-packaged product, both manual and with handling systems, mustn't be made using as lifting point the control box or the metallic protection of the back cooling fan. Use only the frame or the attack flange of the motor.  
The risks in ESV lifting and moving must be afforded by the user in relation to the different situations. If ESV weight more than 30kg , it is necessary to use an adequate lifting device.

### 3.3 Deposit and storing

To deposit and store the packed product please follow the above specifications.

ESV	05 4T	10 4T	15 4T	20 4T	30 4T	40 4T	50 4T	75 4T	100 4T	150 4T	200 4T	250 4T	300 4T
Pn[kW]	0,37	0,75	1,1	1,5	2,2	3	4	5,5	7,5	11	15	18,5	22
Maximum number of stackable packaging	2												
Deposit environmental conditions	Temperature: from -10 to +80 °C Relative humidity: less than 90%, without moisture Lack of dust and vibrations												
Weight of product [kg] (model=AV and 4 poles)	10,2	14,9	18,4	22,1	27,6	30,6	39,1	52,7	62,9	143	167	212	235

Peso [kg] Servoventilazione	56	63	71	80	90	100	112	132	160	180	200	225
24 Vdc												
VF		1,1	1,2	1,7	1,8	2,1	3,7	3,2	5			
VFT						2,8	3,1	3,2	5			

## 4. INSTALLATION

### 4.1 Warnings

	<ul style="list-style-type: none"> <li>The non-correct installation of the device could be dangerous for the operator's safety and for the device itself. Carefully follow the assembly instructions below indicated and only refer to qualified electricians and installers.</li> <li>In case of bad functioning or system block the motor is automatically led into neutral state with rotor free to round; be careful not to cause danger, in relation to the using modalities of the machine on which ESV is assembled.</li> <li>The ESV are not designed to work as a brake for the load to which it is connected. If this should occur the system will block, leaving the motor in neutral state, with the rotor free to round. <b>Be careful not to cause danger, in relation to the using modalities of the machine on which ESV is assembled.</b></li> <li>The risks of the ESV use have not to be related to the machine to which it will be assembled.</li> </ul>
---	--

### 4.2 Environmental using conditions

	<p>The device external surface can reach high temperatures (higher than 60°). It is recommended to evaluate the risks on the basis of the use, the kind of environment and the atmosphere in which the device will work.</p>
---	--

The product is due to be connected to machines working in industrial environment.

The working conditions must be compatible with:

- Protection degree IP55
- Environmental temperature variable between 0°C and 40°C .
- Relative humidity <90%, absence of condense and moisture.
- Absence of caustic, inflammable atmosphere or at explosion risk.
- Height up to 1000m (above sea level) as for the data on the plate; at higher height the return power decreases of 9% every 1000 Mt.



If the working environment is particularly dusty, it is recommended to periodically clean the ventilation system. (See Chapter 7, "Maintenance")

### 4.3 Necessary place during the functioning

The functioning place of the device has to enable:

- A right ventilation of the motor and of the box containing the control electronic;
  - An easy opening of the box upper cover an a good access to system inner regulations;
- To satisfy the above specifications, it is necessary to have around the device the following place:

- Not less than 100 mm from the lateral sides of the motor's frames;
- Not less than 150 mm from the cooling fan back protection grille;
- Not less than 250 mm over the control box cover;

If not possible to have distances like the ones above indicated, provide with an equivalent air volume and free circulation with external environment.



However this space should enable an efficient change of air, which is absolutely necessary for the system cooling.



If the working environment is particularly dusty, it is necessary to grant more space than the one indicated and sufficient to enable the periodically cleaning of the ventilation system. (See Chapter 7, "Maintenance").

### 4.4 Placing and installation on the spot

To install ESV in the working position there aren't other prescriptions other than the ones already quoted in paragraph 4.3, "Necessary place to the functioning".

**The installing procedure is the following:**

1. take off the drive shaft protection plug.
2. make sure, if allowed by the application, the device placing can grant an easy access to the command and inside regulation.
3. fix the system by using the motor attack flange (for types B5 or B14) or the frame motor feet (type B3).
4. make sure the fixing screws are correctly clamped.

### 4.5 Connection to electric line

Model	Voltage	Frequency
4T	400V -15% 480V+10%	47Hz to 63Hz



The system requires a supply voltage, alternating three phase 460V +10% 380V -15% and frequency 50Hz o 60Hz in relation to the data on the plate of the specific model.

For the measurement of the electric installation and of the protection switches to be placed in the device please refer to the following schema:

Tab.4.1

Model	In[A]	Fuse [A]	Minimum section cable [mm <sup>2</sup> ]
ESV05 C4T	1,4	2	1,5
ESV10 C4T	1,9	2	1,5
ESV15 C4T	2,6	3	1,5
ESV20 C4T	3,3	4	1,5
ESV30 C4T	4,6	5	1,5
ESV40 C4T	6,2	8	1,5

Model	In[A]	Fuse [A]	Minimum section cable [mm <sup>2</sup> ]
ESV50 C4T	7,9	8	1,5
ESV75 C4T	10,8	12	2,5
ESV100 C4T	14,8	15	2,5
ESV150 C4T	23,3	25	4
ESV200 C4T	28,3	30	6
ESV250 C4T	33,3	35	10
ESV300 C4T	39,9	40	10

-  The indicated cable section is the thinnest one when their length does not exceed 30 Mt. In this way the line drop does not exceed 5% of the power voltage, as specified by the Norm EN60204-1
-  If ESV is installed in an plant with ground fault interrupter, this one should be calibrated for an intervention current **not less than 100 mA** and for a time **not less than 0,1 s**
-  The ground fault interrupter should bear high frequency noise.

System electric connection procedure and preliminary check:

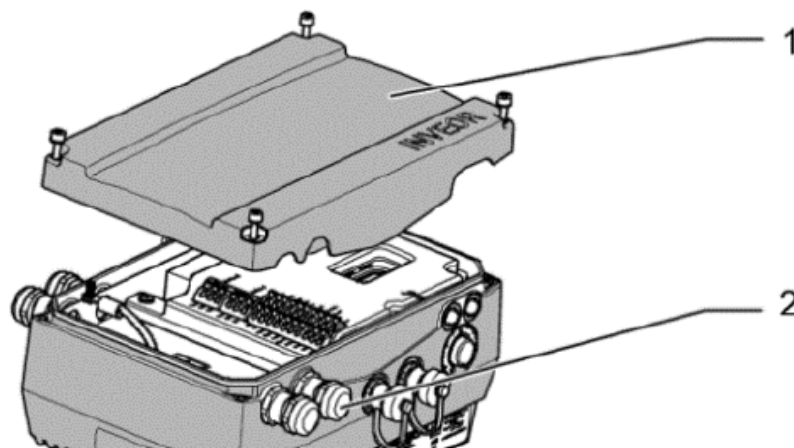

1. Unscrew the screws and then the cover (1) of the control box being careful not to lose screws and gasket;



When opening, pay particular attention because the cover is connected to a ground wire and the I / O model M = the edge of the keyboard membrane

2. insert the power cord into the box through the cable gland (2);
3. Connect the ground wire to the frame of the box through the appropriate screw (indicated by the symbol conventional ground), or equivalently to the PE terminal;
4. Connect line wire L1-L2-L3 (supply=4T);
5. Check that all terminals are tight and that the wires are securely locked;
6. safely lock the cable into place by tightening the appropriate cable glands;
7. make sure that no foreign objects accidentally left inside the box;



Verificare di aver ricollegato gli eventuali cavi scollegati in fase apertura coperchio.

8. Close the cover box carefully tighten all the screws; the tightening torque is:
  - up to ESV 100 (7.5 kW) torque 2 Nm;
  - from ESV 150 (11kw) to ESV 300 (22kW) torque 4 Nm.

**Procedure for the electrical connection of an external fan ESV (separate terminal):**

1. cooling forced is present only in models type VF , VFT
2. Remove the screws and the cover of the terminal box of the servo-ventilation being careful not to lose screws and gasket;
3. Connect the ground wire to the frame of the box through the appropriate screw (indicated by the symbol conventional ground), or equivalently to the PE terminal;
4. For models with separate fan to connect L1-L2-L3 (Vent = VFT) or LN (Vent = VF) use the terminal verify the rear cooling fan is working properly;
5. Close the lid of the box by placing the gasket and carefully tighten all the screws;
6. feed the servo-ventilation;
7. Check that the servo-ventilation to provide the proper amount of air and that some foreign body touches the blades or clogging the grate of the fan cover back;
8. Remove the power supply to power cooling.



ESV must be connected to the sources of electric energy by respecting the rules in force about plant engineering and in the building (EN60204-1 on the machine).

**4.6 Installation**

The user/installer has the responsibility for the safety of his construction, according to the norms UE and national rules. The safety indications in this manual are due to this aim, but they are only about ESV and its use.

For over temperature and over loading see par.5.2 and 6.



During the first test, start ESV with the plastic protection on the drive shaft, because the key can be thrown out for centrifugal force and cause huge damages

While functioning check that the installation do not present too many vibrations. On the contrary, turn ESV off and verify that the coupled organs are well balanced and the base is solid. If while working ESV is too noisy, check the bearings are not worn and need to be replaced (par. 7.4). Before installing ESV it is recommended to check the general state; particularly check the right functioning of the mechanical organ, and most of all the rotation smoothness of the drive shaft. Compare the technical data and the specifications on the allowed use in this manual, in the plate data and in any other documentation enclosed to the item with the right characteristics.

Respect the general indications about good manufacture and preventional technique, the local rules and the machine specifications.

Verify that all electric terminals in the terminal board are well connected, that the voltage and frequency value on the plate are the same of the power supply, from which ESV will be supplied. Otherwise the installation is forbidden.

## 5. MACCHINE USE

### 5.1 Warnings

	<ul style="list-style-type: none"> <li>• It is recommended to use ESV exclusively with the control box cover correctly closed and screwed..</li> <li>• The voltage levels inside the control box are <b>EXTREMELY DANGEROUS</b>. Before opening the cover, disconnect all the conductor phase of the system.</li> <li>• Wait at least five minutes because the inner voltages reach value for the operator's safety.</li> <li>• Make sure all led are switched off.</li> <li>• When closing the control box and before supplying the system, make sure that objects weren't left inside it</li> </ul> <p style="text-align: center;"><b>The non-respect of these safety norms could be very dangerous for the operator and cause irreparable damage to the system.</b></p>
---	--

	<p>Do not remove the back protection of the cooling fan.</p>
---	--

### 5.2 Safety systems

ESV is provided with the following inner electronics protections:

- Undervoltage and overvoltage
- $I^2t$  restriction,
- short circuit,
- motor- drive controller temperature,
- anti-tilt protection,
- stall protection

- Temperature protection electronics: it causes your system to freeze if the temperature inside the control box exceeds the safe operating limit. This can happen if you work more than the rated power of the motor over the rated torque and under specific environmental conditions.

- Protection of torque: causes the block of the system in the case where the load absorbs more than 150% of rated current.

### 5.3 Control, regulation and signalling systems.

The control system ESV is achieved by the control signals available to the interface connectors, keyboard control, control by PC or via the fieldbus

- **Keypad MMI**

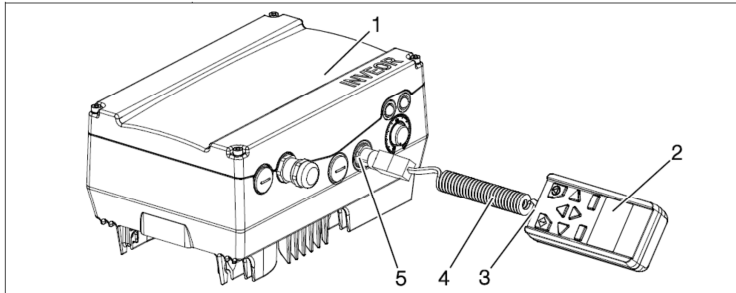
	<table border="1"> <thead> <tr> <th>Button</th> <th>Function</th> </tr> </thead> <tbody> <tr> <td>1</td> <td>INVEOR drive control</td> </tr> <tr> <td>2</td> <td>INVEOR MMI manual control unit</td> </tr> <tr> <td>3</td> <td>RJ11 socket</td> </tr> <tr> <td>4</td> <td>Communication cable</td> </tr> <tr> <td>5</td> <td>M12 socket</td> </tr> </tbody> </table>	Button	Function	1	INVEOR drive control	2	INVEOR MMI manual control unit	3	RJ11 socket	4	Communication cable	5	M12 socket
Button	Function												
1	INVEOR drive control												
2	INVEOR MMI manual control unit												
3	RJ11 socket												
4	Communication cable												
5	M12 socket												

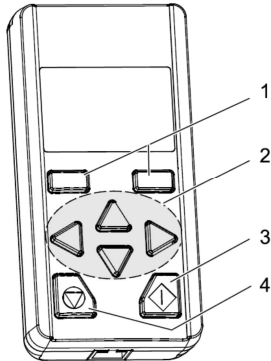
	<b>Button</b>	<b>Function</b>
	1	Confirm and navigation keys
	2	Up/down, increase/decrease and shift functions
	3	Run
4	Stop	

• **PC control by software**

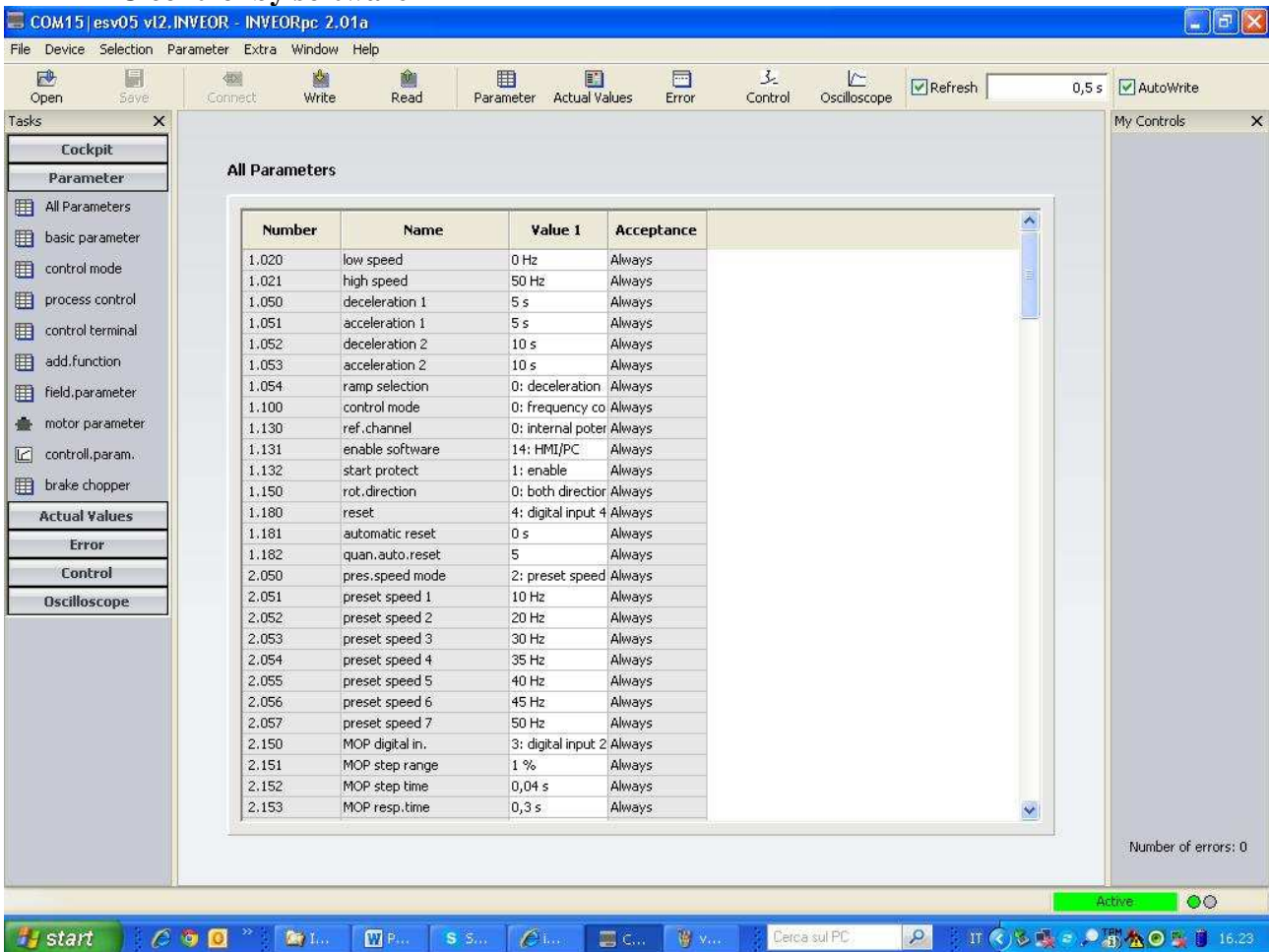

**5.3.1 Start up and stop**

- 1) via the MMI keypad with buttons FWD / STOP, REV / STOP;
- 2) commands via the control signals from the terminal;
- 3) through the SW for PC;
- 4) via fieldbus
- 5) via push buttons on if any.



 Depending on the state of the system the start may occur immediately after the connection to the power supply and with a slight delay, of a few seconds, required for initialization operations of the electronic circuits.

### 5.3.2 Speed rotation regulation

La modalità di variazione di velocità si effettua tramite

- 1) Potentiometer on board (ove presente)
- 2) With keypad on board;
- 3) commands via the control signals from the terminal:
  - a. analog input 0-10volt;
  - b. analog input current 0-20mA
  - c. presettet frequency.
- 4) using SW per PC;
- 5) using Field Bus

### 5.3.3 Ramp regulation acceleration

	Do not absolutely make system regulation operations with the box open and the device supplied.
---	--

The adjustment of the duration of the acceleration and deceleration is achieved by programming the appropriate parameters possibly also using the multi ramp of the digital inputs.

### 5.3.4 Motion enabling

	<b>Do not absolutely regulate the system when the box is open and the device is supplied.</b>
--	---

The Run command is a certification motion.

The parameter that handles the mode is 1.131.

In addition to increase security (ESV is not to be considered as a safety device) can use the protection sull'autostart 1,132.

The model with the keyboard on board ( $I / M = 0$ ) has the Start and Stop buttons on the cover box.

	The status of the disabled device should not be considered as a safe state in which to operate particular activities adjustment or maintenance or other. To reach a state of safety, always make sure that all phases of the system is cut by at least five minutes.
	The blocking feature of autostart is not considered a safe state.

### 5.3.5 Selection of the direction

	Do not absolutely make operations of system regulation when the box is open and the device is supplied.
---	---

How to select the direction of travel can be selected using parameter 1150:

- depends on the reference value
- using an input terminal
- using an analog input
- using the keyboard on board (model  $I / O = M$ )

### 5.3.6 Wiring braking resistance

	Do not absolutely regulate the system regulation when the box is open and the device is supplied.
---	---



After connecting the braking option card to make the connections of the brake resistor.

The braking resistor must be adequately dimensioned in power according to the inertia of the load and the braking time desired. It should take into account the number of cycles per unit of time and carry out the verification thermal application. In any case the resistance value cannot fall below the minimum value in the table, with a value indicative of power to be developed depending on the application.

Model	Minimum limit resistor /max power
ESV05 C4T/ ESV10 C4T/ ESV15 C4T/ ESV20 C4T	100ohm / 5000watt
ESV30 C4T/ESV40 C4T/ESV50 C4T/ESV75 C4T/ESV100 C4T	50ohm / 10000watt
ESV150 C4T/ESV200 C4T/ESV250 C4T/ESV300 C4T	30ohm / 15000watt

## 5.4 Terminal connections

### 5.4.1 power terminal

#### 5.4.1.1 terminal for power up to 7,5 kW (ESV 100)

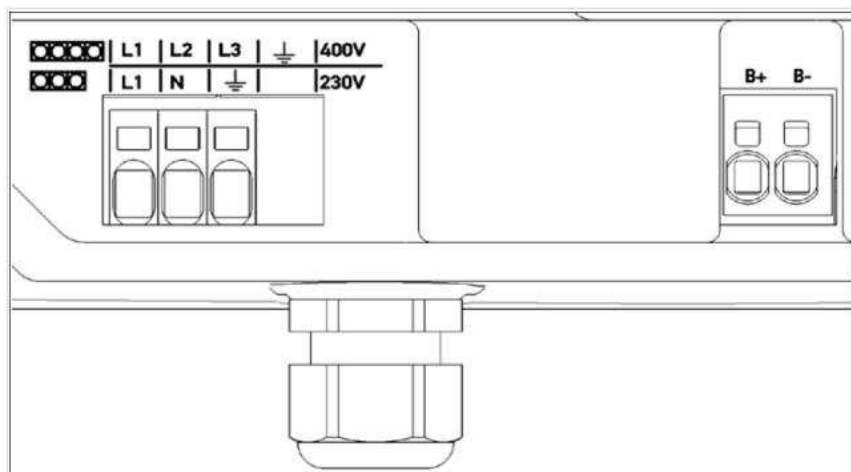

400Vac power supply		
Terminal	lead	Signal
1	L1	phase 1
2	L2	phase 2
3	L3	phase 3
4	GE	Earth

Terminal	lead	Signal
1	B+	Lead for brake resistor +
2	B-	Lead for brake resistor -

<b>Terminal power:</b>	
<ul style="list-style-type: none"> <li>• terminal phases supply</li> <li>• terminal brake resistors</li> </ul>	
<p>The terminals for the mains cable are located inside the drive controller. The INVEOR also has the option of being equipped with terminals for connecting a brake resistor.</p> <p>The configuration may vary depending on the version.</p> <p>Core end sleeves with plastic collars and lugs are recommended.</p>	
Terminals:	Spring force connection (slot screwdriver, max. width 2.5 mm)
Conductor cross-section, rigid	min. 0.2 mm <sup>2</sup> max. 10 mm <sup>2</sup>
Conductor cross-section, flexible	min. 0.2 mm <sup>2</sup> max. 6 mm <sup>2</sup>
Conductor cross-section, flexible with core end sleeve without plastic sleeve	min. 0.25 mm <sup>2</sup> max. 6 mm <sup>2</sup>
Conductor cross-section, flexible with core end sleeve with plastic sleeve	min. 0.25 mm <sup>2</sup> max. 4 mm <sup>2</sup>
2 conductors of the same crosssection, flexible with TWIN-AEH with plastic sleeve	min. 0.25 mm <sup>2</sup> max. 1.5 mm <sup>2</sup>
Conductor cross-section AWG/kcmil	min. 24 max. 8
Length of stripped insulation:	15 mm
Mounting temperature:	-5°C to +100°C

**5.4.1.2 terminal for power from 9,2 up to 22 kW ( ESV 150 to ESV 300)**

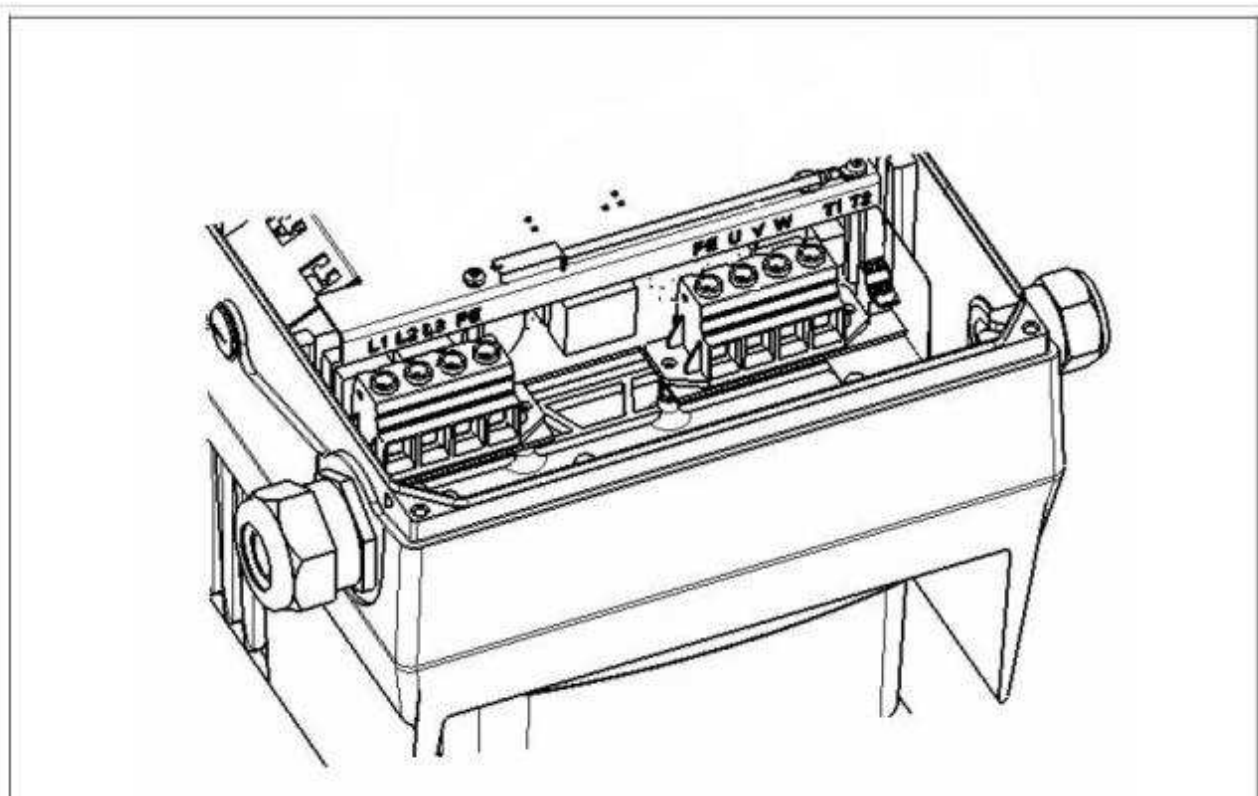

<b>400Vac power supply</b>		
<b>Terminal</b>	<b>lead</b>	
1	L1	Fase 1
2	L2	Fase 2
3	L3	Fase 3
4	GE	Cavo di terra

<b>Terminal</b>	<b>lead</b>	
1	B+	Lead for brake resistor +
2	B-	Lead for brake resistor -

<b>Terminal power:</b>	
<ul style="list-style-type: none"> <li>• <b>terminal phases supply</b></li> <li>• <b>terminal brake resistors</b></li> </ul>	
<p>The terminals for the mains cable are located inside the drive controller. The INVEOR also has the option of being equipped with terminals for connecting a brake resistor.            The configuration may vary depending on the version.            Core end sleeves with plastic collars and lugs are recommended.            Torque min. 2.5 Nm / max. 4.5 Nm</p>	
Conductor cross-section rigid	min. 0.5 mm <sup>2</sup> max. 35 mm <sup>2</sup>
Conductor cross-section, flexible:	min. 0.5 mm <sup>2</sup> max. 25 mm <sup>2</sup>
Conductor cross-section, flexible with core end sleeve without plastic collar	min. 1 mm <sup>2</sup> max. 25 mm <sup>2</sup>
Conductor cross-section, flexible with core end sleeves with plastic sleeve	min. 1.5 mm <sup>2</sup> max. 25 mm <sup>2</sup>
Conductor cross-section AWG/kcmil	min 20 max. 2
2 conductors of the same crosssection, rigid	min. 0.5 mm <sup>2</sup> max. 6 mm <sup>2</sup>
2 conductors of the same crosssection, flexible	min. 0.5 mm <sup>2</sup> max. 6 mm <sup>2</sup>
2 conductors of the same crosssection,flexible with AEH without plastic sleeve	min. 0.5 mm <sup>2</sup> max. 4 mm <sup>2</sup>
2 conductors of the same crosssection,flexible with TWIN-AEH with plastic sleeve	min. 0.5 mm <sup>2</sup> max. 6 mm <sup>2</sup>
AWG according to UL/CUL	min. 20 max. 2

## 5.4.2 command terminal

### 5.4.2.1 complete command terminal (except I/O=M or Y)

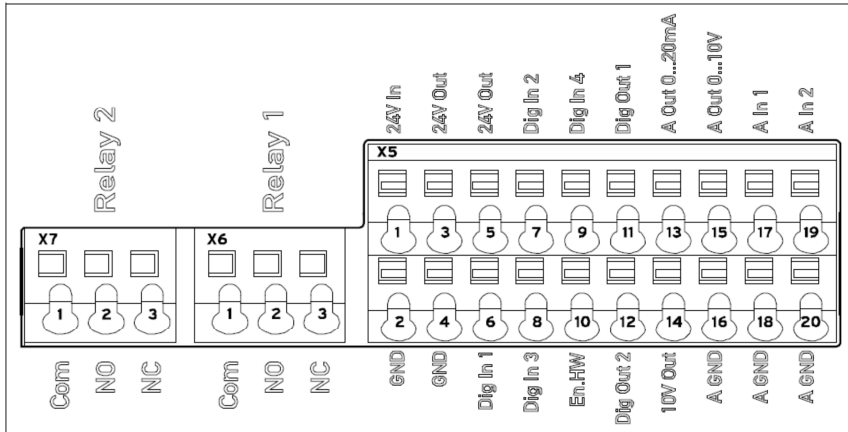

Terminal configuration X5 of the standard application board		
Terminal	lead	Signal
1	24 V In	Ext. power supply
2	GND (ground)	Ground
3	24 V Out	Int. power supply
4	GND (ground)	Ground
5	24 V Out	Int. power supply
6	Dig. In 1	Target value release (parameter 1.131)
7	Dig. In 2	Free (not assigned)
8	Dig. In 3	Free (not assigned)
9	Dig. In 4	Error reset (parameter 1.180)
10	En HW (release)	Enable hardware
11	Dig. Out 1	Fault message (parameter 4.150)
12	Dig. Out 2	Free (not assigned)
13	A. Out 0 ... 20 mA	Actual frequency (parameter 4.100)
14	10 V Out	For ext. voltage divider
15	A. Out 0 ... 10 V	Actual frequency (parameter 4.100)
16	A GND (ground 10 V)	Ground
17	A. In 1	PID feedback (parameter 3.060)
18	A GND (ground 10 V)	Ground
19	A. In 2	Free (not assigned)
20	A GND (ground 10 V)	Ground

Terminal configuration X6 (relè 1) of the standard application board		
Terminal	lead	Signal
1	COM	Common
2	NO	Normal open
3	NC	Normal close

Terminal configuration X7 (relè 2) of the standard application board		
Terminal	lead	Signal
1	COM	Common
2	NO	Normal open
3	NC	Normal close

#### 5.4.2.2 reduced terminal connector (I/O=M or Y)

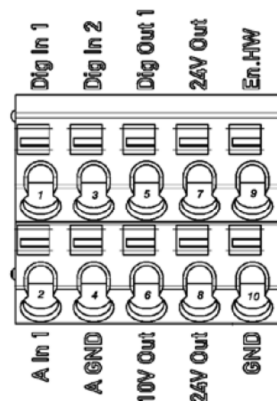

Terminal configuration X5 of the basic application board		
Terminal	lead	Signal
1	Dig. In 1	Target value release (parameter 1.131)
2	A. In 1	Free (not assigned)
3	Dig. In 2	Free (not assigned)
4	A GND (ground 10 V)	Ground
5	Dig. Out 1	Fault message (parameter 4.150)
6	10 V Out	For ext. voltage divider
7	24 V Out	Int. power supply
8	24 V Out	Int. power supply
9	En HW (release)	Enable hardware
10	GND (ground)	Ground

Control signal terminal connector	
Terminals:	Plug terminal clamp with activation button (slot screwdriver, max. width 2.5 mm)
Connection crosssection:	0.5 to 1.5 mm <sup>2</sup> , single-wire, AWG 20 to AWG 14
Connection crosssection:	0.75 to 1.5 mm <sup>2</sup> , fine-wired, AWG 18 to AWG 14
Connection crosssection:	0.5 to 1.0 mm <sup>2</sup> , fine-wired (core end sleeves with and without plastic collars)
Length of stripped insulation:	9 to 10 mm

### 5.4.2.2 Membrane keypad (only for I/O=M)

As an option, the devices of the ESV family are also available as a variant with an integrated foil keypad. This keypad can be used to operate the drive controller locally.

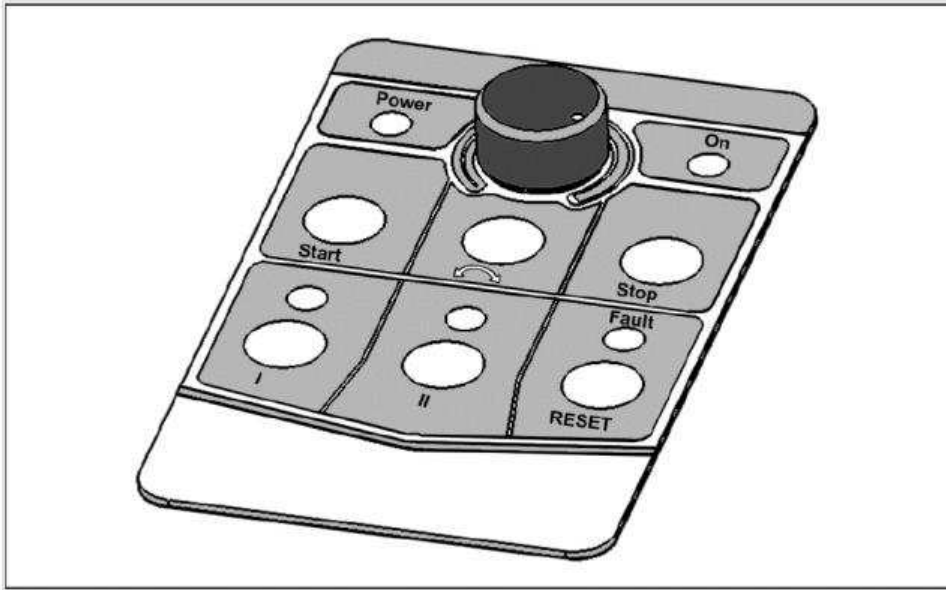

The following functionalities can be realised using the integrated foil keypad:

- **Target value specification:** A target value (parameter 1.130) can be specified using the potentiometer integrated in the foil keypad (select internal potentiometer).
- **Target value approval:** The start and stop keys integrated in the foil keypad (select foil keypad) can be used to approve the drive software (parameter 1.131).
- **Direction of rotation V1:** The direction of rotation (parameter 1.150) can be changed using the key integrated in the foil keypad (select foil keypad, direction of rotation key). The direction of rotation can only be changed when the motor is running.
- **Direction of rotation V2:** The direction of rotation (parameter 1.150) can be changed using keys I and II integrated in the foil keypad (select foil keypad, key I clockwise/key II anti-clockwise via stop). The direction of rotation can only be changed when the motor is stationary. The integrated LEDs indicate the current direction of rotation.
- **Direction of rotation V3:** The direction of rotation (parameter 1.150) can be changed using keys I and II integrated in the foil keypad (select foil keypad, key I clockwise/key II anti-clockwise always). The direction of rotation can be changed when the motor is running and stationary. The integrated LEDs indicate the current direction of rotation.
- **Acknowledgement function:** An error can be acknowledged (parameter 1.180) using the reset key integrated in the foil keypad (select foil keypad).
- **Motor potentiometer:** A motor potentiometer (parameter 2.150) can be realised using the configurable keys I and II integrated in the foil keypad (MOP digit.inp.). This function can be used to increase or decrease the target value. The integrated LEDs indicate when the minimum/maximum target value is reached. To activate this function, the target value specification (parameter 1.130) must be set to motor potentiometer!
- **Fixed frequency:** Two fixed frequencies (parameter 2.050) can be realized using the configurable keys I and II integrated in the foil keypad (MOP digit.inp.). This function can be used to increase or decrease the target value. The integrated LEDs indicate the target value currently selected.

LED	Meaning
Power	Lights up as soon as there is a voltage supply.
On	Lights up as soon as there is a voltage supply.
Fault	Lights up when there is an error. Flashes as soon as an error can be acknowledged.



**INFORMATION:**



To set parameters for these functions, you need PC software version 1.17 or higher.

**5.4.1 Electrical wiring and connections**

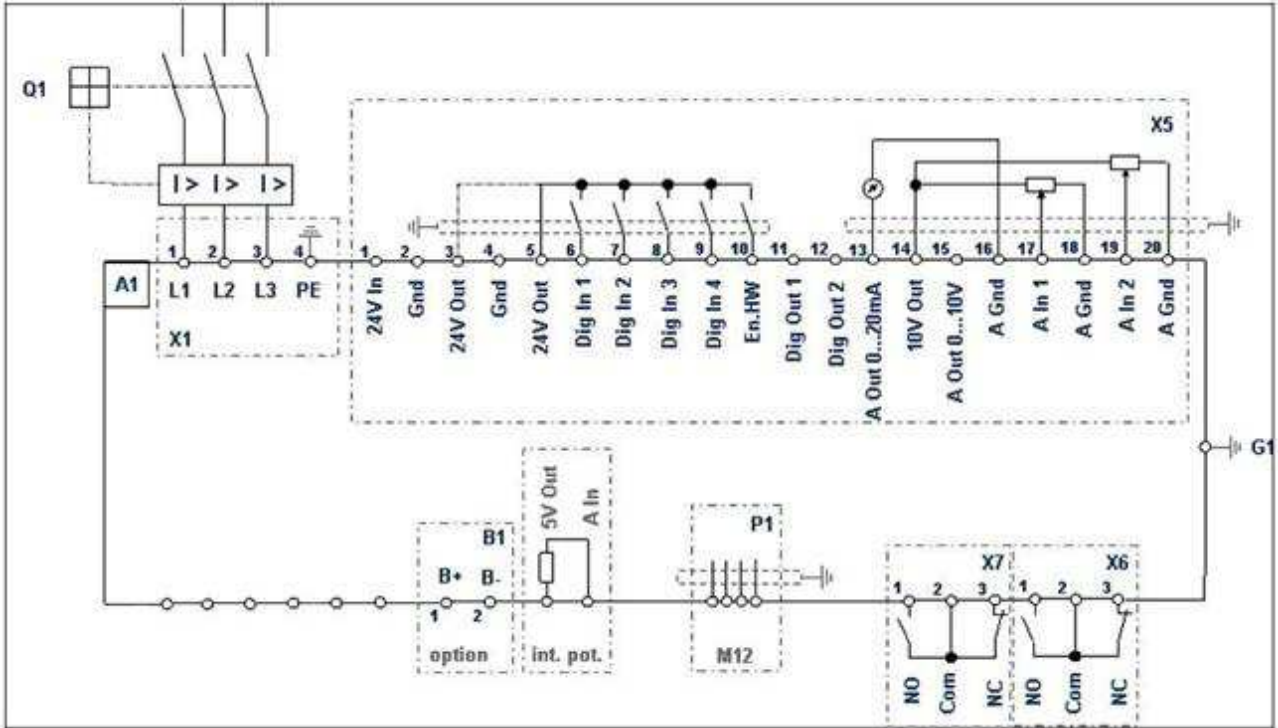
**Example of power supply of a three-phase model terminal complete**



## 6. DIAGNOSTIC AND INTERVENTION

	<p>Most of the verification of the operation and diagnosis of the device does not require the opening of the control box.</p> <p>If it is essential to get inside before opening the cover disconnect all the phases of the system and <b>wait at least five minutes</b> for the internal voltage reach a safe level for the operator's safety.</p> <p>In any case, positively ensure that:</p> <ul style="list-style-type: none"><li>- The electric power supply circuit is visibly dissected and placed under the control of the maintainer.</li><li>- All mechanical masses kinematically connected to the drive shaft are firmly and locked so that will not occur sudden restarts to drive the shaft by mechanical external.</li></ul>
	<p>Danger due to electrical shock and discharge. Wait two minutes (discharge time of the capacitors) after shut-down</p>

**In case of breakdown or malfunction report through the ESV:**











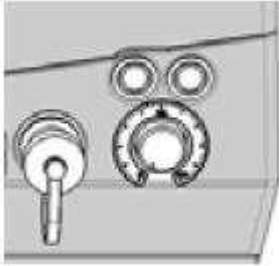













1. 2 led with code error



2. keyboard MMI
3. software installed on PC



## 6.1 Diagnostic LED

			<b>LED off</b>
			<b>LED on</b>
			<b>LED lighting</b>
			<b>LED fast lighting</b>
<b>LED Red</b>	<b>LED green</b>	<b>Description</b>	
		Boot loader active (flashing in turn)	
		Ready for operation (activate En_HW for operation)	
		Operation / ready	
		Warning	
		Error	
		Identification of motor data	
		Initialization	
		Firmware update	
		Bus error operation	
		Bus error ready for operation	

## 6.2 Error List

The driver controller shuts down if an error occurs. Consult the flash code table / PC tool for the corresponding error numbers.

	<p>Error messages can only be acknowledged once the error has been remedied. Error messages can be acknowledged as follows:</p> <ul style="list-style-type: none"> <li>• digital input (can be programmed)</li> <li>• using MMI (handheld controller )</li> <li>• auto acknowledgement (parameter 1.181, page 82)</li> <li>• switch device off and on again</li> <li>• via field bus (CANOpen, Profibus DP, EtherCAD)</li> </ul>
---	--

The following section contains a list of possible error messages. Please contact the STM service department if you encounter errors that are not listed here.

N°	Error	Description	Possible Causes / solutions
1	Undervoltage 24 V application	Supply voltage for the application is less than 15 V	24 V supply overload
2	Overvoltage 24 V Application	Supply voltage for the application is greater than 31 V	Internal 24 V supply is not OK or external supply is not OK
6	Customer PLC version Error	The version of the customer PLC doesn't match the device firmware	Check the version numbers of the customer PLC and device firmware
8	Communication application<>power	Internal communication between the application plate and the power-conducting plate is not OK	EMC interference
10	Parameter distributor	The internal distribution of parameters during initialization failed	Parameter set is incomplete
11	Time-out power	The power part does not respond	Operation with 24 V without mains feed-in
13	Cable break at analogue in1 (4-20 mA / 2-10 V)	Current or voltage is less than the lower limit of analogue input 1 (monitoring for this error is activated automatically by setting parameter 4.021 to 20 %).	Cable break, faulty external Sensor
14	Cable break at analogue in 2 (4-40 mA / 2-10 V)	Current or voltage is less than the lower limit of analogue input 2 (monitoring for this error is activated automatically by setting parameter 4.021 to 20 %)	Cable break, faulty external sensor
15	Stall detection	The drive shaft of the motor is stalled. 5.080	Remove the blockage
18	Excess temperature for frequency converter application	Inner temperature too high	Insufficient cooling, low motor speed and high torque, switching frequency too high.
21	Bus time-out	No response from bus sarin unit or MMI/PC	Check bus wiring
22	Acknowledgement error	The number of maximum automatic acknowledgements (1.182) was exceeded	Check error history and remedy error

<b>N°</b>	<b>Error</b>	<b>Description</b>	<b>Possible Causes / solutions</b>
23	External fault 1	The parameterised fault input is active. 5.010	Correct the external fault
24	External fault 2	The parameterised fault input is active. 5.011	Correct the external fault
25	Motor detection	Motor identification error	Check ESV/motor and PC / MMI / ESV connections / restart motor identification
32	Trip IGBT	Protection of the IGBT module against overcurrent has been triggered	Short circuit in the motor or motor feed line / controller settings
33	Oversvoltage of intermediate circuit	The maximum intermediate circuit voltage has been exceeded	Feedback by motor in generator mode / mains voltage too high / faulty setting for rotation speed controller / brake resistor not connected or defective / ramp times too short
34	Undersvoltage of intermediate circuit	The minimum intermediate circuit voltage has not been reached	Mains voltage too low, mains connection defective / check wiring
35	Excess motor temperature	Motor PTC has been triggered	Overload of the motor (e.g. high torque at low motor speed) / ambient temperature too high
36	Power failure		A phase is missing / mains voltage has been disrupted
38	Excess IGBT module temperature	Excess IGBT module temperature	Insufficient cooling, low motor speed and high torque, switching frequency too high
39	Overcurrent	Maximum output current of drive controller exceeded	Insufficient cooling / low motor speed and high torque / switching frequency too high / ramp times too low / brake not open
40	Excess frequency converter temperature	Inner temperature too high	Insufficient cooling / low motor speed and high torque / switching frequency too high permanent overload / reduce ambient temperature / check fan
42	LT motor protection shutoff	The internal LT motor protection (can be parameterised) has been triggered	Permanent overload
43	Ground leak	Ground leak during a motor Phase	Insulation fault
45	Motor connection disrupted	No motor current in spite of control through frequency converter	No motor connected
46	Motor parameters	Plausibility check for motor parameters failed	Parameter set not OK
47	Drive controller parameters	Plausibility check for drive controller parameters failed	Parameter set not OK, motor type 33.001 and control method 34.010 not plausible

N°	Error	Description	Possible Causes / solutions
48	Type plate data	No motor data entered	Please enter the motor data according to the type plate
49	Power class restriction	Max. overload of the drive controller exceeded for more than 60 sec.	Check application / reduce load / use larger drive controller

NOTE

 on the fields possible solutions are intended like the most common methods of solution

 If any alarms reappear even after the adoption of the remedies suggested in possible solutions, contact your service representative STM SPA

 In case of non-functioning or system block the motor's system is disconnected and the rotor is free to round; be careful this behaviour and the use modalities of the machine to which ESV is assembled cannot cause dangerous situations. Necessary to anticipate the consequences of this behavior.

## 7. MANTEINANCE

### 7.1 Warnings

 The user cannot maintain or repair ESV components. In case of damages or functioning problems contact the authorised service only.

### 7.2 Cleaning and ordinary maintenance

The only ordinary maintenance ESV requires is the periodical cleaning check of the cooling system. This operation must have a monthly frequency if the device works in normal environmental conditions and weekly or more frequently it works in particularly dusty rooms or which cause the deposit of substances that could reduce the cooling system efficacy

 During the maintenance and cleaning operation make sure the control box cover and the fairled of the supply cable are fixed in the right way, not to let dust and dirty enter the device, causing possible problems to the electronics.

For ordinary maintenance follow this **procedure**:

1. Disconnect all ESV phase conductors;
2. Check all the motor's side cooling fin, the fan back protection grid and the cooling fins in the back side of the control box are free from dust deposit, rubbish, dirty;
3. On the contrary clean them by using torns or compressed air with medium pressure. In extreme cases wash the device with a weak jet of water, letting then it dry;
4. Supply the system again;
5. Check the cooling is easy inside all the cooling fins, otherwise clean it again.

### **7.3 Periodical inspection**

It is recommended to make it periodically, according on using conditions and however at least monthly:

- a. Maintenance of the free ventilation space (par. 4.3).
- b. Motor cleaning (par. 7.2).
- c. Quality of wiring connections (par. 4.5).
- d. Check of the right and solid connection of the motor to its mechanic load.

If between the supply and the start-up have passed more than 4 years but in good storing conditions (dry environment and free from dust and vibrations), or more than 2 years in bad conditions, it is due to replace the motor bearings.

The motor humidity must be taken away by using an external heating.

### **7.4 Replace the bearings and other parts**

Contact STM, avoiding disassembling.

## **8. PLACING OUT OF SERVICE**

In case ESV is not working anymore and it is thrown away, please note that:

- There is an explosion danger of the electrolytic condensers inside the control box if the product is kept at high temperatures, (like in incinerators);
- The plastic material could release, if burned, venomous gases and very toxic;
- ESV is considered as a «special, non-dangerous » product for UE laws. It is necessary to dispose it following the local norms and regulations

## 9. CONFIGURATION PARAMETERS

### 9.1 USER Menù

### 9.2 Parameter description

Tabella parameter structure table

1	2	3	4	5	6
1.100	Selection ramp		Unit: integer		
Relationship to parameter: 1.130 1.131 2.051 to 2.057 3.050 to 3.071	Parameter manual: p.xy	Transfert status: 2	min: 0	max: 3	Own value (to be entered!)
	def.: 0				
<p>Selecting the operating mode.</p> <p>After software release (1.131) and hardware release, the drive control runs as follows:</p> <p>0 = frequency control mode, with the target value of the selected reference channel (1.130)</p> <p>1 = PID process control, with the target value of the PID process control (3.050–3.071)</p> <p>2 = preset speed mode, with the frequencies specified by parameters 2.051–2.057</p> <p>3 = selection from INVEOR soft PLC</p>					
9			8		
					7

Field menings			
1	Parameter number	6	Unit
2	Description in the parameter manual on page .....	7	Field for entering an own value
3	Parameter name	8	Explanation of the parameter
4	Transfer status 0 = switch drive controller off and on for transfer 1 = at speed of 0 2 = during operation	9	Other parameters related to this parameter.
5	Value range (from – to factory setting)		

**Note: there are different levels of visibility.**

The following are the levels in increasing visibility for the keyboard MMI and PC SOFTWARE:

1. **Base:** all the times that you will turn in position "reduced visibility parameters" automatically
2. **Expert:** mode can be enabled using parameter (50) Expert Mode
3. **From PC using the software:** Parameter visible only from a PC but not keyboard MMI.

### 9.2.1 Basic parameters

1.020	Minimum speed		Unit : Hz	
Relationship to parameter: 1.150 3.070	Parameter manual: p.xy	Transfert status: 2	min: 0	Own value (to be entered!)
			max: 400	
	def.: 0			
	<p>The low speed is the frequency provided by the drive control as soon as it is released and no additional target value is pending. This frequency is not reached if acceleration is carried out while the drive is not moving. the frequency inverter is blocked. The frequency is then reduced to 0 Hz before it is blocked. the frequency inverter reverses (1.150). The revolving field is reversed at 0 Hz. the stand-by function (3.070) is active.</p>			

1.021	Maximum speed		Unit : Hz	
Relationship to parameter: 1.050 1.051	Parameter manual: p.xy	Transfert status: 2	min: 5	Own value (to be entered!)
			max: 400	
	def.: 50			
	<p>The high speed is the frequency produced by the inverter depending on the reference.</p>			

1.050	Deceleration 1		Unit : s	
Relationship to parameter: 1.021 1.054	Parameter manual: p.xy	Transfert status: 2	min: 0,1	Own value (to be entered!)
			max: 1000	
	def.: 5			
	<p>Deceleration 1 is the time that the inverter takes to brake to 0 Hz from the high speed (1.021). If the set deceleration time cannot be reached, the fastest possible deceleration time is implemented.</p>			

1.051	Acceleration 1		Unit : s	
Relationship to parameter: 1.021 1.054	Parameter manual: p.xy	Transfert status: 2	min: 0,1	Own value (to be entered!)
			max: 1000	
	def.: 5			
	<p>Acceleration 1 is the time that the inverter takes to accelerate from 0 Hz to the high speed. The acceleration time can be increased as a result of certain circumstances, e.g. if the drive control is overloaded.</p>			

1.052	Deceleration 2		Unit : s	
Relationship to parameter: 1.021 1.054	Parameter manual: p.xy	Transfert status: 2	min: 0,1	Own value (to be entered!)
			max: 1000	
	def.: 5			
	<p>Deceleration 2 is the time that the inverter takes to brake to 0 Hz from the high speed (1.021). If the set deceleration time cannot be reached, the fastest possible deceleration time is implemented.</p>			

1.053	Acceleration 2		Unit : s		
Relationship to parameter: 1.021 1.054	Parameter manual: p.xy	Transfert status: 2	min:	0,1	Own value (to be entered!)
			max:	1000	
			def.:	5	
	Acceleration 2 is the time that the inverter takes to accelerate from 0 Hz to the high speed. The acceleration time can be increased as a result of certain circumstances, e.g. if the drive control is overloaded.				

1.054	Ramp selection		Unit : integer		
Relationship to parameter: 1.050 to 1.054	Parameter manual: p.xy	Transfert status: 2	min:	0	Own value (to be entered!)
			max:	6	
			def.:	0	
	Selection of used ramp pair  0 = deceleration 1 (1.050) / acceleration 1 (1.051) 1 = deceleration 2 (1.052) / acceleration 2 (1.053) 2 = digital input 1 (false = ramp pair 1 / true = ramp pair 2) 3 = digital input 2 (false = ramp pair 1 / true = ramp pair 2) 4 = digital input 3 (false = ramp pair 1 / true = ramp pair 2) 5 = digital input 4 (false = ramp pair 1 / true = ramp pair 2) 6 = INVEOR soft PLC				

1.100	Control mode		Unit : integer		
Relationship to parameter: 1.130 1.131 2.051 to 2.057 3.050 to 3.071	Parameter manual: p.xy	Transfert status: 2	min:	0	Own value (to be entered!)
			max:	3	
			def.:	0	
	Selecting the operating mode.  After software release (1.131) and hardware release, the drive control runs as follows:  0 = frequency control mode, with the target value of the selected reference channel (1.130) 1 = PID process control, with the target value of the PID process control (3.050–3.071) 2 = preset speed mode, with the frequencies specified by parameters 2.051–2.057 3 = selection from INVEOR soft PLC				



1.130	Speed reference		Unit : integer	
Relationship to parameter: 3.062 to 3.069	Parameter manual: p.xy	Transfert status: 2	min: 0	Own value (to be entered!)
			max: 10	
			def.: 0	
<p>Determines the source from where the reference is to be read.</p> <p>0 = internal potentiometer 1 = analogue input 1  2 = analogue input 2  3 = MMI/PC  4 = SAS/MODBUS  6 = motor potentiometer  7= total analogue inputs 1 and 2  8 = PID preset reference mode (3.062)  9 = field bus  10 = reference from INVEOR soft PLC</p>				

1.131	Enable software		Unit : integer	
Relationship to parameter: 1.132 1.150 2.050 4.030 4.050	Parameter manual: p.xy	Transfert status: 2	min: 0	Own value (to be entered!)
			max: 14	
			def.: 0	
<p> <b>WARNING</b></p> <p>The motor may start immediately, depending on the change made.  Selection of the source for the control release.</p> <p>0 = digital input 1  1 = digital input 2  2 = digital input 3  3 = digital input 4  4 = analogue input 1 (has to be selected in parameter 4.030)  5 = analogue input 2 (has to be selected in parameter 4.050)  6 = field bus  7 = SAS/MODBUS  8 = digital input 1 right / digital input 2 left 1.150 must be set to "0"  9 = autostart:  10 = INVEOR Soft-PLC  11 = preset frequency input (all inputs which are selected in parameter 2.050)  12 = internal potentiometer  13 = membrane keyboard (start &amp; stop buttons)  14 = MMI/PC (tramite i tasti verde e rosso di MMI)</p> <p>The motor may start immediately if hardware is enabled (En.Hw. Fig. 8) and a reference has been provided.  This cannot be prevented even with parameter 1.132.</p>				

1.132	Start protect		Unit : integer	
Relationship to parameter: 1.131	Parameter manual: p.xy	Transfert status: 2	min: 0	Own value (to be entered!)
			max: 6	
	def.: 1			
	Selection of behaviour in response to enabling software (parameter 1.131). No effect if autostart was selected.  0 = immediate start when high signal is received at start input of control release 1 = start only if rising shoulder at start input of control release 2 = digital input 1 (function active at high signal level) 3 = digital input 2 (function active at high signal level) 4 = digital input 3 (function active at high signal level) 5 = digital input 4 (function active at high signal level) 6 = INVEOR soft PLC			

1.150	Direction of rotation		Unit : integer	
Relationship to parameter: 1.131 4.030 4.050	Parameter manual: p.xy	Transfert status: 2	min: 0	Own value (to be entered!)
			max: 12	
	def.: 0			
	Selecting the direction of rotation specification  0 = dependent on target value (depending on the plus or minus sign of the target value: positive: forward; negative: backwards) 1 = forwards only (direction of rotation cannot be changed) 2 = backwards only (direction of rotation cannot be changed) 3 = digital input 1 (0 V = forwards, 24 V = backwards) 4 = digital input 2 (0 V = forwards, 24 V = backwards) 5 = digital input 3 (0 V = forwards, 24 V = backwards) 6 = digital input 4 (0 V = forwards, 24 V = backwards) 7 = reference from INVEOR soft PLC 8 = analogue input 1 (must be selected in parameter 4.030) 9 = analogue input 2 (must be selected in parameter 4.050) 10 = membrane keyboard button for changing direction of rotation (only when motor is running) 11 = membrane keyboard button 1 forwards / 2 reverse (change always possible) 12 = membrane keyboard button 1 forwards			

1.180	Reset		Unit : integer	
Relationship to parameter: 1.181 1.182	Parameter manual: p.xy	Transfert status: 2	min: 0	Own value (to be entered!)
			max: 5	
			def.: 4	
	<p>Selection of the source for error confirmation.</p> <p>Errors can only be confirmed once the error has been remedied. Some errors can only be confirmed by switching the control off and then on again, see list of errors. Auto-confirmation via parameter 1.181.</p> <p>0 = no manual confirmation possible 1 = rising shoulder at digital input 1 2 = rising shoulder at digital input 2 3 = rising shoulder at digital input 3 4 = rising shoulder at digital input 4 5 = membrane keyboard (acknowledgement button)</p>			

1.181	Automatic reset		Unit : s	
Relationship to parameter: 1.181 1.182	Parameter manual: p.xy	Transfert status: 2	min: 0	Own value (to be entered!)
			max: 1 000 000	
			def.: 0	
	<p>In addition to the reset function (1.180), an automatic reset can be selected.</p> <p>0 = no automatic confirmation &gt; 0 = time for automatic reset of error in seconds</p>			

1.182	Numbre of automatic reset		Unit : integer	
Relationship to parameter: 1.181 1.182	Parameter manual: p.xy	Transfert status: 2	min: 0	Own value (to be entered!)
			max: 500	
			def.: 5	
	<p>In addition to the automatic reset (1.181), it is possible to limit the maximum number of automatic resets here.</p> <p>0 = no restriction on automatic confirmations &gt; 0 = maximum number of permitted automatic confirmations</p>			

## 9.2.2 Preset speed mode

This mode has to be selected in parameter 1.100, see also the section on selecting the operating mode

<b>2.050</b>	<b>Preset speed mode</b>		<b>Unit : integer</b>	
Relationship to parameter: 1.100 2.050 to 2.057	Parameter manual: p.xy	Transfert status: 2	min:	0
			max:	3
			def.:	2
	Own value (to be entered!)			
0 = Digital In 1 (preset speed 1) (2.051) 1 = Digital In 1, 2 (preset speeds 1 - 3) (2.051 to 2.053) 2 = Digital In 1, 2, 3 (preset speeds 1 - 7) (2.051 to 2.057) 3 = membrane keyboard (button 1 = fixed frequency 1 / button 2 = fixed frequency 2)				

<b>Da 2.051 a 2.057</b>	<b>Preset speed</b>		<b>Unit : Hz</b>	
Relationship to parameter: 1.020 1.021 1.150 2.050	Parameter manual: p.xy	Transfert status: 2	min:	-400
			max:	+400
			def.:	0
	Own value (to be entered!)			
The frequencies that are to be output at the digital inputs 1 - 3 specified in parameter 2.050 depending on the switching patterns. See chapter 5.2.1 on preset speeds.				

DI 3	DI 2	DI 1	Selection	Parameter	Presetting
0	0	0	Min. frequenza	1.020	0 Hz
0	0	1	Preset speed 1	2.051	10 Hz
0	1	0	Preset speed 2	2.052	20 Hz
0	1	1	Preset speed 3	2.053	30 Hz
0	0	0	Preset speed 4	2.054	35 Hz
0	0	1	Preset speed 5	2.055	40 Hz
0	1	0	Preset speed 6	2.056	45 Hz
0	1	1	Preset speed 7	2.057	50 Hz

### 9.2.3 Motorised potentiometer

This mode must be selected in parameter 1.130. This function can be used as a source of target values for frequency setting mode as well as for the PID process controller.

2.150	MOP ingresso digitale		Unit : integer		
Relationship to parameter: 1.130 4.030 4.050	Parameter manual: p.xy	Transfert status: 2	min:	0	Own value (to be entered!)
			max:	8	
			def.:	3	
	Selection of the source for increasing and reducing the target value 0 = Digital In 1 + / Digital In 2 - 1 = Digital In 1 + / Digital In 3 - 2 = Digital In 1 + / Digital In 4 - 3 = Digital In 2 + / Digital In 3 - 4 = Digital In 2 + / Digital In 4 - 5 = Digital In 3 + / Digital In 4 - 6 = Analogue In 1 + / Analogue In 2 - (must be selected in parameter 4.030 / 4.050) 7 = reference from customer PLC 8 = membrane keyboard (button 1 - / button 2 +)				

2.151	MOP step range		Unit : %		
Relationship to parameter: 1.020 1.021	Parameter manual: p.xy	Transfert status: 2	min:	0	Own value (to be entered!)
			max:	100	
			def.:	1	
	Increments at which the target value changes per keystroke.				

2.152	MOP step time		Unit : s		
Relationship to parameter:	Parameter manual: p.xy	Transfert status: 2	min:	0,02	Own value (to be entered!)
			max:	1000	
			def.:	0,04	
	Indicates the time during which the target value is totalled with a permanent signal.				

2.153	MOP respnse time		Unit : s		
Relationship to parameter:	Parameter manual: p.xy	Transfert status: 2	min:	0,02	Own value (to be entered!)
			max:	1000	
			def.:	0,03	
	Indicates the time for which the signal is considered permanent.				

2.154	MOP respnse time		Unit : integer		
Relationship to parameter:	Parameter manual: p.xy	Transfert status: 2	min:	0	Own value (to be entered!)
			max:	1	
			def.:	0	
	Defines whether the target value of the motor potentiometer is retained even after power outage. 0 = disable 1 = enable				

## 9.2.4 PID process controller

This mode has to be selected in parameter 1.100, the target value source has to be selected in parameter 1.130, see also chapter 5.2.1, “Explanation of operating modes – preset speed”.

<b>3.050</b>		<b>PID proportional gain</b>		<b>Unit :</b>	
Relationship to parameter: 1.100 1.130	Parameter manual: p.xy	Transfert status: 2	min:	0	Own value (to be entered!)
			max:	100	
			def.:	0	
Proportional share of PID controller					
<b>3.051</b>		<b>PID integral gain</b>		<b>Unit : 1/s</b>	
Relationship to parameter: 1.100 1.130	Parameter manual: p.xy	Transfert status: 2	min:	0	Own value (to be entered!)
			max:	100	
			def.:	0	
Integral share of PID controller					
<b>3.052</b>		<b>PID derivative gain</b>		<b>Unit : s</b>	
Relationship to parameter: 1.100 1.130	Parameter manual: p.xy	Transfert status: 2	min:	0	Own value (to be entered!)
			max:	100	
			def.:	0	
Differential share of PID controller					
<b>3.060</b>		<b>PID feedback</b>		<b>Unit : integer</b>	
Relationship to parameter: 1.100 1.130 3.061	Parameter manual: p.xy	Transfert status: 2	min:	0	Own value (to be entered!)
			max:	2	
			def.:	0	
Selection of the input source from which the feedback for the PID process controller is imported:  0 = analogue input 1 1 = analogue input 2					
<b>3.061</b>		<b>PID inverted</b>		<b>Unit : integer</b>	
Relationship to parameter: 3.060	Parameter manual: p.xy	Transfert status: 2	min:	0	Own value (to be entered!)
			max:	1	
			def.:	0	
The source of the feedback (parameter 3.060) is inverted  0 = disable 1 = enable					
<b>Da 3.062 a 3.068</b>		<b>PID preset reference</b>		<b>Unit : %</b>	
Relationship to parameter: 1.130 3.069	Parameter manual: p.xy	Transfert status: 2	min:	0	Own value (to be entered!)
			max:	100	
			def.:	0	
The PID preset reference depending on the switching patterns is to be issued at the digital inputs 1 – 3 specified in parameter 3.069 (has to be selected in parameter 1.130).					

<b>3.069</b>	<b>PID preset reference mode</b>		<b>Unit : integer</b>	
Relationship to parameter: 1.130 Da 3.062 a 3.068	Parameter manual: p.xy	Transfert status: 2	min: 0	Own value (to be entered!)
			max: 2	
def.: 0				
Selection of the digital inputs used for fixed frequencies				
0 = Digital In 1 (PID preset reference 1) (3.062)				
1 = Digital In 1, 2 (PID preset references 1 – 3) (3.062 to 3.064)				
2 = Digital In 1, 2, 3 (PID preset references 1 – 7) (3.062 to 3.068)				

<b>3.070</b>	<b>PID stand-by time</b>		<b>Unit : s</b>	
Relationship to parameter: 1.120	Parameter manual: p.xy	Transfert status: 2	min: 0	Own value (to be entered!)
			max: 2	
def.: 0				
If the drive control runs for the set time at the low speed (parameter 1.020), the motor is stopped (0 Hz), see also Chapter 5.2.1, “PID process control”				
0 = disable				
> 0 = waiting time until stand-by function is enabled				

<b>3.071</b>	<b>PID stand-by hysteresis</b>		<b>Unit : %</b>	
Relationship to parameter: 3.060	Parameter manual: p.xy	Transfert status: 2	min: 0	Own value (to be entered!)
			max: 50	
def.: 0				
Condition for waking up the PID controller from stand-by.				
Once the control difference exceeds the set value as %, the control begins again, see also “Control mode (parameter 1.100) – PID controller”.				

<b>3.07?</b>	<b>PID dry run time</b>		<b>Unit : ?</b>	
Relationship to parameter:	Parameter manual: p.xy	Transfert status: 2	min: 0	Own value (to be entered!)
			max: 100	
def.: 0				

<b>3.07?</b>	<b>PID ref min</b>		<b>Unit : %</b>	
Relationship to parameter:	Parameter manual: p.xy	Transfert status: 2	min: 0	Own value (to be entered!)
			max: 100	
def.: 100				

<b>3.07?</b>	<b>PID ref max</b>		<b>Unit : ?</b>	
Relationship to parameter:	Parameter manual: p.xy	Transfert status: 2	min: 0	Own value (to be entered!)
			max: 100	
def.: 100				

## 9.2.5 Analogue inputs

For analogue inputs 1 and 2 (AIx display AI1/AI2)

4.020/4.050		AIx reference type		Unit : integer	
Relationship to parameter:	Parameter manual: p.xy	Transfert status: 2	min: 1	max: 2	Own value (to be entered!)
	Function of analogue inputs 1/2: 1 = voltage input 2 = current input				
4.021/4.051		AIx minimum input		Unit : %	
Relationship to parameter:	Parameter manual: p.xy	Transfert status: 2	min: 1	max: 100	Own value (to be entered!)
	def.: 0				
Specifies the minimum value of the analogue inputs as a percentage of the range.  Example: 0...10 V or 0...20 mA = 0%...100% 2...10 V or 4...20 mA = 20%...100%					
4.022/4.052		AIx reference input		Unit : %	
Relationship to parameter:	Parameter manual: p.xy	Transfert status: 2	min: 1	max: 100	Own value (to be entered!)
	def.: 100				
Specifies the maximum value of the analogue inputs as a percentage of the range.  Example: 0...10 V or 0...20 mA = 0%...100% 2...10 V or 4...20 mA = 20%...100%					
4.023/4.053		AIx dead time		Unit : %	
Relationship to parameter:	Parameter manual: p.xy	Transfert status: 2	min: 1	max: 100	Own value (to be entered!)
	def.: 100				
Dead time as percentage of the range of the analogue inputs.					
4.024/4.054		AIx filter time		Unit : s	
Relationship to parameter:	Parameter manual: p.xy	Transfert status: 2	min: 0,02	max: 1,00	Own value (to be entered!)
	def.: 0				
Filter time of analogue inputs in seconds.					
4.030/4.060		AIx funzione		Unit : integer	
Relationship to parameter:	Parameter manual: p.xy	Transfert status: 2	min: 0	max: 1	Own value (to be entered!)
	def.: 0				
Function of analogue inputs 1/2 0 = analogue input 1 = digital input					



4.033/4.063	<b>AIx physical unit</b>		<b>Unit :</b>	
Relationship to parameter: 4.034/4.064 4.035/4.065	Parameter manual: p.xy	Transfert status: 2	min: 0	Own value (to be entered!)
			max: 10	
			def.: 0	
Selection of different physical values to be displayed.				
0 = %				
1 = bar				
2 = mbar				
3 = psi				
4 = Pa				
5 = m <sup>3</sup> /h				
6 = l/min				
7 = °C				
8 = °F				
9 = m				
10 = mm				

4.034/4.064	<b>AIx physical minimum</b>		<b>Unit :</b>	
Relationship to parameter: 4.033/4.063 4.035/4.065	Parameter manual: p.xy	Transfert status: 2	min: -10 000	Own value (to be entered!)
			max: +10 000	
			def.: 0	
Selection of the lower limit of a physical value to be displayed.				

4.035/4.065	<b>AIx physical maximum</b>		<b>Unit :</b>	
Relationship to parameter: 4.033/4.063 4.034/4.064	Parameter manual: p.xy	Transfert status: 2	min: -10 000	Own value (to be entered!)
			max: +10 000	
			def.: 0	
Selection of the upper limit of a physical value to be displayed.				

### 9.2.6 Digital inputs

4.110/4.113	<b>DIx inverted</b>		<b>Unit : integer</b>	
Relationship to parameter:	Parameter manual: p.xy	Transfert status: 2	min: 0	Own value (to be entered!)
			max: 1	
			def.: 0	
This parameter can be used to invert the digital input.				
0 = disable				
1 = enable				

## 9.2.7 Analogue output

4.100	DIx inverted		Unit : integer	
Relationship to parameter: 4.101 4.102	Parameter manual: p.xy	Transfert status: 2	min: 0	Own value (to be entered!)
			max: 40	
			def.: 5	
<p>Selection of the process value that is output at the analogue output. The standardisation (4.101/4.102) has to be adapted, depending on the selected process value.</p> <p>0 = not assigned / INVEOR soft PLC            1 = intermediate circuit voltage            2 = supply voltage            3 = motor voltage            4 = motor current            5 = frequency feedback            6 = speed measured externally by speed sensor (if available)            7 = current angle or position (if available)            8 = IGBT temperature            9 = internal temperature            10 = analogue input 1            11 = analogue input 2            12 = frequency reference            13 = motor power            14 = torque            15 = field bus            16 = PID reference (as of V3.60)            17 = PID actual value (as of V3.60)</p>				

4.101	AO1 minimum output		Unit :	
Relationship to parameter: 4.100	Parameter manual: p.xy	Transfert status: 2	min: -10 000	Own value (to be entered!)
			max: +10 000	
			def.: 0	
Describes which area is to be broken down into the 0-10 V output voltage or the 0-20 mA output current.				

4.102	AO1 maximum output		Unit :	
Relationship to parameter: 4.100	Parameter manual: p.xy	Transfert status: 2	min: -10 000	Own value (to be entered!)
			max: +10 000	
			def.: 0	
Describes which area is to be broken down into the 0-10 V output voltage or the 0-20 mA output current.				

## 9.2.8 Digital outputs

For digital outputs 1 and 2 (DOx display DO1/DO2)

4.150/4.170	DOx funzione		Unit : integer		
Relationship to parameter: 4.151/4.171 4.152/4.172	Parameter manual: p.xy	Transfert status: 2	min:	0	Own value (to be entered!)
			max:	50	
			def.:	0	
	Selection of the process value to which the output should switch.				
<p>0 = not assigned / INVEOR soft PLC            1 = DC bus voltage            2 = line voltage            3 = motor voltage            4 = motor current            5 = frequency feedback            6 = --            7 = --            8 = IGBT temperature            9 = internal temperature            10= error (NO)            11= inverted error (NC)            12= final release levels            13= digital input 1            14= digital input 2            15= digital input 3            16= digital input 4            17= ready for operation            18= ready            19= operation            20= ready for operation + ready            21= ready for operation + ready + operation            22= ready + operation            23 = motor power            24 = torque 25 = field bus            26 = analogue input 1 (as of V3.60)            27 = analogue input 2 (as of V3.60)            28 = PID reference (as of V3.60)            29 = PID actual value (as of V3.60)            50 = torque</p>					

4.151/4.171	DOx on		Unit :		
Relationship to parameter: 4.150/4.170	Parameter manual: p.xy	Transfert status: 2	min:	-10 000	Own value (to be entered!)
			max:	+10 000	
			def.:	0	
	If the set process value exceeds the switch-on limit, the output is set to 1.				

4.152/4.172	DOx off		Unit :		
Relationship to parameter: 4.150/4.170	Parameter manual: p.xy	Transfert status: 2	min:	-10 000	Own value (to be entered!)
			max:	+10 000	
			def.:	0	
	If the set process parameter falls below the switch-on limit, the output is set to 0.				

## 9.2.9 Relay

For relays 1 and 2 (Rel.x – display Rel. 1/Rel. 2)

4.190/4.210	Rel.x funzione		Unit : integer	
Relationship to parameter: 4.191/4.211 4.1592/4.212	Parameter manual: p.xy	Transfert status: 2	min: 0	Own value (to be entered!)
			max: 50	
			def.: 0	
<p>Selection of the process value to which the output should switch.</p> <p>0 = not assigned / INVEOR soft PLC            1 = DC bus voltage            2 = line voltage            3 = motor voltage            4 = motor current            5 = frequency feedback            6 = –            7 = –            8 = IGBT temperature            9 = internal temperature            10= error (NO)            11= inverted error (NC)            12= final release levels            13= digital input 1            14= digital input 2            15= digital input 3            16= digital input 4            17= ready for operation            18= ready            19= operation            20= ready for operation + ready            21= ready for operation + ready + operation            22= ready + operation            23 = motor power            24 = torque 25 = field bus            26 = analogue input 1 (as of V3.60)            27 = analogue input 2 (as of V3.60)            28 = PID reference (as of V3.60)            29 = PID actual value (as of V3.60)            50 = torque</p>				

4.191/4.211	Rel.x on		Unit :	
Relationship to parameter: 4.190/4.210	Parameter manual: p.xy	Transfert status: 2	min: -10 000	Own value (to be entered!)
			max: +10 000	
			def.: 0	
If the set process value exceeds the switch-on limit, the output is set to 1.				

4.192/4.212	Rel.x off		Unit :	
Relationship to parameter: 4.190/4.210	Parameter manual: p.xy	Transfert status: 2	min: -10 000	Own value (to be entered!)
			max: +10 000	
			def.: 0	
If the set process parameter falls below the switch-on limit, the output is set to 0.				

4.193/4.213	Rel.x on delay		Unit : s	
Relationship to parameter: 4.194/4.214	Parameter manual: p.xy	Transfert status: 2	min: 0	Own value (to be entered!)
			max: 10	
Specifies the length of the switch-on delay.			def.: 0	

4.194/4.214	Rel.x off delay		Unit : s	
Relationship to parameter: 4.193/4.213	Parameter manual: p.xy	Transfert status: 2	min: 0	Own value (to be entered!)
			max: 10	
Specifies the length of the switch-off delay.			def.: 0	

### 9.2.10 External fault

5.010/5.011	External fault 1/2		Unit : integer	
Relationship to parameter: Da 4.110 a 4.113	Parameter manual: p.xy	Transfert status: 2	min: 0	Own value (to be entered!)
			max: 4	
Selection of the source from which an external error can be reported.			def.: 0	
<p>0 = not assigned / INVEOR Soft-PLC  1 = digital input 1  2 = digital input 2  3 = digital input 3  4 = digital input 4</p> <p>If the selected digital input has a high signal, the inverter switches to error no. 23/24 external fault 1/2.</p> <p>Parameters 4.110 to 4.113 DIx inverse can be used to invert the logic of the digital input.</p>				

### 9.2.11 Motor current limit

This function limits the motor current to a parameterised maximum value after a parameterised current-time zone has been reached.

This motor current limit is monitored at application level and thereby limits with relatively low dynamics. This has to be taken into consideration when selecting this function.

The maximum value is determined using the “motor current limit as %” parameter (5.070). This is stated as a percentage and relates to the nominal motor current specified in the “motor current” type plate data (33.031).

The maximum current-time zone is calculated from the product of the “motor current limit in s” parameter (5.071) and the fixed overcurrent of 50% of the required motor current limit.

As soon as this current-time zone is exceeded, the motor current is restricted to the limit value by reducing the rotation speed. If the output current of the drive control exceeds the motor current (parameter 33.031) multiplied by the set limit as % (parameter 5.070) for the set time (parameter 5.071), the speed of the motor is reduced until the output current is below the set limit. This reduction is undertaken by a PI controller that operates depending on the current difference.

The entire function can be deactivated by setting the “motor current limit as %” parameter (5.070) to zero.

5.070	Motor current limit		Unit : %	
Relationship to parameter: 5.071 33.031	Parameter manual: p.xy	Transfert status: 2	min: 0	Own value (to be entered!)
			max: 250	
			def.: 0	
0 = disable				

5.071	Motor current limit		Unit : %	
Relationship to parameter: 5.070 33.031	Parameter manual: p.xy	Transfert status: 2	min: 0	Own value (to be entered!)
			max: 100	
			def.: 0	

5.075	Gearbox factor		Unit :	
Relationship to parameter: 33.034	Parameter manual: p.xy	Transfert status: 2	min: 0	Own value (to be entered!)
			max: 1000	
			def.: 0	
A gearbox factor can be set here. The mechanical speed display can be adjusted using the gearbox factor.				

### 9.2.12 Stall detection

5.080	Stall detection		Unit : integer	
Relationship to parameter: 5.081	Parameter manual: p.xy	Transfert status: 2	min: 0	Own value (to be entered!)
			max: 1	
def.: 0				
This parameter can be used to activate stall detection. 0 = disable 1 = enable				

5.081	Blocking time		Unit : s	
Relationship to parameter: 5.080	Parameter manual: p.xy	Transfert status: 2	min: 0	Own value (to be entered!)
			max: 50	
def.: 0				
Indicates the time after which a blockage is detected.				

5.090	Parameter set change		Unit : integer	
Relationship to parameter:	Parameter manual: p.xy	Transfert status: 2	min: 0	Own value (to be entered!)
			max: 7	
def.: 0				
Selection of active data set.  0 = not assigned 1 = data set 1 active 2 = data set 2 active 3 = digital input 1 4 = digital input 2 5 = digital input 3 6 = digital input 4 7 = INVEOR soft PLC  The 2nd data set is only displayed in the PC software when this parameter is $\leq 0$ . The values of the data set currently selected are always displayed in the MMI.				

## 9.3 Performance parameters

### 9.3.1 Motor data

33.001	Type of motor		Unit : integer	
Relationship to parameter: 34.010	Parameter manual: p.xy	Transfert status: 2	min: 1	Own value (to be entered!)
			max: 2	
			def.: 1	
<p>Selecting the type of motor</p> <p>1 = asynchronous motor 2 = synchronous motor</p> <p>The parameters are shown depending on the type of motor selected. The type of control (parameter 34.010) must also be selected.</p>				

33.015	R optimisation		Unit : %	
Relationship to parameter: 34.010	Parameter manual: p.xy	Transfert status: 2	min: 0	Own value (to be entered!)
			max: 200	
			def.: 100	
If necessary, this parameter can be used to optimise the start-up behaviour.				

33.031	Motor current		Unit : A	
Relationship to parameter: 5.070	Parameter manual: p.xy	Transfert status: 2	min: 0	Own value (to be entered!)
			max: 150	
			def.: 0	
This is used to set the nominal motor current $I_{M,N}$ for either the star or triangle connection.				

33.032	Motor power		Unit : W	
Relationship to parameter:	Parameter manual: p.xy	Transfert status: 2	min: 0	Own value (to be entered!)
			max: 55 000	
			def.: 0	
A performance value [W] $P_{M,N}$ has to be set here that corresponds to the motor power.				

33.034	Motor speed		Unit : rpm	
Relationship to parameter: 34.120 5.075	Parameter manual: p.xy	Transfert status: 2	min: 0	Own value (to be entered!)
			max: 10 000	
			def.: 0	
The value from the motor's type plate data has to be entered here for the nominal motor rotation speed $n_{M,N}$ .				

33.035	Motor speed		Unit : Hz	
Relationship to parameter: 34.120 5.075	Parameter manual: p.xy	Transfert status: 2	min: 40	Own value (to be entered!)
			max: 100	
			def.: 0	
This is where the nominal motor frequency $f_{M,N}$ is set.				



33.050	Resistenza statorica		Unit : Ohm	
Relationship to parameter:	Parameter manual: p.xy	Transfert status: 2	min: 0	Own value (to be entered!)
			max: 30	
			def.: 0,001	
The stator resistance can be optimised here, if the automatically determined value (motor identification) is insufficient.				

33.105	Leakage inductance		Unit : H	
Relationship to parameter:	Parameter manual: p.xy	Transfert status: 2	min: 0	Own value (to be entered!)
			max: 100	
			def.: 0	
Only for asynchronous motors. Here the leakage inductance can be optimised if the automatically calculated value (of motor identification) isn't sufficient.				

33.110	Motor voltage		Unit : V	
Relationship to parameter:	Parameter manual: p.xy	Transfert status: 2	min: 0	Own value (to be entered!)
			max: 680	
			def.: 0	
Only for asynchronous motors. This is used to set the nominal motor voltage $U_{M,N}$ for either the star or triangle connection.				

33.111	Motor cos phi		Unit : 1	
Relationship to parameter:	Parameter manual: p.xy	Transfert status: 2	min: 0,5	Own value (to be entered!)
			max: 1	
			def.: 0	
Only for asynchronous motors. The value from the motor's type plate data has to be entered here for the power factor cos phi.				

33.200	Stator inductance		Unit : H	
Relationship to parameter:	Parameter manual: p.xy	Transfert status: 2	min: 0	Own value (to be entered!)
			max: 100	
			def.: 0	
For synchronous motors only. The stator inductance can be optimised here if the automatically determined value (motor identification) is insufficient.				

33.201	Nominal flux		Unit : mVs	
Relationship to parameter:	Parameter manual: p.xy	Transfert status: 2	min: 0	Own value (to be entered!)
			max: 5 000	
			def.: 0	
For synchronous motors only. The nominal flux can be optimised here if the automatically determined value (motor identification) is insufficient.				

### 9.3.2 I<sup>2</sup>T control

33.010	I <sup>2</sup> T fact. motor		Unit : %	
Relationship to parameter: 33.031 33.011	Parameter manual: p.xy	Transfert status: 2	min: 0	Own value (to be entered!)
			max: 1 000	
def.: 100				
The percentage current threshold (in relation to motor current 33.031) at the start of integration can be set here.				

33.011	I <sup>2</sup> T time		Unit : s	
Relationship to parameter: 33.010	Parameter manual: p.xy	Transfert status: 2	min: 0	Own value (to be entered!)
			max: 1 200	
			def.: 25	
Time after which the drive control switches off with I <sup>2</sup> T.				

33.138	Holding current time		Unit : s	
Relationship to parameter: 33.010	Parameter manual: p.xy	Transfert status: 2	min: 0	Own value (to be entered!)
			max: 128 000	
			def.: 2	
Only for asynchronous motors. This is the time during which the drive is held at continuous current after the brake ramp has been completed.				

### 9.3.3 Switching frequency

The internal switching frequency (clocking frequency) can be changed in order to control the power element. A high setting reduces noise in the motor but increases EMC emissions and losses in the drive control.

34.030	Switching		Unit : Hz	
Relationship to parameter:	Parameter manual: p.xy	Transfert status: 2	min: 1	Own value (to be entered!)
			max: 4	
			def.: 2	
			Selection of the switching frequency for the inverter	
1 = 16 kHz				
2 = 8 kHz				
4 = 4 kHz				

### 9.3.4 Controller data

34.010	Control method		Unit : integer	
Relationship to parameter: 33.001 34.011	Parameter manual: p.xy	Transfert status: 2	min: 100	Own value (to be entered!)
			max: 201	
			def.: 100	
Selection of the type of control.  100 = open-loop asynchronous motor 101 = closed-loop asynchronous motor 200 = open-loop synchronous motor 201 = closed-loop synchronous motor				

34.011	Type of encoder		Unit : integer	
Relationship to parameter: 34.010 34.012 34.013	Parameter manual: p.xy	Transfert status: 2	min: 0	Own value (to be entered!)
			max: 2	
			def.: 0	
Selection of the type of sensor 0 = inactive 1 = TTL sensor 2 = HTL sensor   <b>WARNING</b> When selecting the HTL sensor, 24V is transmitted via the interface. If using a TTL sensor, this could result in damage to the sensor.				

34.012	Encoder line count		Unit : integer	
Relationship to parameter: 34.010 34.011 34.013	Parameter manual: p.xy	Transfert status: 2	min: 0	Own value (to be entered!)
			max: 10 000	
			def.: 1024	
Selection of the line count of the sensor used.				

34.013	Encoder offset		Unit : °	
Relationship to parameter: 34.010 34.011 34.012	Parameter manual: p.xy	Transfert status: 2	min: 0	Own value (to be entered!)
			max: 360	
			def.: 0	
An encoder offset for the sensor can be set here.				

34.021	Flying restart		Unit :	
Relationship to parameter:	Parameter manual: p.xy	Transfert status: 1	min: 0	Own value (to be entered!)
			max: 1	
			def.: 1	
This parameter is used to activate the capture function. 0 = disable 1 = enable				

<b>34.090</b>	<b>Speed control <math>K_p</math></b>		<b>Unit : mA/rad/s</b>	
Relationship to parameter:	Parameter manual: p.xy	Transfert status: 2	min: 0	Own value (to be entered!)
			max: 10 000	
			def.: 150	
	The control boost of the speed control can be optimised here, if the automatically determined results (of the motor identification) are insufficient.			

<b>34.091</b>	<b>Speed control <math>T_n</math></b>		<b>Unit : s</b>	
Relationship to parameter:	Parameter manual: p.xy	Transfert status: 2	min: 0	Own value (to be entered!)
			max: 10	
			def.: 4	
	The reset time of the speed control can be optimised here, if the automatically determined results (of the motor identification) are insufficient.			

<b>34.110</b>	<b>Slip trimmer</b>		<b>Unit :</b>	
Relationship to parameter: 33.034	Parameter manual: p.xy	Transfert status: 2	min: 0	Own value (to be entered!)
			max: 1	
			def.: 1	
	<p>Only for asynchronous motors. This parameter can be used to optimise or deactivate slippage compensation.</p> <p>0 = disable (performance as on the grid) 1 = compensation for slippage.</p>			

<b>34.130</b>	<b>Voltage control reserve</b>		<b>Unit : integer</b>	
Relationship to parameter: 34.121	Parameter manual: p.xy	Transfert status: 2	min: 0	Own value (to be entered!)
			max: 1	
			def.: 0	
	<p>Only for asynchronous motors. This parameter can be used to adjust voltage output.</p>			

### 9.3.5 Quadratic characteristic

<b>34.120</b>	<b>Quadratic characteristic</b>		<b>Unit : integer</b>	
Relationship to parameter: 34.121	Parameter manual: p.xy	Transfert status: 2	min: 0	Own value (to be entered!)
			max: 2	
			def.: 0,95	
	<p>Only for asynchronous motors. The quadratic characteristic curve function can be activated here.</p> <p>0 = disable 1 = enable</p>			

<b>34.121</b>	<b>Flux compensation</b>		<b>Unit : %</b>	
Relationship to parameter: 33.120	Parameter manual: p.xy	Transfert status: 2	min: 0	Own value (to be entered!)
			max: 100	
			def.: 50	
	<p>Only for asynchronous motors. The percentage by which the flux is to be reduced can be set here. An overvoltage shutdown can occur if there are any major changes in operation.</p>			

### 9.3.6 Synchronous motor controller data

34.225	<b>Quadratic characteristic</b>		Unit : integer	
Relationship to parameter:	Parameter manual: p.xy	Transfert status: 2	min: 0	Own value (to be entered!)
			max: 1	
	def.: 0			
	For synchronous motors only.  0 = disable, the motor cannot be run in the field weakening. 1 = enable, the motor can be placed in the field weakening until the inverter has reached its current limit or the maximum permissible electromotive force.			

34.226	<b>Starting current</b>		Unit : %	
Relationship to parameter: 34.227	Parameter manual: p.xy	Transfert status: 2	min: 5	Own value (to be entered!)
			max: 1 000	
	def.: 25			
	For synchronous motors only. Here the current which was stamped in the motor before starting the control can be adjusted. As % of nominal motor current.			

34.227	<b>Init time</b>		Unit : s	
Relationship to parameter: 34.226	Parameter manual: p.xy	Transfert status: 2	min: 0	Own value (to be entered!)
			max: 100	
	def.: 0,25			
	For synchronous motors only. Here the time during which the start up current 34.226 is stamped can be set.			

34.228-34.230	<b>Init time</b>		Unit : integer	
Relationship to parameter:	Parameter manual: p.xy	Transfert status: 2	min: 0	Own value (to be entered!)
			max: 1	
	def.: 0			
	For synchronous motors only.  By changing the startup procedure to “Controlled”, higher starting torques can be achieved. 0 = regulated, the inverter switches directly to the controller after the stamping phase. 1 = controlled, after the stamping phase the rotation field is increased by the control with start ramp 34.229 up to start frequency 34.230, then switched to the controller.			

### 9.3.7 Field bus

<b>6.060</b>	<b>Set field bus address</b>		<b>Unit : integer</b>	
Relationship to parameter: 6.061, 6.062	Parameter manual: p.xy	Transfert status: 2	min: 0	Own value (to be entered!)
			max: 127	
		def.: 0		
For synchronous motors only. Here the time during which the start up current 34.226 is stamped can be set.				

<b>6.061</b>	<b>Set field bus baud rate</b>		<b>Unit : integer</b>	
Relationship to parameter: 6.060, 6.062	Parameter manual: p.xy	Transfert status: 2	min: 0	Own value (to be entered!)
			max: 8	
		def.: 2		
CanOpen applies: 0 = 1 MBit, 2 = 500 kBit, 3 = 250 kBit, 4 = 125 kBit, 6 = 50 kBit, 7 = 20 kBit, 8 = 10 kBit				

<b>6.062</b>	<b>Set bus time-out</b>		<b>Unit : integer</b>	
Relationship to parameter: 1.130	Parameter manual: p.xy	Transfert status: 2	min: 0	Own value (to be entered!)
			max: 100	
		def.: 5		
Bus time-out in seconds. The time-out counter is activated if the bus was selected for the motor current's target value source and a target value other than "0" is specified. The time-out is deactivated when 0 => bus time-out.				

### 9.3.7 MODBUS parameters

Number parameter	Name parameter	Description	Values
6.050	SAS/MODBUS Adr	address of the Modbus slave	1...247
6.051	SAS/MODBUS Baudr	Baudrate	0=9600, 1=19200, 2=38400, 3 = 57600, 4=115200, 5=600, 6=1200, 7=2400, 8=4800
6.062	Bus Timeout	The bus timeout specifies the maximum temporal distance between two consecutive protocols. A value of {0} [s] switches it off permanently	0 s (to) ... 100 s
6.064	RS 485 bus type	The field bus at connector 2 is configured here	0 = SAS / SPF 1 = Modbus RTU/ SPF
6.065	MODBUS Config	Setting of parity, endianness, stop bits, Num. Bits and data access width. The data access width to a parameter or process value can be 16 bit or 32 bit	0 = 8 Bits, No Parity, 2 Stop bit, 16 Bit, Big Endian 1 = 8 Bits, No Parity, 1 Stop bit, 16 Bit, Big Endian 2 = 8 Bits, Even Parity, 1 Stop bit, 16 Bit, Big Endian 3 = 8 Bits, Odd Parity, 1 Stop bit, 16 Bit, Big Endian 4 = 8 Bits, No Parity, 2 Stop bit, 32 Bit, Big Endian 5 = 8 Bits, No Parity, 1 Stop bit, 32, Bit, Big Endian 6 = 8 Bits, Even Parity, 1 Stop bit, 32 Bit, Big Endian 7 = 8 Bits, Odd Parity, 1 Stop bit, 32 Bit, Big Endian

For more details see the manual on the Modbus communication Modbus.

## 10 Accessories

### 10.1 ESV TST MMI

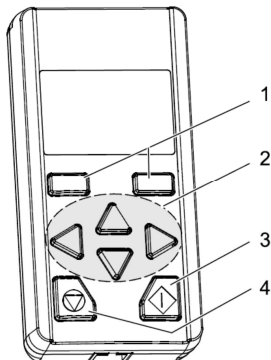
	<b>Key</b>	<b>Function</b>
	1	Buttons confirmation up/down, increase/decrease
	2	up / down to select parameters Cursor navigation left / right
	3	Run
4	Stop	

	<b>Key</b>	<b>Function</b>
	1	INVEOR drive control
	2	INVEOR MMI manual control unit
	3	RJ11 socket
	4	Communication cable
5	M12 socket	

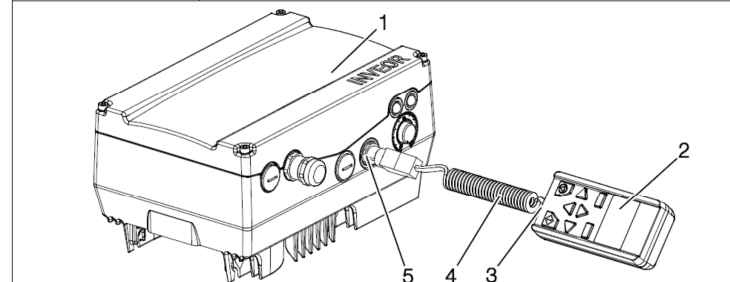

The keyboard is used to program and possibly for the running and stopping but in environments IP20.

The keyboard MMI addition to the display function of the parameters of ESV and the change of the single parameters is able to copy the programming of an ESV on another (charging all the parameters on its Unit of internal memory)

### 10.2 INTERFACE CABLE PC USB – MMI

The cable is used to connect between the PC (using USB) connector and the MMI ESV.





### 10.3 Cable and connector for PROFIBUS communication

The Profibus option (I / O = P) has an extra connector 5-pin profibus trade round 5 pin M12.

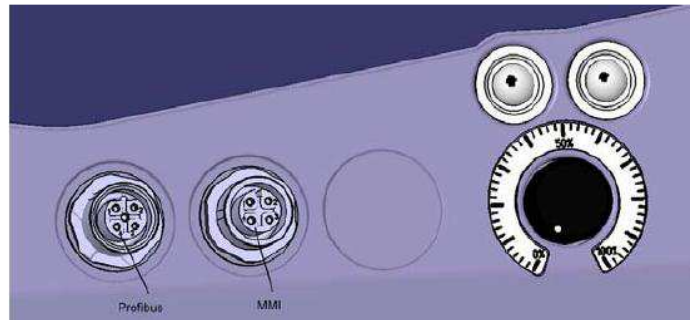

	<b>Pin Device</b>	<b>Signal</b>
	1	+5V DC
	2	RxD/TxD-N / A-line (green)
	3	ground
	4	RxD/TxD-P / B-line (red)
	5	not wired
	Housing	Shielding

The ESV is obviously compatible with the Y-splitter commercial.

Fieldbus Y-piece, complete shielded 12MBaud

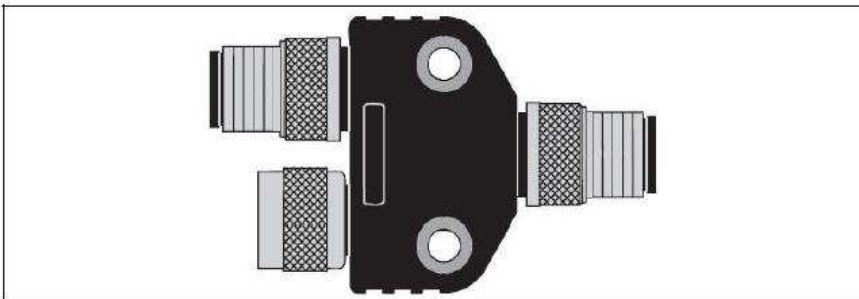

Producer: TURCK, Type VB2-FSW-FKW-FSW-45, Art.-No.: 6996009

Producer: BECKHOFF Art.-No.: ZS1000-2600

Producer: ESCHA Art.-No.: 8011228

And termination resistor on commerce

Passive resistor (male connector)



Producer: TURCK, Type RSS4.5-PDP-TR, Art.-No.: 6601590

Producer: BECKHOFF Art.-No.: ZS1000-1610

Producer: ESCHA Art.-No.: 8043520