

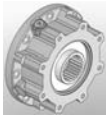

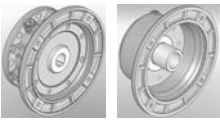



**PRÉDISPOSITION FIXATION MOTEUR**  
**PREDISPOSICIONES CONEXIÓN MOTOR**  
**PREPARAÇÕES ENGATE MOTOR**

**D**

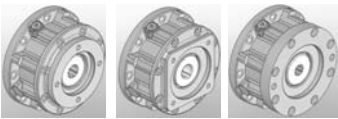
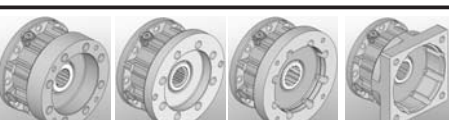
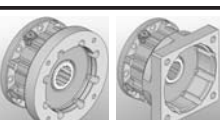
	<b>EU</b>	<b>D2</b>
	<b>IEC</b>	<b>D3</b>
	<b>Z.</b> <b>Z0.</b> <b>Z1.</b> <b>Z2.</b>	<b>D6</b>
	<b>I</b> <b>CB</b> <b>DB</b> <b>BA</b> <b>CA</b> <b>DA</b> <b>EA</b>	<b>D8</b>
	<b>I</b> <b>GD</b> <b>FB</b> <b>GC</b> <b>HB</b> <b>FA</b> <b>GAB</b> <b>HA</b>	<b>D12</b>
	<b>I</b> <b>LB</b> <b>JA</b> <b>KB</b> <b>LA</b>	<b>D16</b>
	<b>I</b> <b>MA</b> <b>NA</b>	<b>D20</b>
	<b>I</b> <b>OA</b> <b>PA</b> <b>QA</b>	<b>D22</b>
	<b>ECE</b>	<b>D28</b>
	<b>ECR</b>	<b>D30</b>
	<b>EX.</b>	<b>D42</b>

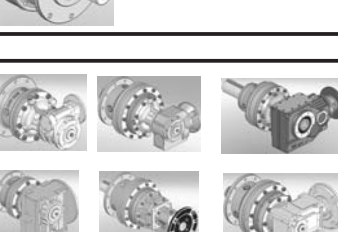

**Input Shaft - PAM**  
EU - universal

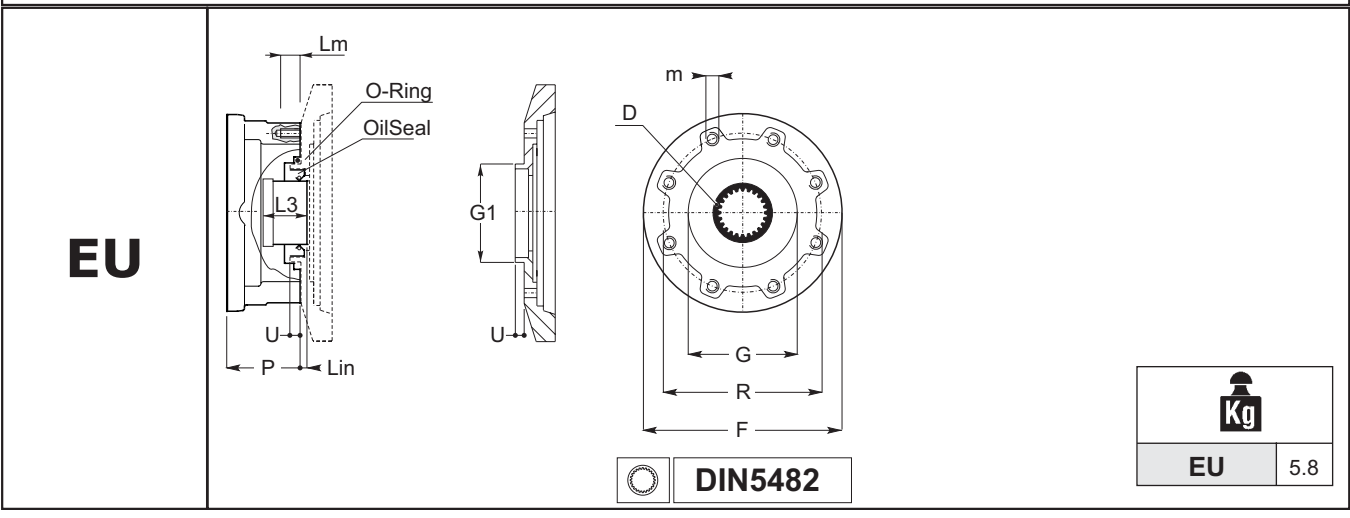

D	F	R	G	U <sub>max</sub>	L <sub>IN</sub>	L <sub>3</sub>	m	L <sub>m</sub>	O <sub>Ring</sub>	OilSeal
DIN 5482 50 x 45	186-244 295-350	+/- 0.1 150	H7 - g6 95	6	4	38	M10	20	94.92 x 2.62	60x80x7.5

	EX1			EX2 EXB2			EX3 EXB3			EX4 EXB4						
	EX 101⇒1001			EX 102⇒6002			EX 103⇒16003			EX 104⇒45004						
				EXB 102⇒3002			EX 103⇒10003			EXB 104⇒31004						
10	101			102			103			104						
20	201			202			203			204						
25	251			252			253			254						
30		301		302			303			304						
35		351		352			353			354						
40				402			403			404						
50		501		502			503			504						
70		701		702			703			704						
80			801		802		803			804						
90					902		903			904						
95					952		953			954						
100			1001		1002		1003			1004						
150				1501	1502		1503			1504						
180					1802		1803			1804						
200				2001	2002		2003			2004						
250						2502		2503		2504						
280						2802		2803		2804						
300						3002		3003		3004						
350						3502		3503		3504						
360							3602	3603		3604						
420							4202	4203		4204						
600							6002	6003		6004						
650								6503		6504						
800								8003		8004						
850								8503		8504						
1000								10003		10004						
1200								12003		12004						
1500								15003		15004						
1600									16003	16004						
2000											20004					
2500											25004					
2600											26004					
3000											30004					
3100											31004					
3200											32004					
3700											37004					
4500												45004				
<b>EU</b>	67	75	83	90.5	67	75	83	90.5	67	75	83	90.5	67	75	83	90.5

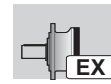

# Input Shaft - PAM

IEC - electric motor

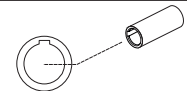

**IEC**

Size  
IEC ≤ 200    IEC ≥ 225

Kg	
71-80-90	8
100-112	10
132	12
160-180	19
200	25
225	30
250-280	51

	D	F	R	G	U	V	Z	L <sub>IN</sub>	L <sub>3</sub>	b	t
	F7		+/-0,1	F8 G6						H7	+0,1 +0,2
<b>63</b>	11	140	115	95	10	M8	16	5,5	25	4	12,8
<b>71</b>	14	160	130	110	10	M8	16	5,5	32	5	16,3
<b>80</b>	19	200	165	130	5	M10	14	5,5	52	6	21,8
<b>90</b>	24	200	165	130	5	M10	14	5,5	52	8	27,3
<b>100</b>	28	250	215	180	5	M12	14	10,5	61	8	31,3
<b>112</b>	28	250	215	180	5	M12	14	10,5	61	8	31,3
<b>132</b>	38	300	265	230	5	M12	14	10,5	82	10	41,3
<b>160</b>	42	350	300	250	6	M16	18	8,5 - 24,5	111	12	45,3
<b>180</b>	48	350	300	250	6	M16	18	8,5 - 24,5	111	14	51,8
<b>160</b>	42	350	300	250	6	M16	18	24,5	111	12	45,3
<b>180</b>	48	350	300	250	6	M16	18	24,5	111	14	51,8
<b>200</b>	55	400	350	300	6	M16	22	8,5	111	16	59,3
<b>225</b>	60	450	400	350	6	M16	20	8,5	143	18	64,4
<b>250</b>	65	550	500	450	6	M16	21	8,5	145	18	69,4
<b>280</b>	75	550	500	450	6	M16	21	8,5	145	20	79,9

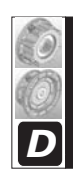



	EX1				EX2				EX3				EX4			
10	101				102				103				104			
20	201				202				203				204			
25	251				252				253				254			
30		301			302				303				304			
35		351			352				353				354			
40					402				403				404			
50		501			502				503				504			
70		701			702				703				704			
80			801		802				803				804			
90					902				903				904			
95					952				953				954			
100			1001		1002				1003				1004			
150				1501	1502				1503				1504			
180					1802				1803				1804			
200				2001	2002				2003				2004			
250						2502			2503				2504			
280						2802			2803				2804			
300						3002			3003				3004			
350						3502			3503				3504			
360							3602		3603				3604			
420							4202		4203				4204			
600							6002		6003				6004			
650										6503			6504			
800										8003			8004			
850										8503			8504			
1000										10003			10004			
1200										12003			12004			
1500										15003			15004			
1600											16003		16004			
2000															20004	
2500															25004	
2600															26004	
3000															30004	
3100															31004	
3200															32004	
3700															37004	
4500																45004
5500																
6800																
7500																
8000																

63	83	91	99		83	91	99		83	91	99		83	91	99	
71	83	91	99		83	91	99		83	91	99		83	91	99	
80	83	91	99		83	91	99		83	91	99		83	91	99	
90	83	91	99		83	91	99		83	91	99		83	91	99	
100	91	99	107		91	99	107		91	99	107		91	99	107	
112	91	99	107		91	99	107		91	99	107		91	99	107	
132	112	120	128		112	120	128		112	120	128		112	120	128	
160	146	170	167		146	170	167		146	170	167		146	170	167	
180	146	170	167		146	170	167		146	170	167		146	170	167	
200		154	165	175		154	165	175		154	165	175		154	165	175
225		189	188.5	205		189	188.5	205		189	188.5	205		189	188.5	205
250			188.5	205			188.5	205			188.5	205			188.5	205
280			188.5	205			188.5	205			188.5	205			188.5	205

P - [mm]



	EXB2				EXB3				EXB4				
10	102				103				104				
20	202				203				204				
25	252				253				254				
30	302				303				304				
35	352				353				354				
40					403				404				
50		502			503				504				
70		702			703				704				
80			802		803				804				
90					903				904				
95					953				954				
100			1002			1003			1004				
150				1502		1503			1504				
180				-		1803			1804				
200				2002		2003			2004				
250					2502			2503		2504			
280								2803			2804		
300					3002			3003			3004		
350								3503			3504		
360									3603		3604		
420									4203		4204		
600									6003		6004		
650								6503			6504		
800								8003			8004		
850								8503			8504		
1000								10003			10004		
1200											12004		
1500											15004		
1600												16004	
2000													20004
2500													25004
2600													26004
3000													30004
3100													31004
3200													32004
3700													
4500													
5500													
6800													
7500													
8000													

63					99					99					99
71	52				99	52				99	52				99
80	52	52			99	52	52			99	52	52			99
90	52	52	47		99	52	52	47		99	52	52	47		99
100	60	60	55		107	60	60	55		107	60	60	55		107
112	60	60	55		107	60	60	55		107	60	60	55		107
132	112	81	76	120	128	112	81	76	120	128	112	81	76	120	128
160	146	146	170	170	167	146	146	170	170	167	146	146	170	170	167
180	146	146	170	170	167	146	146	170	170	167	146	146	170	170	167
200			154	154	165			154	154	165			154	154	165
225			189	189	188.5			189	189	188.5			189	189	188.5
250					188.5					188.5					188.5
280					188.5					188.5					188.5

P - [mm]

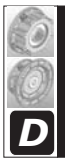

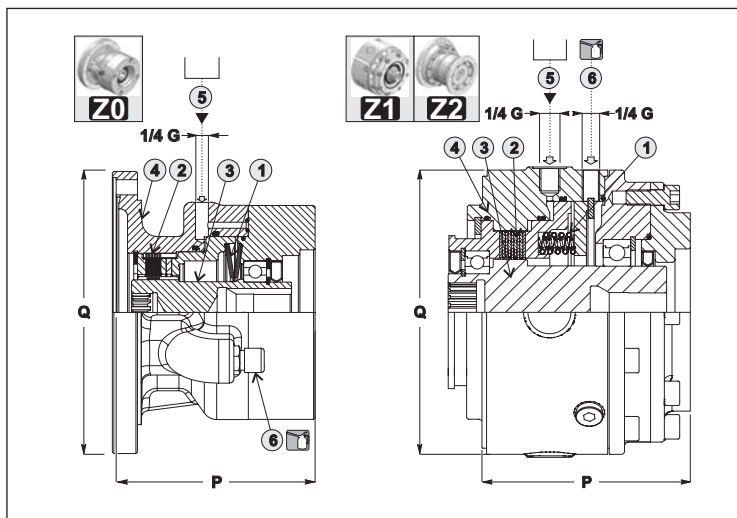

		A	B	C	D	E	F	G	H	Q	$\uparrow$ Kg
<b>Z0</b>	$T_{RF}$	60	100	160	200	280	330	430	520	186	12
	$P_{Af}$	10	16	16	20	20	24	24	29		
<b>Z1.</b>	$T_{RF}$	90	140	240	300	430	550	—	—	186	26
	$P_{Af}$	8.5	13	11	15	20	25	—	—		
<b>Z2.</b>	$T_{RF}$	400	650	800	1000	1250	1500	1700	—	244	30
	$P_{Af}$	25	41	25	32	30	36	41	—		
$P_{max} = 310$											
$P_{INF}$ [bar] = Pression entrée-installation hydraulique/Presión entrada-sistema hidráulico/Pressão de entrada-sistema hidráulico $P_{Af}$ [bar] = Pression ouverture frein/Presión apertura freno/Pressão de abertura do freio $P_c$ [bar] = Contrepression dans l'installation hydraulique/Contrapresión en el sistema hidráulico/Contrapressão no sistema hidráulico $P_{max}$ [bar] = Pression max./Presión max./Pressão máx. $T_{RF}$ [Nm] = Couple moyen Statique/Par promedio Estático/Binário médio Estático											

- 1 - Ressorts / Muelles / Molas
- 2 - Disques à Lamelles / Discos de Láminas / Discos de Láminas
- 3 - Arbre d'entrée / Eje entrada / Eixo entrada
- 4 - Carcasse Frein / Carcasa Freno / Carcaça Freio
- 5 - Attache Commande Frein / Conexión Mando Freno / Engate Comando Freio
- 6 - Bouchon de remplissage et de purge huile / Tapón Carga y Respiradero Aceite / Tampa de Carga e Respiro do Óleo

**1.0 - Secteur d'application**

Le frein est à employer uniquement comme frein de stationnement et non pour les freinages dynamiques.

**1.0 - Campo aplicación**

Se debe emplear el freno solo como freno de estacionamiento y no para efectuar frenados dinámicos.

**1.0 - Campo de aplicação**

O freio só deve ser usado como freio de estacionamento e não para efetuar frenagens dinâmicas.

**2.0 - Principe de fonctionnement du frein**

Le fonctionnement du frein est du type négatif et suit les modalités suivantes :

**2.1 - Condition 1- Pression  $P_{INF} = 0$**

Les ressorts (composant 1) exercent une poussée sur le couple de disques à lamelles (composant 2).

Certains disques sont solidaires avec un élément mobile (composant 3) et d'autres avec un élément fixe (composant 4). Dans cette condition opérationnelle un couple  $T_{RF}$  avec un niveau de précision de la valeur de  $\pm 10\%$  (Z1-Z2) et  $\pm 18\%$  Z0 se crée sur la douille du réducteur (composant 3).

**2.2 - Condition 2 - Pression  $P_{INF} = P_{Af}$**

Si une pression  $P_{INF}$  égale à la pression d'ouverture  $P_{Af}$  est exercée à travers l'attache commande du frein (composant 5), la valeur du couple résistant TRF est égale à zéro permettant la rotation libre de la douille du réducteur.

**2.3 - Condition 3 - Contre-pression présente dans l'installation hydraulique rotation libre  $P_c \neq 0$ .**

Ces performances ( $T_{RF}$ ) sont toujours calculées avec la contre-pression égale à zéro. Dans le cas contraire le couple freinant est réduit en pourcentage du point de vue du rapport contre-pression/pression ouverture frein.

Rappelons que les grandes vitesses de rotation ou les fonctionnements prolongés avec l'axe vertical peuvent générer des augmentations de température importantes : dans ces cas voir Section A.

**2.0 - Principio de funcionamiento freno**

El funcionamiento del freno es de tipo negativo con las siguientes modalidades operativas:

**2.1 - Condición 1 - Presión  $P_{INF} = 0$**

Los muelles (detalle 1) ejercen un empuje en los pares de discos de láminas (componente 2). Algunos discos son solidarios al elemento móvil (componente 3) y otros al elemento fijo (componente 4). En esta condición operativa se genera, en el manguito reductor (componente 3), un par  $T_{RF}$  con nivel de precisión del valor de  $\pm 10\%$  (Z1-Z2) y  $\pm 18\%$  Z0.

**2.2 - Condición 2 - Presión  $P_{INF} = P_{Af}$**

Si mediante la conexión mando freno (componente 5), se introduce una presión  $P_{INF}$  igual a la presión de apertura  $P_{Af}$ , el valor del par resistente TRF es igual a cero y permite la libre rotación del manguito del reductor.

**2.3 - Contrapresión presente en el sistema hidráulico  $P_c \neq 0$**

Dichas prestaciones ( $T_{RF}$ ) se calculan siempre con contrapresión igual a cero. De lo contrario, el par frenante se reduce en porcentaje en relación contrapresión/Presión apertura freno.

Recordamos que altas velocidades de rotación o funcionamientos prolongados con eje vertical pueden causar aumentos elevados de temperatura: en estos casos consultar la Sección A.

**2.0 - Princípio de funcionamento do freio**

O funcionamento do freio é do tipo negativo com as seguintes modalidades operacionais:

**2.1 - Condição 1 - Pressão  $P_{INF} = 0$**

As molas (detalhe 1) exercem um impulso nos pares de discos de lâminas (componente 2). Alguns discos são fixos com elemento móvel (componente 3) e discos fixos com elemento fixo (componente 4). Nesta condição operacional gera-se na manga do reductor (componente 3) um binário  $T_{RF}$  com nível de precisão do valor de  $\pm 10\%$  (Z1-Z2) e  $\pm 18\%$  Z0.

**2.2 - Condição 2 - Pressão  $P_{INF} = P_{Af}$**

Caso através do engate do comando do freio (componente 5), seja inserida uma pressão  $P_{INF}$  igual à pressão de abertura  $P_{Af}$ , o valor do binário resistente TRF é igual a zero consentindo a livre rotação da manga do reductor.

**2.3 - Condição 3 - Contrapressão presente no sistema hidráulico  $P_c \neq 0$ .**

Tais desempenhos ( $T_{RF}$ ) são sempre calculados com contrapressão igual a zero. Em caso contrário, o binário de frenagem é percentualmente reduzido na relação contrapressão/Pressão de abertura do freio.

Lembramos que altas velocidades de rotação, ou prolongados funcionamentos com eixo vertical, podem gerar elevados aumentos de temperatura: nestes casos, consultar a Secção A.

	F	R	G	U	V	Z	$L_{TN}$	L3	b	t
<b>Z0</b>	LOOK AT									
<b>Z1</b>	D8-D10-D12-D14-D16-D18-D19-D20-D21-D22-D23-D24-D25-D28-D29									
<b>Z2</b>										



Z.	EX1			EX2 EXB2			EX3 EXB3			EX4 EXB4		
	EX 101 → 2001			EX 102 → 4202			EX 103 → 16003			EX 104 → 45004		
				EXB 102 → 3002			EXB 103 → 10003			EXB 104 → 31004		
10	101			102			103			104		
20	201			202			203			204		
25	251			252			253			254		
30		301		302			303			304		
35		351		352			353			354		
40				402			403			404		
50		501		502			503			504		
70		701		702			703			704		
80			801		802		803			804		
90					902		903			904		
95					952		953			954		
100			1001		1002		1003			1004		
150				1501			1503			1504		
180					1802		1803			1804		
200				2001	2002		2003			2004		
250						2502		2503		2504		
280						2802		2803		2804		
300						3002		3003		3004		
350						3502		3503		3504		
360							3602	3603		3604		
420							4202	4203		4204		
600							6002	6003		6004		
650								6503			6504	
800								8003			8004	
850								8503			8504	
1000								10003			10004	
1200								12003			12004	
1500								15003			15004	
1600									16003		16004	
2000												20004
2500												25004
2600												26004
3000												30004
3100												31004
3200												32004
3700												37004
4500												45004
<b>Z0</b>	<b>Z0.1</b>			<b>Z0.1</b>			<b>Z0.1</b>			<b>Z0.1</b>		
CA 04	131			131			131			131		
CA 05	131			131			131			131		
CA 09	131			131			131			131		
<b>Z1</b>	<b>Z1.1</b>	<b>Z1.2</b>		<b>Z1.1</b>	<b>Z1.2</b>		<b>Z1.1</b>	<b>Z1.2</b>		<b>Z1.1</b>	<b>Z1.2</b>	
CA 04	166	174.5		166	174.5		166	174.5		166	174.5	
CA 09	166	174.5		166	174.5		166	174.5		166	174.5	
CB 07	178	186.5		178	186.5		178	186.5		178	186.5	
DA 11	160	168.5		160	168.5		160	168.5		160	168.5	
DB 22	180	188.5		180	188.5		180	188.5		180	188.5	
FA 13	186	194.5		186	194.5		186	194.5		186	194.5	
FA 22	186	194.5		186	194.5		186	194.5		186	194.5	
FA 23	186	194.5		186	194.5		186	194.5		186	194.5	
FA 24	186	194.5		186	194.5		186	194.5		186	194.5	
FA 28	186	194.5		186	194.5		186	194.5		186	194.5	
FB 08	226	234.5		226	234.5		226	234.5		226	234.5	
PA 29	168	176.5		168	176.5		168	176.5		168	176.5	
ECE 6	165	173.5		165	173.5		165	176.5		165	176.5	
<b>Z2</b>		<b>Z2.2</b>	<b>Z2.3</b>	<b>Z2.4</b>		<b>Z2.2</b>	<b>Z2.3</b>	<b>Z2.4</b>		<b>Z2.2</b>	<b>Z2.3</b>	<b>Z2.4</b>
FA13		248	237	245		248	237	245		248	237	245
FA24		248	237	245		248	237	245		248	237	245
HB24		257	246	254		257	246	254		257	246	254
KB24		265	254	262		265	254	262		265	254	262
LA25		264	253	261		264	253	261		264	253	261
OA31		244	233	241		244	233	241		244	233	241
ECE 7		*	*	*		*	*	*		*	*	*

P - [mm] \*Contacter notre bureau technico-commercial / \* Contactar con nuestra oficina técnica comercial / \* Contatar o nosso departamento técnico comercial



### Input Shaft - PAM

I - Hydraulic motor

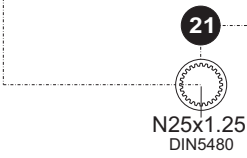
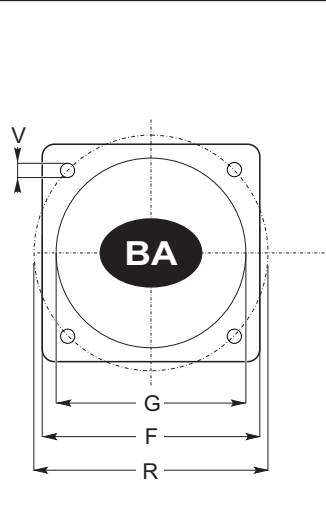
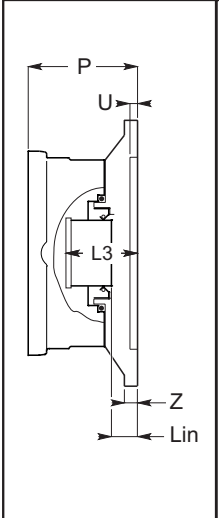
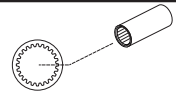

<b>Kg</b>	
BA	7

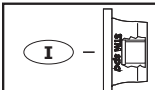

### Input Shaft - PAM

I - Hydraulic motor

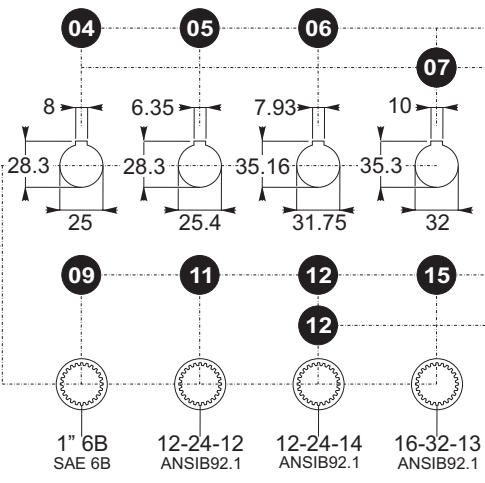
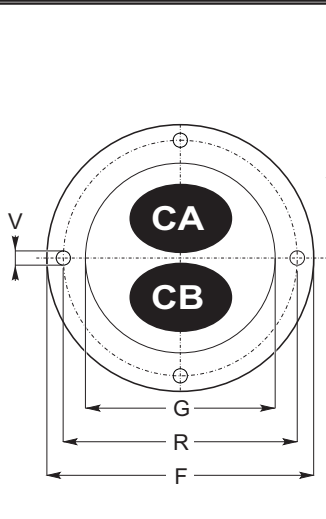
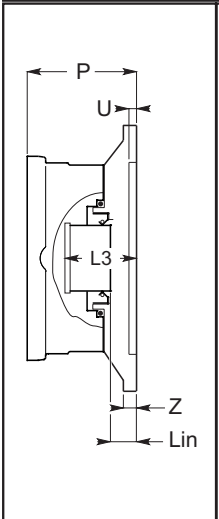
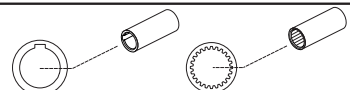

<b>Kg</b>	
CA-CB	7

	F	R	G	U	V	Z	D <sub>c</sub>	L <sub>c</sub>	L <sub>TIN</sub>	L <sub>3</sub>		
		+/- 0.1	F8				+/- 0.5					
<b>BA 21</b>	95	100	80	8	M8	16			22.5	58		
<b>CA 04</b>	130	106.4	82.6	10	M12	17			15.5	58		
<b>CA 05</b>	130	106.4	82.6	10	M12	17			15.5	58		
<b>CA 06</b>	130	106.4	82.6	10	M12	17			13	58		
<b>CA 09</b>	130	106.4	82.6	10	M12	17			20.5	58		
<b>CA 11</b>	130	106.4	82.6	10	M12	17			13	56		
<b>CA 12</b>	130	106.4	82.6	10	M12	17			13	56		
<b>CA 15</b>	130	106.4	82.6	10	M12	17			13	58		
<b>CB 07</b>	130	106.4	82.6	22	M12	29			17.5	74		
<b>CB 12</b>	130	106.4	82.6	22	M12	29			25	71.5		





	EX1				EX2 EXB2				EX3 EXB3				EX4 EXB4			
	EX 101→ 2001				EX 102→6002				EX 103→ 16003				EX 104→ 45004			
					EXB 102→ 3002				EXB103→ 10003				EXB 104→31004			
10	101				102				103				104			
20	201				202				203				204			
25	251				252				253				254			
30		301			302				303				304			
35		351			352				353				354			
40					402				403				404			
50		501			502				503				504			
70		701			702				703				704			
80			801			802			803				804			
90						902			903				904			
95						952			953				954			
100			1001			1002			1003				1004			
150				1501		1502			1503				1504			
180						1802			1803				1804			
200				2001		2002			2003				2004			
250							2502			2503			2504			
280							2802			2803			2804			
300							3002			3003			3004			
350							3502			3503			3504			
360								3602		3603			3604			
420								4202		4203			4204			
600								6002		6003			6004			
650										6503			6504			
800										8003			8004			
850										8503			8504			
1000										10003			10004			
1200										12003			12004			
1500										15003			15004			
1600											16003		16004			
2000															20004	
2500															25004	
2600															26004	
3000															30004	
3100															31004	
3200															32004	
3700															37004	
4500																45004
5500																
6800																
7500																
8000																

BA 21	93	101	109	116,5	93	101	109	116,5	93	101	109	116,5	93	101	109	116,5
CA 04	93	101	109	116,5	93	101	109	116,5	93	101	109	116,5	93	101	109	116,5
CA 05	93	101	109	116,5	93	101	109	116,5	93	101	109	116,5	93	101	109	116,5
CA 06	93	101	109	116,5	93	101	109	116,5	93	101	109	116,5	93	101	109	116,5
CA 09	93	101	109	116,5	93	101	109	116,5	93	101	109	116,5	93	101	109	116,5
CA 11	93	101	109	116,5	93	101	109	116,5	93	101	109	116,5	93	101	109	116,5
CA 12	93	101	109	116,5	93	101	109	116,5	93	101	109	116,5	93	101	109	116,5
CA 15	93	101	109	116,5	93	101	109	116,5	93	101	109	116,5	93	101	109	116,5
CB 07	105	113	121	128,5	105	113	121	128,5	105	113	121	128,5	105	113	121	128,5
CB 12	105	113	121	128,5	105	113	121	128,5	105	113	121	128,5	105	113	121	128,5

P - [mm]



### Input Shaft - PAM

*I - Hydraulic motor*

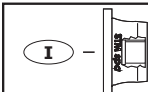
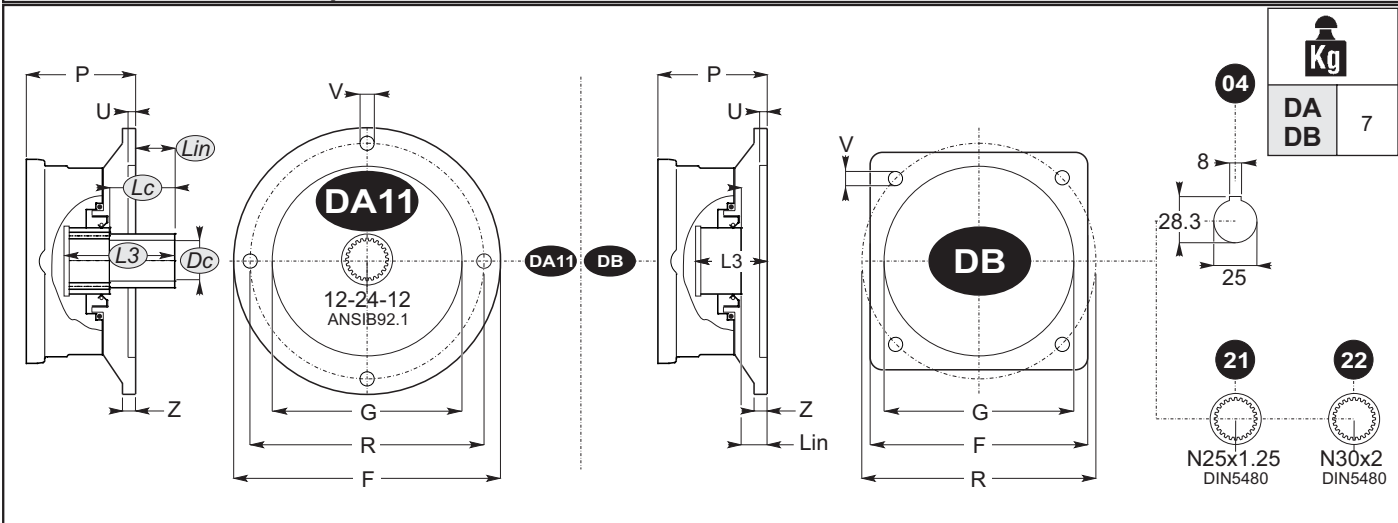
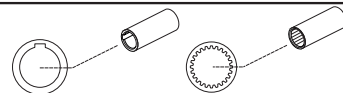

### Input Shaft - PAM

*I - Hydraulic motor*

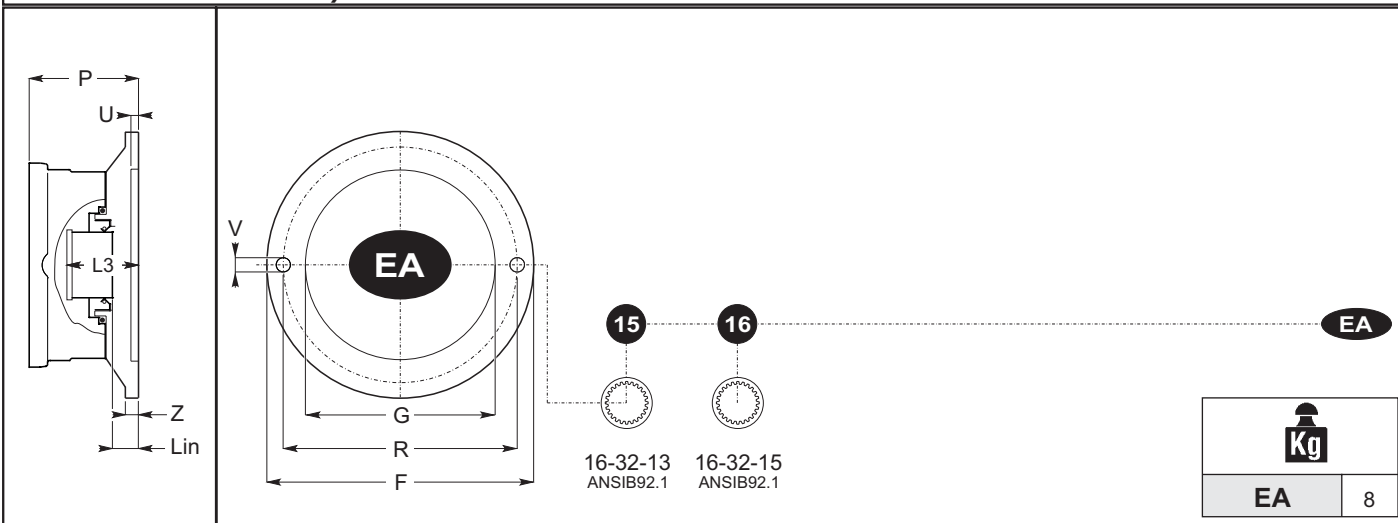
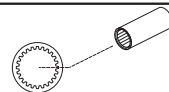

	F	R	G	U	V	Z	D <sub>c</sub>	L <sub>c</sub>	L <sub>TIN</sub>	L3	
		+/- 0.1	F8				+/- 0.5				
<b>DA 11</b>	145	125	100	8	M10	11	29	32	25	52	
<b>DB 04</b>	118	125	100	10	M10	30	-	-	29	73	
<b>DB 21</b>	118	125	100	10	M10	30	-	-	36	73	
<b>DB 22</b>	118	125	100	10	M10	30	-	-	27	68	
<b>EA 15</b>	170	146	101.6	10	M14	23	-	-	10	56	
<b>EA 16</b>	170	146	101.6	10	M14	23	-	-	14	56.5	



	EX1				EX2 EXB2				EX3 EXB3				EX4 EXB4			
	EX 101→ 2001				EX 102→6002				EX 103→ 16003				EX 104→ 45004			
					EXB 102→ 3002				EXB103→ 10003				EXB 104→31004			
10	101				102				103				104			
20	201				202				203				204			
25	251				252				253				254			
30		301			302				303				304			
35		351			352				353				354			
40					402				403				404			
50		501			502				503				504			
70		701			702				703				704			
80			801			802			803				804			
90						902			903				904			
95						952			953				954			
100			1001			1002			1003				1004			
150				1501		1502			1503				1504			
180						1802			1803				1804			
200				2001		2002			2003				2004			
250							2502			2503			2504			
280							2802			2803			2804			
300							3002			3003			3004			
350							3502			3503			3504			
360								3602		3603			3604			
420								4202		4203			4204			
600								6002		6003			6004			
650										6503			6504			
800										8003			8004			
850										8503			8504			
1000										10003			10004			
1200										12003			12004			
1500										15003			15004			
1600											16003		16004			
2000															20004	
2500															25004	
2600															26004	
3000															30004	
3100															31004	
3200															32004	
3700															37004	
4500																45004
5500																
6800																
7500																
8000																

DA 11	87	95	103	110,5	87	95	103	110,5	87	95	103	110,5	87	95	103	110,5
DB 04	107	115	123	130,5	107	115	123	130,5	117	115	123	130,5	107	115	123	130,5
DB 21	107	115	123	130,5	107	115	123	130,5	117	115	123	130,5	107	115	123	130,5
DB 22	107	115	123	130,5	107	115	123	130,5	117	115	123	130,5	107	115	123	130,5
EA 15	90	98	106	113,5	90	98	106	113,5	90	98	106	113,5	90	98	106	113,5
EA 16	90	98	106	113,5	90	98	106	113,5	90	98	106	113,5	90	98	106	113,5

P - [mm]

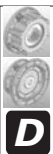

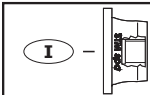

### Input Shaft - PAM

I - Hydraulic motor

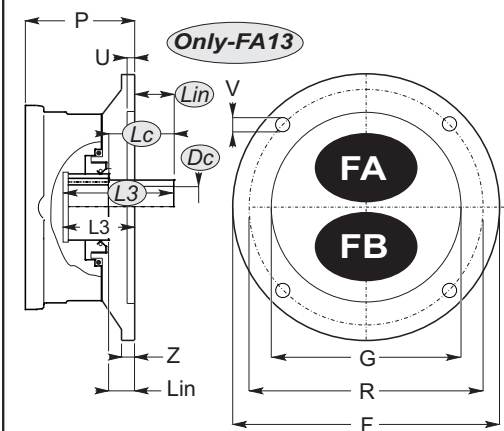
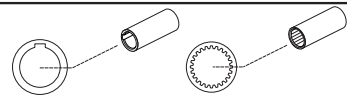

Only-FA13

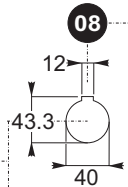

08	13	14	22	23	24	28	FA FB
12-24-16 ANSIB92.1	12-24-17 ANSIB92.1	N30x2 DIN5480	N35x2 DIN5480	N40x2 DIN5480	N32x2 DIN5480		

<b>Kg</b>	
FA-FB	8

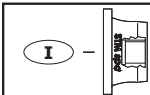

### Input Shaft - PAM

I - Hydraulic motor

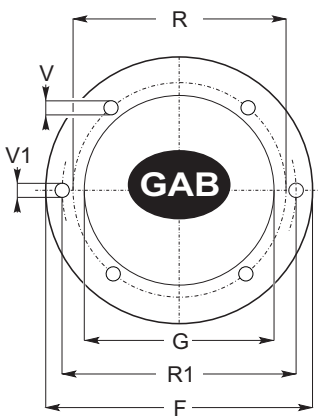
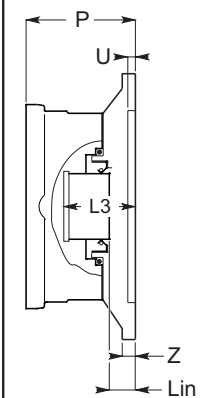
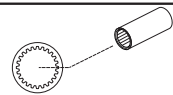

12	14	17	27	GAB
12-24-14 ANSIB92.1	12-24-17 ANSIB92.1	16-32-21 ANSIB92.1	16-32-23 ANSIB92.1	

<b>Kg</b>	
GAB	8

	F	R	R1	G	U	V	V1	Z	Dc	Lc	L <sub>IN</sub>	L3		
			+/- 0,1	F8										
<b>FA 13</b>	182	160	-	125	35	M12	-	46	39	44	25	69		
<b>FA 22</b>	182	160	-	125	35	M12	-	46			34	79		
<b>FA 23</b>	182	160	-	125	35	M12	-	46			33	74		
<b>FA 24</b>	182	160	-	125	35	M12	-	46			33	74		
<b>FA 28</b>	182	160	-	125	35	M12	-	46			33	74		
<b>FB 08</b>	182	160	-	125	10	M12	-	86			35	118		
<b>FB 14</b>	182	160	-	125	10	M12	-	86			60	118		
<b>GAB 12</b>	200	162	181	127	20	M14	M16	30			21	67.5		
<b>GAB 14</b>	200	162	181	127	20	M14	M16	30			8.5	66.5		
<b>GAB 17</b>	200	162	181	127	20	M14	M16	30			21	62		
<b>GAB 27</b>	200	162	181	127	20	M14	M16	30			21	64		



	EX1				EX2 EXB2				EX3 EXB3				EX4 EXB4			
	EX 101→ 2001				EX 102→6002				EX 103→ 16003				EX 104→ 45004			
					EXB 102→ 3002				EXB103→ 10003				EXB 104→31004			
10	101				102				103				104			
20	201				202				203				204			
25	251				252				253				254			
30		301			302				303				304			
35		351			352				353				354			
40					402				403				404			
50		501			502				503				504			
70		701			702				703				704			
80			801			802			803				804			
90						902			903				904			
95						952			953				954			
100			1001			1002			1003				1004			
150				1501		1502			1503				1504			
180						1802			1803				1804			
200				2001		2002			2003				2004			
250							2502			2503			2504			
280							2802			2803			2804			
300							3002			3003			3004			
350							3502			3503			3504			
360								3602		3603			3604			
420								4202		4203			4204			
600								6002		6003			6004			
650										6503			6504			
800										8003			8004			
850										8503			8504			
1000										10003			10004			
1200										12003			12004			
1500										15003			15004			
1600											16003		16004			
2000															20004	
2500															25004	
2600															26004	
3000															30004	
3100															31004	
3200															32004	
3700															37004	
4500																45004
5500																
6800																
7500																
8000																
FA 13	113	121	129	136,5	113	121	129	136,5	113	121	129	136,5	113	121	129	136,5
FA 22	113	121	129	136,5	113	121	129	136,5	113	121	129	136,5	113	121	129	136,5
FA 23	113	121	129	136,5	113	121	129	136,5	113	121	129	136,5	113	121	129	136,5
FA 24	113	121	129	136,5	113	121	129	136,5	113	121	129	136,5	113	121	129	136,5
FA 28	113	121	129	136,5	113	121	129	136,5	113	121	129	136,5	113	121	129	136,5
FB 08	153	161	169	176,5	153	161	169	176,5	153	161	169	176,5	153	161	169	176,5
FB 14	153	161	169	176,5	153	161	169	176,5	153	161	169	176,5	153	161	169	176,5
GAB 12	101	109	117	124,5	101	109	117	124,5	101	109	117	124,5	101	109	117	124,5
GAB 14	101	109	117	124,5	101	109	117	124,5	101	109	117	124,5	101	109	117	124,5
GAB 17	101	109	117	124,5	101	109	117	124,5	101	109	117	124,5	101	109	117	124,5
GAB 27	101	109	117	124,5	101	109	117	124,5	101	109	117	124,5	101	109	117	124,5

P - [mm]

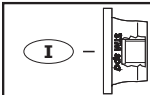

### Input Shaft - PAM

*I - Hydraulic motor*

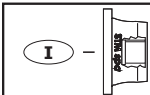
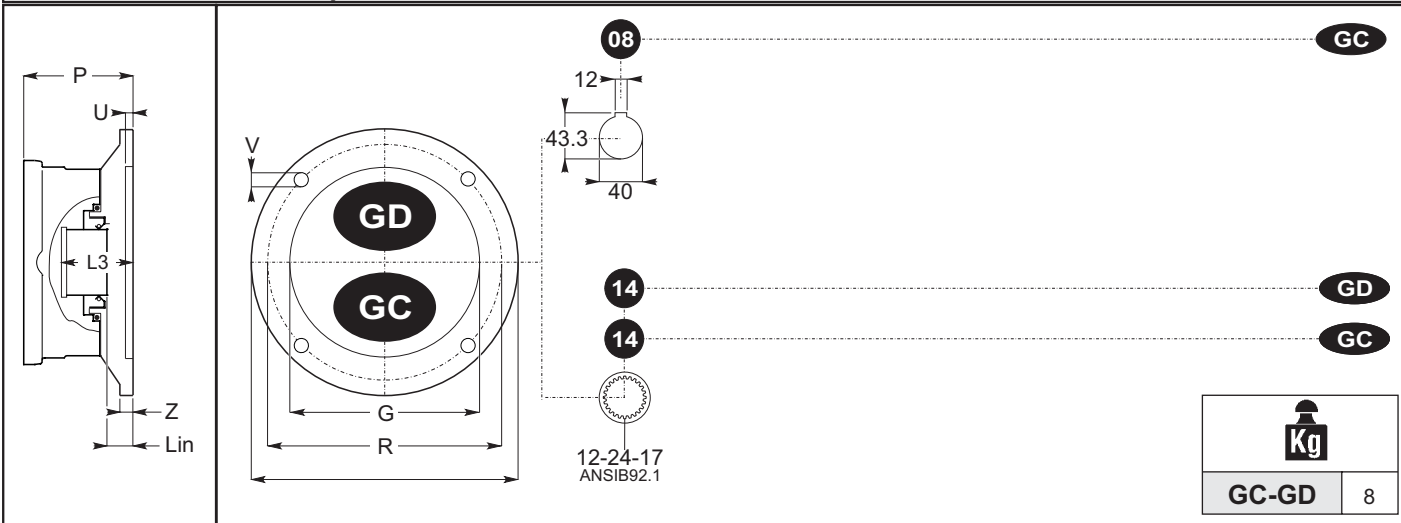
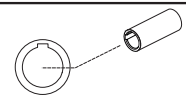

### Input Shaft - PAM

*I - Hydraulic motor*

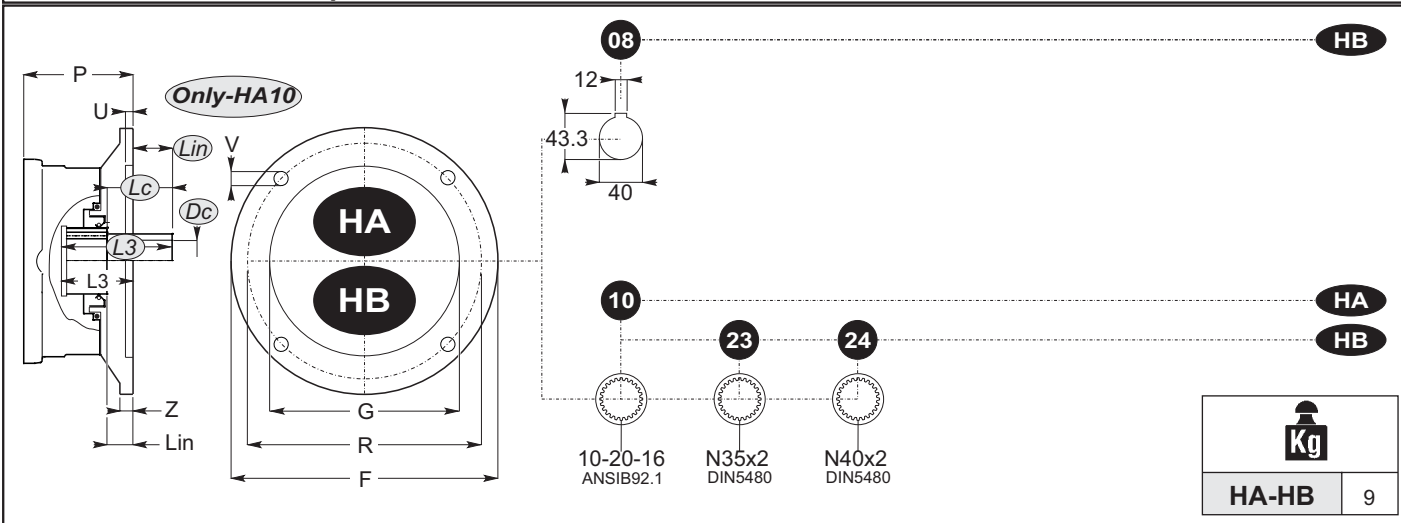
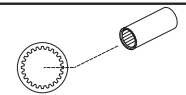

	F	R	R1	G	U	V	V1	Z	Dc	Lc	L <sub>IN</sub>	L3		
			+/- 0.1	F8										
<b>GC 08</b>	200	162	-	127	73	M12	-	86			35	118		
<b>GC 14</b>	200	162	-	127	73	M12	-	86			60.5	118.5		
<b>GD 14</b>	200	162	-	127	18	M12	-	57			31.5	89.5		
<b>HA 10</b>	207	180	-	140	10	M12	-	29	46	44	23	76		
<b>HB 08</b>	207	180	-	140	12	M12	-	50		-	4.5	87.5		
<b>HB 23</b>	207	180	-	140	12	M12	-	50			42	82		
<b>HB 24</b>	207	180	-	140	12	M12	-	50			42	82		

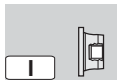

	EX1				EX2  EXB2				EX3  EXB3				EX4  EXB4			
	EX 101→ 2001				EX 102→6002				EX 103→ 16003				EX 104→ 45004			
					EXB 102→ 3002				EXB103→ 10003				EXB 104→31004			
10	101				102				103				104			
20	201				202				203				204			
25	251				252				253				254			
30		301			302				303				304			
35		351			352				353				354			
40					402				403				404			
50		501			502				503				504			
70		701			702				703				704			
80			801			802			803				804			
90						902			903				904			
95						952			953				954			
100			1001			1002			1003				1004			
150				1501		1502			1503				1504			
180						1802			1803				1804			
200				2001		2002			2003				2004			
250							2502			2503			2504			
280							2802			2803			2804			
300							3002			3003			3004			
350							3502			3503			3504			
360								3602		3603			3604			
420								4202		4203			4204			
600								6002		6003			6004			
650										6503			6504			
800										8003			8004			
850										8503			8504			
1000										10003			10004			
1200										12003			12004			
1500										15003			15004			
1600											16003		16004			
2000															20004	
2500															25004	
2600															26004	
3000															30004	
3100															31004	
3200															32004	
3700															37004	
4500																45004
5500																
6800																
7500																
8000																

GC 08	153	161	169	176,5	153	161	169	176,5	153	161	169	176,5	153	161	169	176,5
GC 14	153	161	169	176,5	153	161	169	176,5	153	161	169	176,5	153	161	169	176,5
GD 14	124	132	140	147,5	124	132	140	147,5	124	132	140	147,5	124	132	140	147,5
HA 10	101	109	117	124,5	101	109	117	124,5	101	109	117	124,5	101	109	117	124,5
HB 08	122	130	138	145,5	122	130	138	145,5	122	130	138	145,5	122	130	138	145,5
HB 23	122	130	138	145,5	122	130	138	145,5	122	130	138	145,5	122	130	138	145,5
HB 24	122	130	138	145,5	122	130	138	145,5	122	130	138	145,5	122	130	138	145,5

P - [mm]

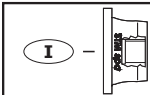

### Input Shaft - PAM

*I - Hydraulic motor*

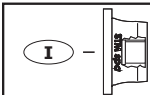
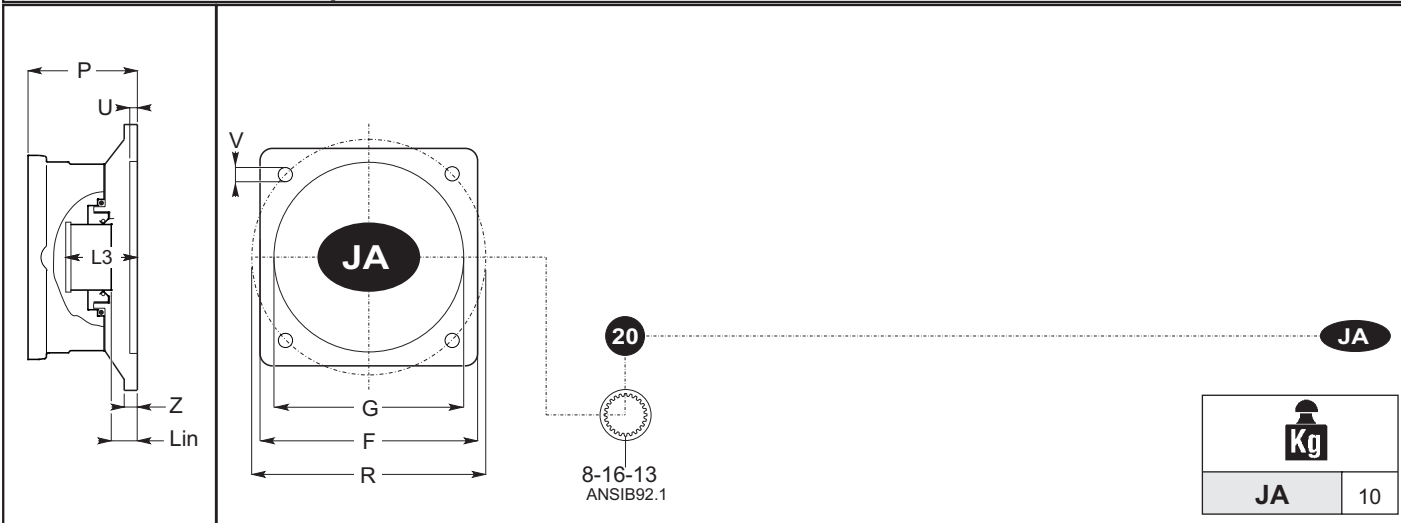
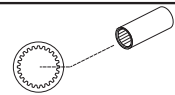

### Input Shaft - PAM

*I - Hydraulic motor*

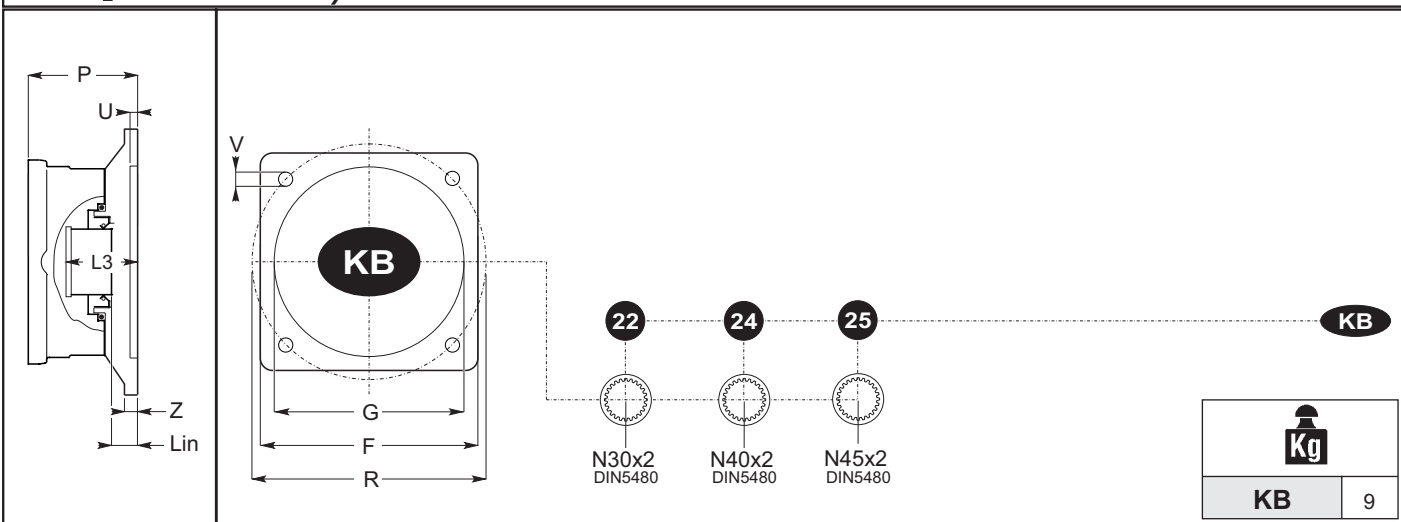
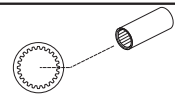

	F	R	G	U	V	Z	L <sub>IN</sub>	L <sub>3</sub>		
<b>JA 20</b>	197	+/-0.1 228.6	F8 152.4	15	∅ 21	30	30.5	80		
<b>KB 22</b>	180	200	160	10	M16	30	50	93		
<b>KB 24</b>	180	200	160	10	M16	30	50	93		
<b>KB 25</b>	180	200	160	10	M16	30	46	98		





	EX1				EX2  EXB2				EX3  EXB3				EX4  EXB4			
	EX 101→ 2001				EX 102→6002				EX 103→ 16003				EX 104→ 45004			
					EXB 102→ 3002				EXB103→ 10003				EXB 104→31004			
10	101				102				103				104			
20	201				202				203				204			
25	251				252				253				254			
30		301			302				303				304			
35		351			352				353				354			
40					402				403				404			
50		501			502				503				504			
70		701			702				703				704			
80			801			802			803				804			
90						902			903				904			
95						952			953				954			
100			1001			1002			1003				1004			
150				1501		1502			1503				1504			
180						1802			1803				1804			
200				2001		2002			2003				2004			
250							2502			2503			2504			
280							2802			2803			2804			
300							3002			3003			3004			
350							3502			3503			3504			
360								3602		3603			3604			
420								4202		4203			4204			
600								6002		6003			6004			
650										6503			6504			
800										8003			8004			
850										8503			8504			
1000										10003			10004			
1200										12003			12004			
1500										15003			15004			
1600											16003		16004			
2000															20004	
2500															25004	
2600															26004	
3000															30004	
3100															31004	
3200															32004	
3700															37004	
4500																45004
5500																
6800																
7500																
8000																

JA 20	117	125	133	140,5	117	125	133	140,5	117	125	133	140,5	117	125	133	140,5
KB 22	130	138	146	153,5	130	138	146	153,5	130	138	146	153,5	130	138	146	153,5
KB 24	130	138	146	153,5	130	138	146	153,5	130	138	146	153,5	130	138	146	153,5
KB 25	130	138	146	153,5	130	138	146	153,5	130	138	146	153,5	130	138	146	153,5

P - [mm]



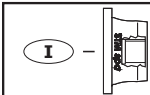

### Input Shaft - PAM

*I - Hydraulic motor*

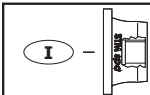
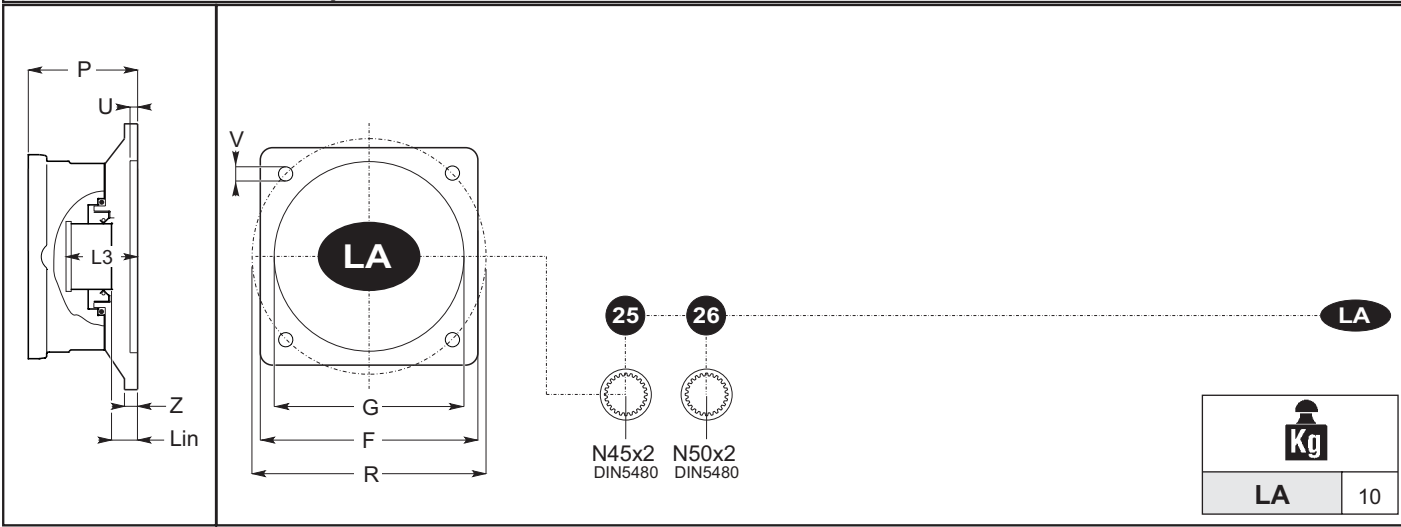
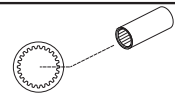

### Input Shaft - PAM

*I - Hydraulic motor*

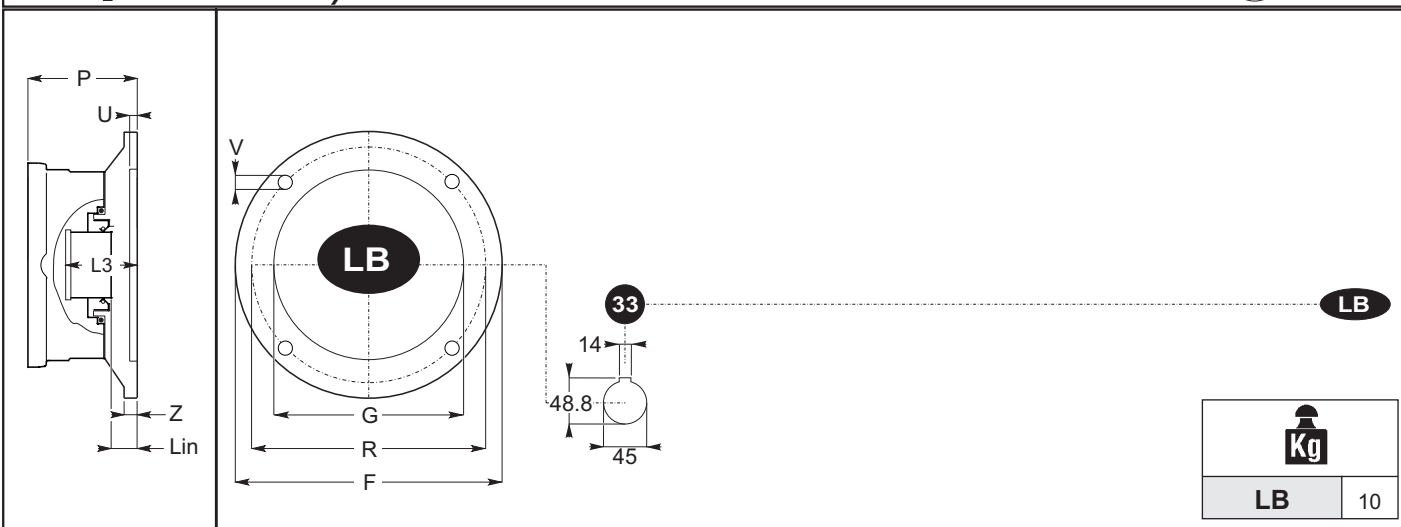
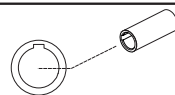

	F	R +/-0.1	G F8	U	V	Z	L <sub>IN</sub>	L <sub>3</sub>		
<b>LA 25</b>	210	224	180	12	M16	18	45	97		
<b>LA 26</b>	210	224	180	12	M16	18	46.5	96.5		
<b>LB 33</b>	265	224	180	20	M16	10	43.5	135.5		



	EX1				EX2 EXB2				EX3 EXB3				EX4 EXB4			
	EX 101→ 2001				EX 102→6002				EX 103→ 16003				EX 104→ 45004			
					EXB 102→ 3002				EXB103→ 10003				EXB 104→31004			
10	101				102				103				104			
20	201				202				203				204			
25	251				252				253				254			
30		301			302				303				304			
35		351			352				353				354			
40					402				403				404			
50		501			502				503				504			
70		701			702				703				704			
80			801		802				803				804			
90					902				903				904			
95					952				953				954			
100			1001		1002				1003				1004			
150				1501	1502				1503				1504			
180					1802				1803				1804			
200				2001	2002				2003				2004			
250						2502			2503				2504			
280						2802			2803				2804			
300						3002			3003				3004			
350						3502			3503				3504			
360							3602		3603				3604			
420							4202		4203				4204			
600							6002		6003				6004			
650									6503				6504			
800									8003				8004			
850									8503				8504			
1000									10003				10004			
1200									12003				12004			
1500									15003				15004			
1600										16003			16004			
2000															20004	
2500															25004	
2600															26004	
3000															30004	
3100															31004	
3200															32004	
3700															37004	
4500																45004
5500																
6800																
7500																
8000																

LA 25	129	137	145	152,5	129	137	145	152,5	129	137	145	152,5	129	137	145	152,5
LA 26	129	137	145	152,5	129	137	145	152,5	129	137	145	152,5	129	137	145	152,5
LB 33	172.5	180.5	188.5	196,0	172.5	180.5	188.5	196,0	172.5	180.5	188.5	196,0	172.5	180.5	188.5	196,0

P - [mm]





### Input Shaft - PAM

*I - Hydraulic motor*

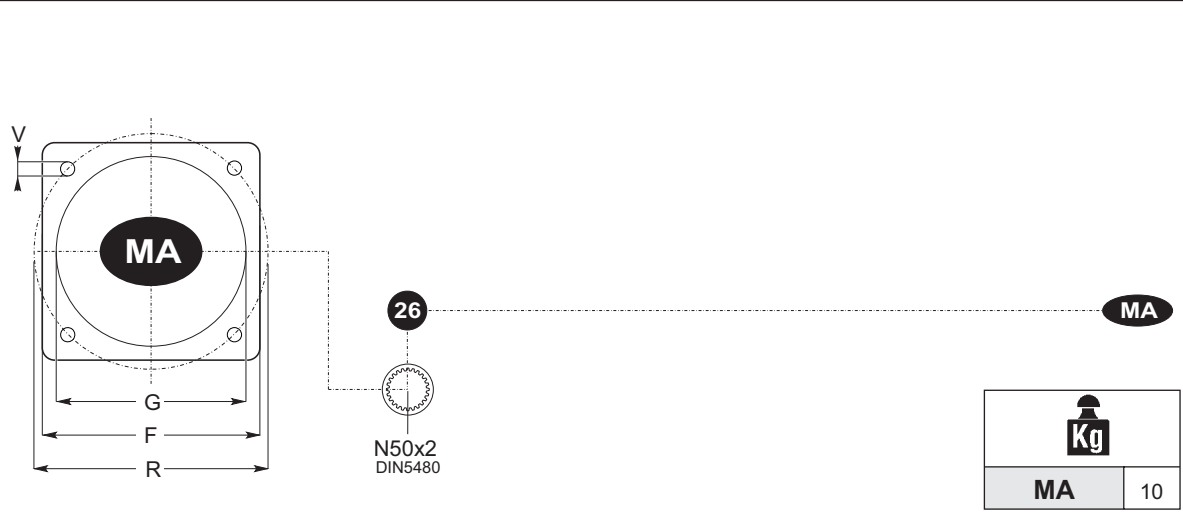
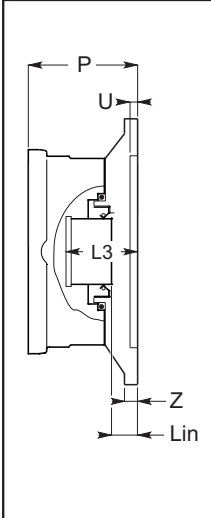
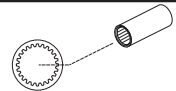

<b>Kg</b>	
MA	10

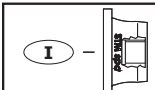

### Input Shaft - PAM

*I - Hydraulic motor*

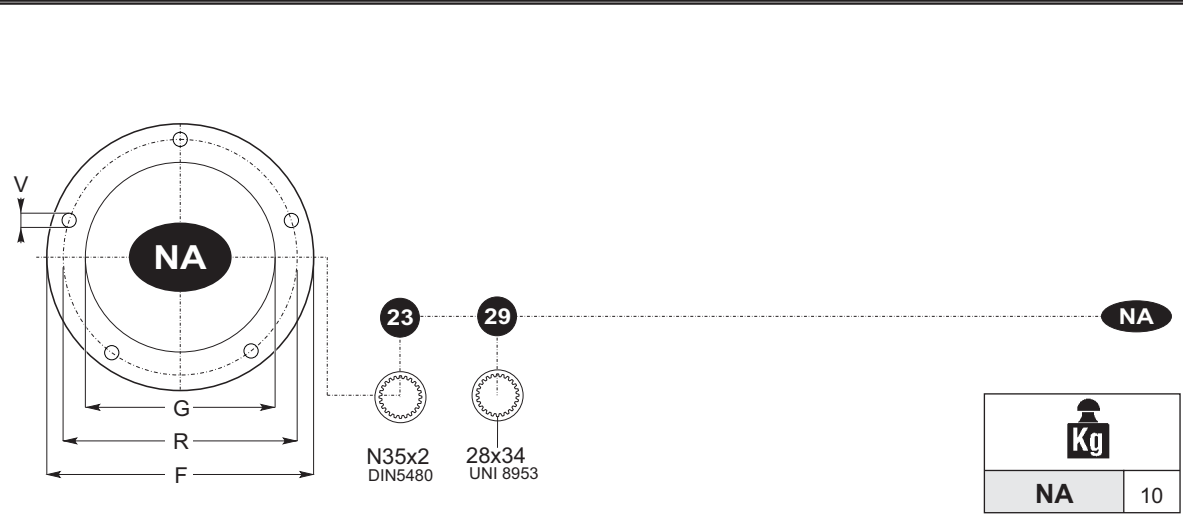
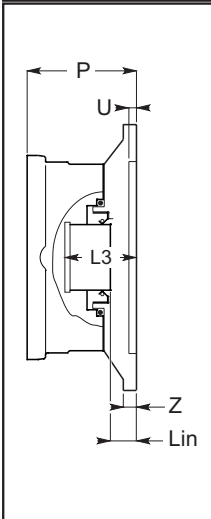
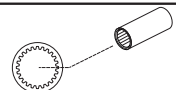

<b>Kg</b>	
NA	10

	F	R	G	U	V	Z	L <sub>IN</sub>	L <sub>3</sub>		
<b>MA 26</b>	236	250 +/-0.1	F8	11	M20	20	50.5	100.5		
<b>NA 23</b>	195	160	125	12	M10	43	36	77.5		
<b>NA 29</b>	195	160	125	12	M10	43	40	79		

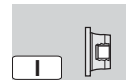

	EX1				EX2  EXB2				EX3  EXB3				EX4  EXB4			
	EX 101→ 2001				EX 102→6002				EX 103→ 16003				EX 104→ 45004			
					EXB 102→ 3002				EXB103→ 10003				EXB 104→31004			
10	101				102				103				104			
20	201				202				203				204			
25	251				252				253				254			
30		301			302				303				304			
35		351			352				353				354			
40					402				403				404			
50		501			502				503				504			
70		701			702				703				704			
80			801		802				803				804			
90					902				903				904			
95					952				953				954			
100			1001		1002				1003				1004			
150				1501	1502				1503				1504			
180					1802				1803				1804			
200				2001	2002				2003				2004			
250						2502			2503				2504			
280						2802			2803				2804			
300						3002			3003				3004			
350						3502			3503				3504			
360							3602		3603				3604			
420							4202		4203				4204			
600							6002		6003				6004			
650									6503				6504			
800									8003				8004			
850									8503				8504			
1000									10003				10004			
1200									12003				12004			
1500									15003				15004			
1600										16003			16004			
2000															20004	
2500															25004	
2600															26004	
3000															30004	
3100															31004	
3200															32004	
3700															37004	
4500																45004
5500																
6800																
7500																
8000																

MA 26	133	141	149	156,5	133	141	149	156,5	133	141	149	156,5	133	141	149	156,5
NA 23	116	124	132	139,5	116	124	132	139,5	116	124	132	139,5	116	124	132	139,5
NA 29	116	124	132	139,5	116	124	132	139,5	116	124	132	139,5	116	124	132	139,5

P - [mm]

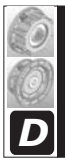

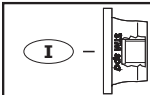

### Input Shaft - PAM

*I - Hydraulic motor*

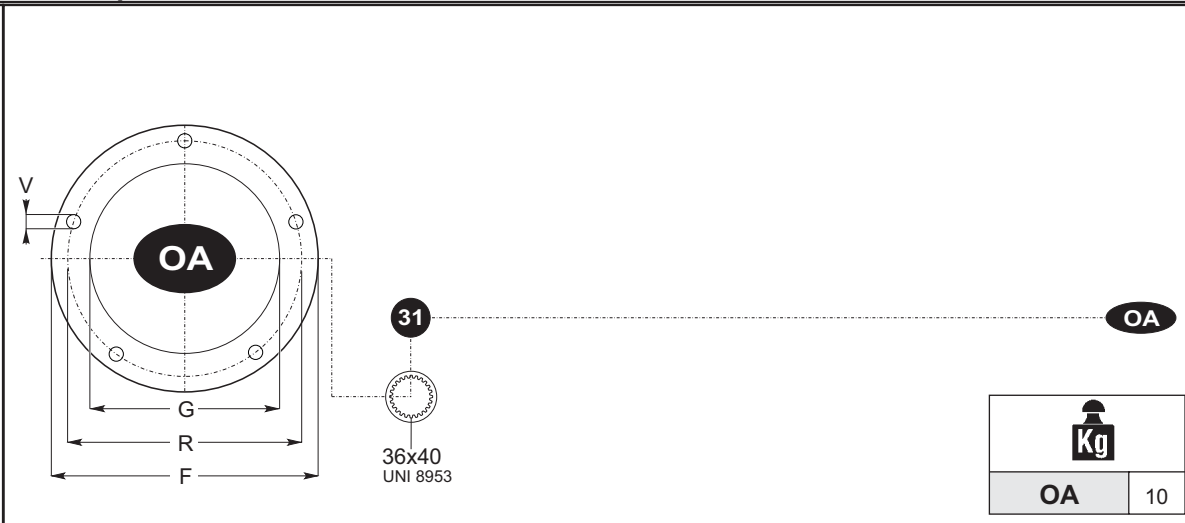
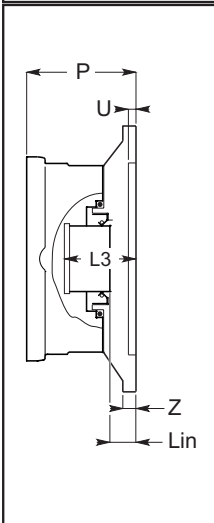
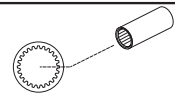

<b>Kg</b>	
OA	10

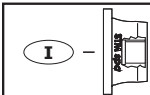

### Input Shaft - PAM

*I - Hydraulic motor*

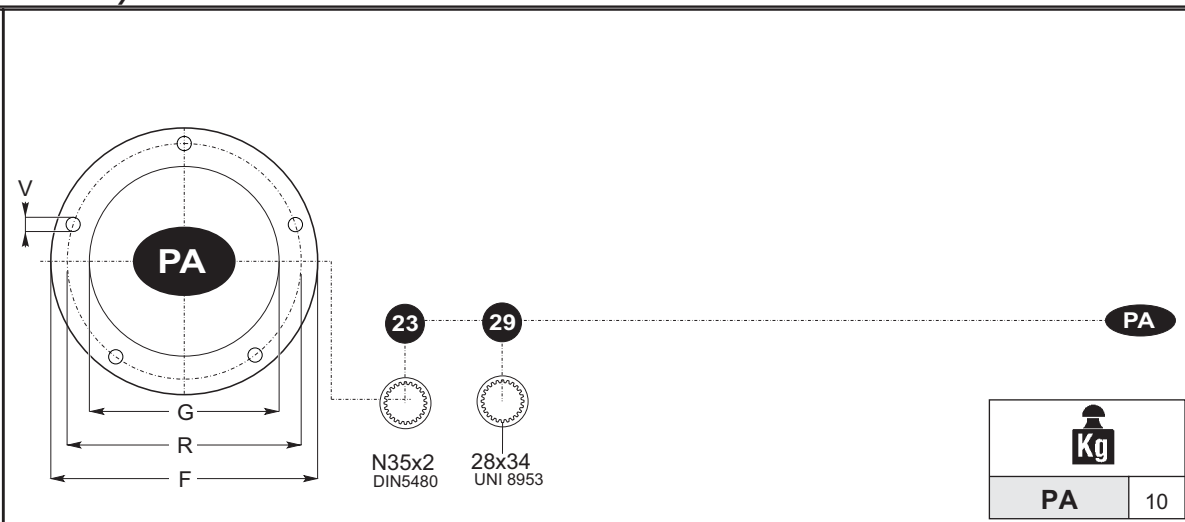
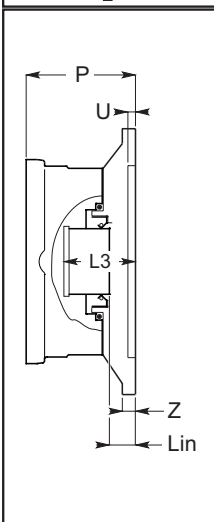
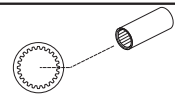

<b>Kg</b>	
PA	10

	F	R	G	U	V	Z	L <sub>IN</sub>	L <sub>3</sub>		
<b>OA 31</b>	288	+/-0.1 250	F8 150	7	∅ 14	15	27	77		
<b>PA 23</b>	233	210	175	6	∅ 14	16	15	56.5		
<b>PA 29</b>	233	210	175	6	∅ 14	16	22	62		



	EX1				EX2  EXB2				EX3  EXB3				EX4  EXB4			
	EX 101→ 2001				EX 102→6002				EX 103→ 16003				EX 104→ 45004			
					EXB 102→ 3002				EXB103→ 10003				EXB 104→31004			
10	101				102				103				104			
20	201				202				203				204			
25	251				252				253				254			
30		301			302				303				304			
35		351			352				353				354			
40					402				403				404			
50		501			502				503				504			
70		701			702				703				704			
80			801		802				803				804			
90					902				903				904			
95					952				953				954			
100			1001		1002				1003				1004			
150				1501	1502				1503				1504			
180					1802				1803				1804			
200				2001	2002				2003				2004			
250						2502			2503				2504			
280						2802			2803				2804			
300						3002			3003				3004			
350						3502			3503				3504			
360							3602		3603				3604			
420							4202		4203				4204			
600							6002		6003				6004			
650									6503				6504			
800									8003				8004			
850									8503				8504			
1000									10003				10004			
1200									12003				12004			
1500									15003				15004			
1600										16003			16004			
2000															20004	
2500															25004	
2600															26004	
3000															30004	
3100															31004	
3200															32004	
3700															37004	
4500																45004
5500																
6800																
7500																
8000																

OA 31	109	117	125	132,5	109	117	125	132,5	109	117	125	132,5	109	117	125	132,5
PA 23	95	103	111	118,5	95	103	111	118,5	95	103	111	118,5	95	103	111	118,5
PA 29	95	103	111	118,5	95	103	111	118,5	95	103	111	118,5	95	103	111	118,5

P - [mm]





**Input Shaft - PAM**  
I - Hydraulic motor

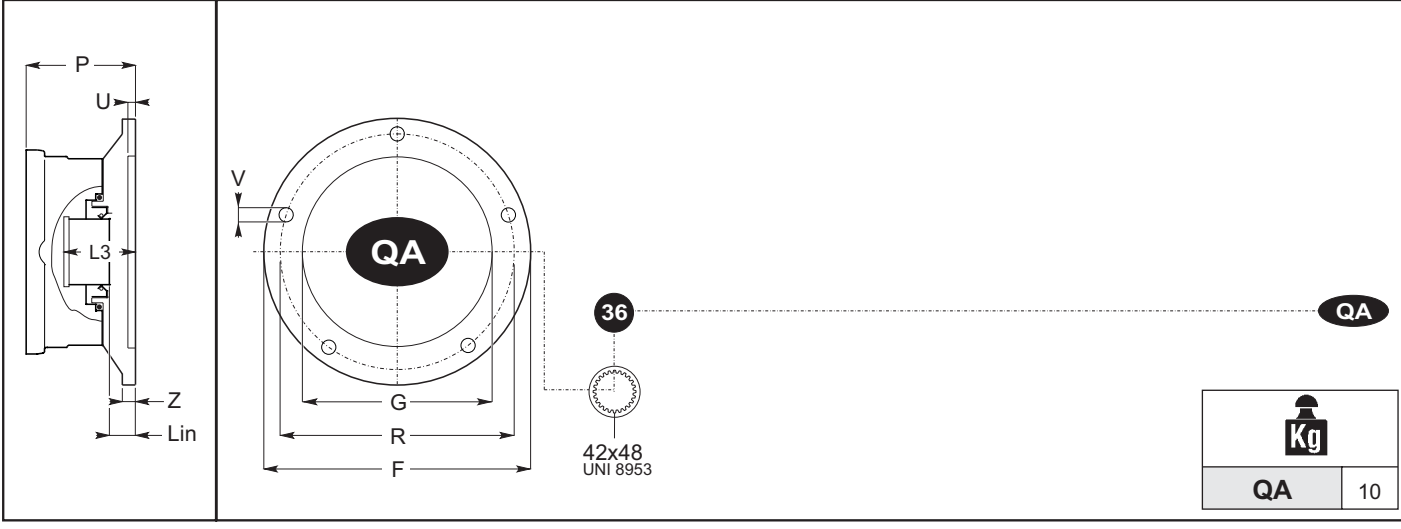
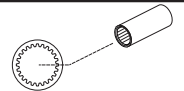

	F	R	G	U	V	Z	L <sub>IN</sub>	L <sub>3</sub>		
<b>QA 36</b>	256	+/-0.1 232	F8 175	18	M10	15	37	86		



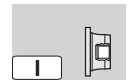

	EX1				EX2  EXB2				EX3  EXB3				EX4  EXB4			
	EX 101→ 2001				EX 102→6002				EX 103→ 16003				EX 104→ 45004			
					EXB 102→ 3002				EXB103→ 10003				EXB 104→31004			
10	101				102				103				104			
20	201				202				203				204			
25	251				252				253				254			
30		301			302				303				304			
35		351			352				353				354			
40					402				403				404			
50		501			502				503				504			
70		701			702				703				704			
80			801		802				803				804			
90					902				903				904			
95					952				953				954			
100			1001		1002				1003				1004			
150				1501	1502				1503				1504			
180					1802				1803				1804			
200				2001	2002				2003				2004			
250						2502			2503				2504			
280						2802			2803				2804			
300						3002			3003				3004			
350						3502			3503				3504			
360							3602		3603				3604			
420							4202		4203				4204			
600							6002		6003				6004			
650									6503				6504			
800									8003				8004			
850									8503				8504			
1000									10003				10004			
1200									12003				12004			
1500									15003				15004			
1600										16003			16004			
2000															20004	
2500															25004	
2600															26004	
3000															30004	
3100															31004	
3200															32004	
3700															37004	
4500																45004
5500																
6800																
7500																
8000																

QA 36	119	127	135	142.5	119	127	135	142.5	119	127	135	142.5	119	127	135	142.5
P - [mm]																

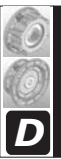

4.0 Type de Moteur / Code STM

4.0 Tipo Motor / Código STM

4.0 Tipo Motor / Código STM

Hydraulic Motor		Input Gearbox			
Company	Motor Type	D	G	R	Code STM
AXIAL PUMP	M2 24-50	16/32-15	101,6	146	EA16
AXIAL PUMP	M3 40-65	16/32-15	101,6	146	EA16
AXIAL PUMP	M2 24-50	16/32-13	101,6	146	EA15
AXIAL PUMP	M3 40-65	16/32-13	101,6	146	EA15
CALZONI	TYPE MR 250	8x42x48	175	232	QA36
DANFOSS	OMH 200-500	12/24-14	82,55	106,4	CB12
DANFOSS	OMS 80-400	12/24-14	82,55	106,4	CB12
DANFOSS	OMP 25-400	25	82,55	106,4	CA4
DANFOSS	OMR 50-375	25	82,55	106,4	CA4
DANFOSS	OMP 25-400	25,4	82,55	106,4	CA5
DANFOSS	OMR 50-375	25,4	82,55	106,4	CA5
DANFOSS	OMP 25-400	32	82,55	106,4	CB7
DANFOSS	OMR 50-375	32	82,55	106,4	CB7
DANFOSS	OMH 200-500	32	82,55	106,4	CB7
DANFOSS	OMS 80-400	32	82,55	106,4	CB7
DANFOSS	OMT 160-500	40	125	160	FB8
DANFOSS	OMP 25-400	1"6B	82,55	106,4	CA9
DANFOSS	OMR 50-375	1"6B	82,55	106,4	CA9
DANFOSS	OMSS 80-400	12/24-12	100	125	DA11
DANFOSS	OMTS 160-500	12/24-16	125	160	FA13
DANFOSS	OMT 160-500	12/24-17	125	160	FB14
DANFOSS	OMVS 315-800	10/20-16	140	180	HA10
DINAMIC OIL	MGL 50-400	25	82,55	106,4	CA4
DINAMIC OIL	MGLR 50-375	25	82,55	106,4	CA4
DINAMIC OIL	MGT 50-400	25	82,55	106,4	CA4
DINAMIC OIL	MGL 50-401	25,4	82,55	106,4	CA5
DINAMIC OIL	MGLR 50-375	25,4	82,55	106,4	CA5
DINAMIC OIL	MGT 50-400	25,4	82,55	106,4	CA5
DINAMIC OIL	MGL 50-402	1"6B	82,55	106,4	CA9
DINAMIC OIL	MGLR 50-375	1"6B	82,55	106,4	CA9
DINAMIC OIL	MGT 50-400	1"6B	82,55	106,4	CA9
EATON(CHAR-LYNN)	SERIE 4000	12/24-17	127	162	GA14
EATON(CHAR-LYNN)	SERIE 2000	25	82,55	106,4	CA4
EATON(CHAR-LYNN)	SERIE 2000	25,4	82,55	106,4	CA5
EATON(CHAR-LYNN)	SERIE 2000	31,75	82,55	106,4	CA6
EATON(CHAR-LYNN)	SERIE 2000	32	82,55	106,4	CB7
EATON(CHAR-LYNN)	SERIE 2000	1"6B	82,55	106,4	CA9
GEOLINK	GLS 80-315	12/24-14	82,55	106,4	CB12
GEOLINK	GHL 50-400	25	82,55	106,4	CA4
GEOLINK	GFS 50-400	25	82,55	106,4	CA4
GEOLINK	GKS 50-400	25	82,55	106,4	CA4
GEOLINK	GLS 80-315	32	82,55	106,4	CB7
GEOLINK	GHL 50-400	1"6B	82,55	106,4	CA9
GEOLINK	GFS 50-400	1"6B	82,55	106,4	CA9
GEOLINK	GKS 50-400	1"6B	82,55	106,4	CA9
HP HYDRAULIC	M4MF 21-28	25,4	82,55	106,4	CA5
HP HYDRAULIC	M4MF 21-28	16/32-13	82,55	106,4	CA15
HP HYDRAULIC	M4PV 21-28	16/32-15	101,6	146	EA16
HP HYDRAULIC	M4PV 34-65	16/32-15	101,6	146	EA16
HP HYDRAULIC	M4PV 21-28	16/32-13	101,6	146	EA15
HP HYDRAULIC	M4PV 34-65	16/32-13	101,6	146	EA15
HP HYDRAULIC	M4MF 34-65	16/32-13	101,6	146	EA15
HP HYDRAULIC	M4MV 34-65	16/32-13	101,6	146	EA15
HP HYDRAULIC	M4MF 34-65	16/32-15	101,6	146	EA16
HP HYDRAULIC	M4MV 34-65	16/32-15	101,6	146	EA16
LINDE	HMV 35	16/32-15	101,6	146	EA16
LINDE	HMF 105	16/32-23	127	181	GB27
LINDE	HMF 50-75	16/32-21	127	181	GB17
M + S	EPM 40-630	12/24-14	82,55	106,4	CB12
M + S	EPRM 50-400	12/24-14	82,55	106,4	CB12
M + S	EPM 40-630	25	82,55	106,4	CA4
M + S	EPRM 50-400	25	82,55	106,4	CA4
M + S	EPM 40-630	25,4	82,55	106,4	CA5
M + S	EPRM 50-400	25,4	82,55	106,4	CA5
M + S	EPM 40-630	32	82,55	106,4	CB7
M + S	EPRM 50-400	32	82,55	106,4	CB7
M + S	EPRM 80-400	32	82,55	106,4	CB7
M + S	EPM 40-630	1"6B	82,55	106,4	CA9
M + S	EPRM 50-400	1"6B	82,55	106,4	CA9
M + S	EPMT 160-500	12/24-17	125	160	FB14
REXROTH	A2FM 23-32	25	100	125	DB4
REXROTH	A4FM 22-28	16/32-13	101,6	146	EA15
REXROTH	A10FM 23-28	16/32-13	101,6	146	EA15
REXROTH	A4FM 22-28	16/32-15	101,6	146	EA16
REXROTH	A2FM 10-16	N25x1,25	80	100	BA21
REXROTH	A2FM 23-32	N25x1,25	100	125	DB21
REXROTH	A6VM 28	N25x1,25	100	125	DB21
REXROTH	A2FM 23-32	N30x2	100	125	DB22
REXROTH	A6VM 28	N30x2	100	125	DB22
REXROTH	A2FM 45-63	N30x2	125	160	FA22
REXROTH	A6VM 55	N30x2	125	160	FA22
REXROTH	A2FM 45-63	N35x2	125	160	FA23
REXROTH	A6VM 55	N35x2	125	160	FA23
REXROTH	A2FM 80-90	N35x2	140	180	HB23
REXROTH	A6VM 80	N35x2	140	180	HB23
REXROTH	A2FM 80-90	N40x2	140	180	HB24

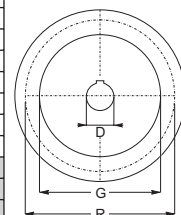

4.0 Type de Moteur / Code STM

4.0 Tipo Motor / Código STM

4.0 Tipo Motor / Código STM

Hydraulic Motor		Input Gearbox			
Company	Motor Type	D	G	R	Code STM
REXROTH	A6VM 80	N40x2	140	180	HB24
REXROTH	A6VM 160	N45x2	180	224	LA25
REXROTH	A10FM 37-45	16/32-15	101,6	146	EA16
REXROTH	A2FM 160	N50x2	180	224	LA26
REXROTH	A6VM 160	N50x2	180	224	LA26
REXROTH	A2FM 200	N50x2	200	250	MA26
REXROTH	A6VM 107	N45x2	160	200	KB25
REXROTH	A6VM 250	N50x2	200	250	MA26
SAE STANDARD	SAE A	25	82,55	106,4	CA4
SAE STANDARD	SAE A	25,4	82,55	106,4	CA5
SAE STANDARD	SAE A	31,75	82,55	106,4	CA6
SAE STANDARD	SAE A	1"6B	82,55	106,4	CA9
SAE STANDARD	SAE C	12/24-14	127	162	GA12
SAE STANDARD	SAE C	12/24-17	127	162	GA14
SAI	GM05-40-200	28x34	125	160	NA29
SAI	GM05-40-200	N35x2	125	160	NA23
SAI	GM2-200-630	36x40	150	250	OA31
SAI	GM1-100-320	28x34	175	210	PA29
SAI	GM1-100-320	N35x2	175	210	PA23
SAMHYDRAULIK	BG 40-400	25	82,55	106,4	CA4
SAMHYDRAULIK	AGC 50-400	25	82,55	106,4	CA4
SAMHYDRAULIK	AGF 50-400	25	82,55	106,4	CA4
SAMHYDRAULIK	AR 50-400	25	82,55	106,4	CA4
SAMHYDRAULIK	ARC 50-400	25	82,55	106,4	CA4
SAMHYDRAULIK	ARF 50-400	25	82,55	106,4	CA4
SAMHYDRAULIK	BR 50-400	25	82,55	106,4	CA4
SAMHYDRAULIK	BG 40-401	25,4	82,55	106,4	CA5
SAMHYDRAULIK	AGC 50-401	25,4	82,55	106,4	CA5
SAMHYDRAULIK	AR 50-401	25,4	82,55	106,4	CA5
SAMHYDRAULIK	ARC 50-401	25,4	82,55	106,4	CA5
SAMHYDRAULIK	BR 50-401	25,4	82,55	106,4	CA5
SAMHYDRAULIK	BR 50-402	31,75	82,55	106,4	CA6
SAMHYDRAULIK	AGC 50-402	32	82,55	106,4	CB7
SAMHYDRAULIK	AGS 50-402	32	82,55	106,4	CB7
SAMHYDRAULIK	ARC 50-402	32	82,55	106,4	CB7
SAMHYDRAULIK	BR 50-403	32	82,55	106,4	CB7
SAMHYDRAULIK	HPR 80-401	32	82,55	106,4	CB7
SAMHYDRAULIK	AGS 50-404	12/24-14	82,55	106,4	CB12
SAMHYDRAULIK	HPR 80-402	12/24-14	82,55	106,4	CB12
SAMHYDRAULIK	H1C 55	12/24-17	127	162	GA14
SAMHYDRAULIK	H1C 226 M	N50x2	200	250	MA26
SAMHYDRAULIK	BG 40-402	1"6B	82,55	106,4	CA9
SAMHYDRAULIK	AR 50-402	1"6B	82,55	106,4	CA9
SAMHYDRAULIK	BR 50-404	1"6B	82,55	106,4	CA9
SAMHYDRAULIK	H1C 75	N35x2	140	180	HB23
SAMHYDRAULIK	H1C 90	N40x2	160	200	KB24
SAMHYDRAULIK	H1C 160 M	N45x2	180	224	LA25
SAMHYDRAULIK	H2V 160 M	N45x2	180	224	LA25
SAMHYDRAULIK	H1C 160 M	45	180	224	LB33
SAUER	51V 080	12/24-14	127	162	GA12
SAUER	90M 031	16/32-15	101,6	146	EA16
SAUER	90M 043	16/32-15	101,6	146	EA16
SAUER	SMF2 033-070	16/32-21	127	162	GA17
SAUER	90M 055	16/32-21	127	162	GA17
SAUER	90M 075	16/32-21	127	162	GA17
SAUER	SMF2 089	16/32-23	127	162	GA27
SAUER	51V 081	16/32-23	127	162	GA27
SAUER	90M 100	16/32-23	127	162	GA27
SAUER	M25MF	16/32-13	101,6	146	EA15
SAUER	M35MF	16/32-13	101,6	146	EA15
SAUER	M44MF	16/32-13	101,6	146	EA15
SAUER	M46MF	16/32-13	101,6	146	EA15
SAUER	90M 030	16/32-13	101,6	146	EA15
SAUER	90M 042	16/32-13	101,6	146	EA15
SAUER	51V 160/A	8/16-13	152,4	228,5	JA20
SAUER	OMT 160-500	40	127	162	GC8
VOAC	0	12/24-14	127	162	GA12
VOAC	0	12/24-14	127	162	GA12
VOAC	V12-60 SAE	12/24-14	127	162	GA12
VOAC	V12-80 SAE	12/24-14	127	162	GA12
VOAC	F12-80 SAE	12/24-17	127	162	GA14
VOAC	0	16/32-13	101,6	146	EA15
VOAC	F12-30 ISO	N30x2	100	125	DB22
VOAC	F12-60 ISO	N35x2	125	160	FA23
VOAC	F12-80 ISO	N40x2	140	180	HB24
VOAC	V14-160	N45x2	180	224	LA25
VOAC	F 12/40 ISO	N32x2	125	160	FA28
VOAC	F12/110 ISO	N45x2	160	200	KB25
WHITE	RS-03-24	25	82,55	106,4	CA4
WHITE	HB-03-24	25	82,55	106,4	CA4
WHITE	RS-03-24	25,4	82,55	106,4	CA5
WHITE	HB-03-24	25,4	82,55	106,4	CA5
WHITE	HB-03-24	31,75	82,55	106,4	CA6
WHITE	HB-03-24	32	82,55	106,4	CB7
WHITE	RS-03-24	1"6B	82,55	106,4	CA9
WHITE	HB-03-24	1"6B	82,55	106,4	CA9
WHITE	HB-03-24	16/32-13	82,55	106,4	CA15

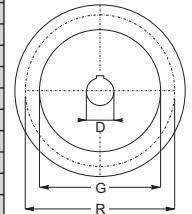

D



## Input Shaft - ECE

*ECE - with solid input shaft*

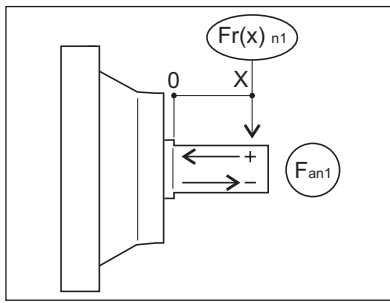
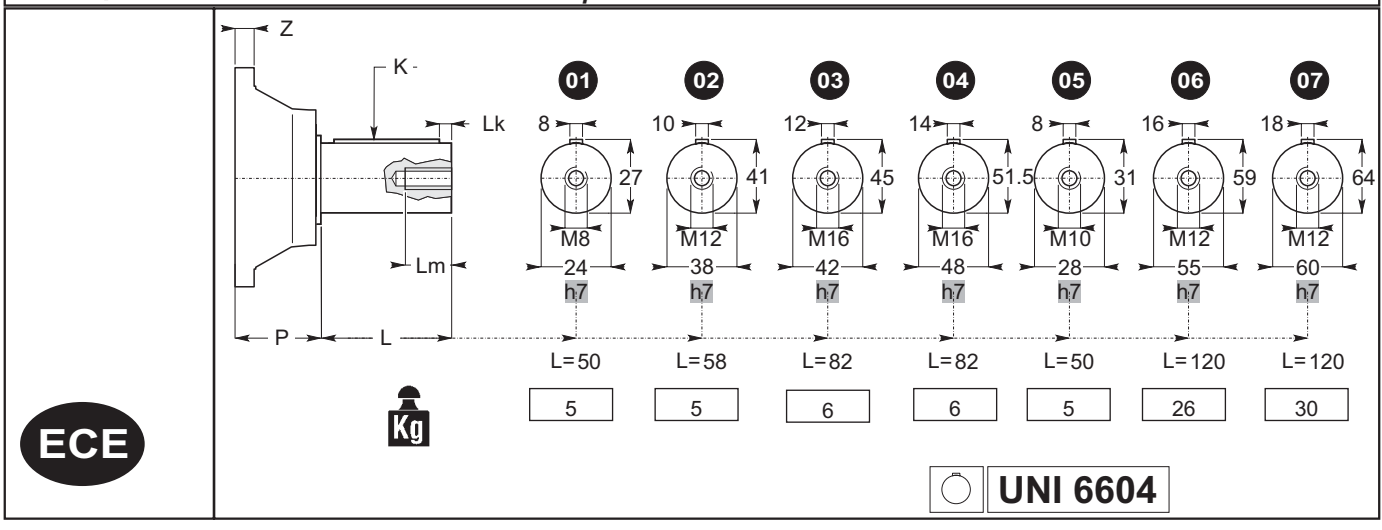
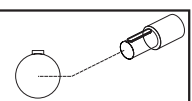

	L	Z	Lm	LK	K	Fa <sub>n1</sub> - Direction	
						(+)	(-)
ECE 1A	50	23	20	5	8x7x40	*	*
ECE 1B	50	23	20	5	8x7x40	*	*
ECE 2A	58	23	24	4	10x8x50	*	*
ECE 2B	58	23	24	4	10x8x50	*	*
ECE 3	82	23	32	6	12x8x70	*	*
ECE 4	82	23	32	6	14x9x70	*	*
ECE 5A	50	23	22	5	8x7x40	*	*
ECE 5B	50	23	22	5	8x7x40	*	*
ECE 6	120	-	30	10	16x10x100	*	*
ECE 7	120	-	30	10	18x11x100	*	*

\*Contacter notre bureau technico-commercial / \* Contactar con nuestra oficina técnica comercial / \* Contactar o nosso departamento técnico comercial

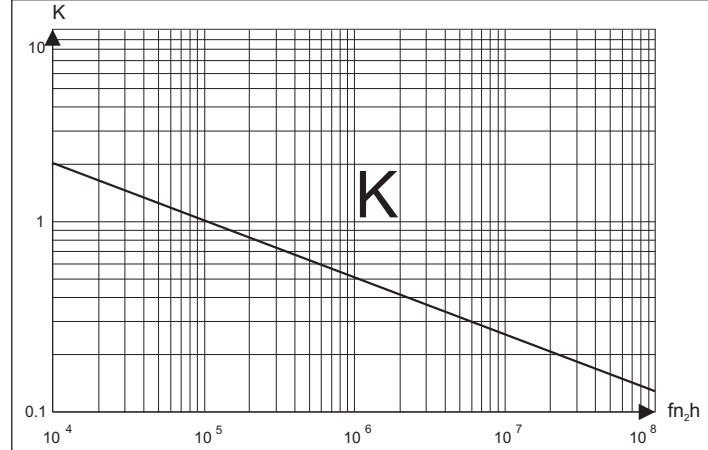
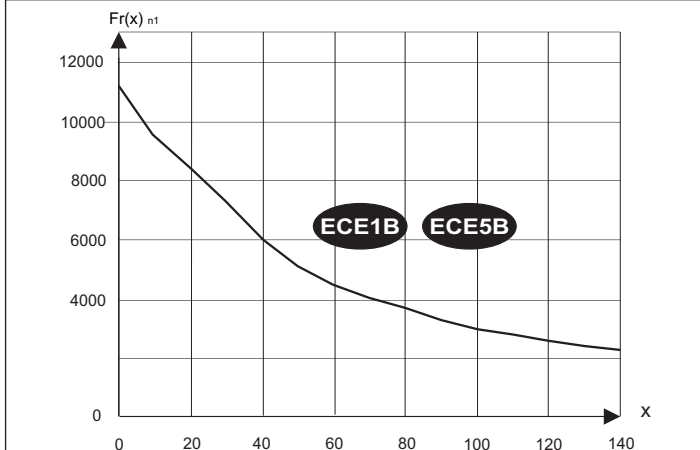
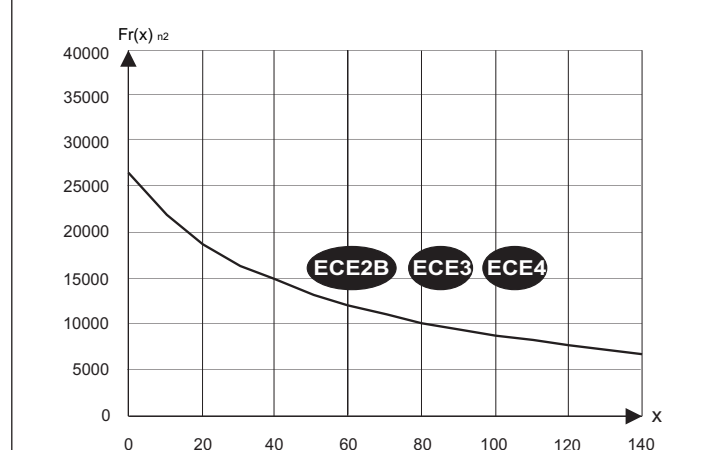
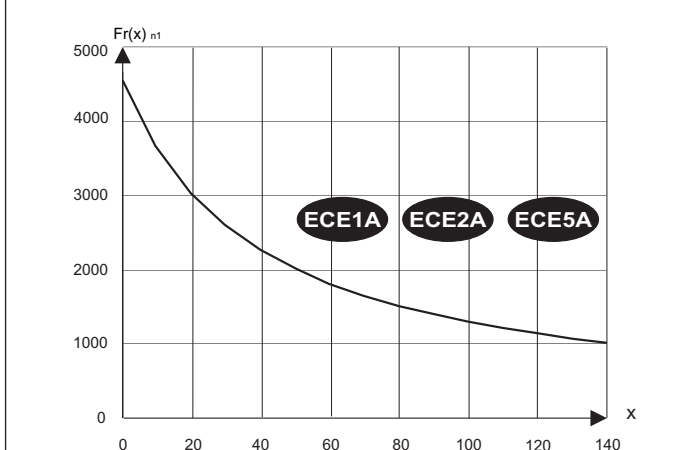

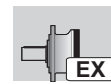

	EX1			EX2 EXB2			EX3 EXB3			EX4 EXB4		
	EX 101→ 1001			EX 102→3502			EX 103→ 15003			EX 104→ 37004		
				EXB 102→ 3002			EXB103→ 10003			EXB 104→31004		
10	101			102			103			104		
20	201			202			203			204		
25	251			252			253			254		
30		301		302			303			304		
35		351		352			353			354		
40				402			403			404		
50		501		502			503			504		
70		701		702			703			704		
80			801		802		803			804		
90					902		903			904		
95					952		953			954		
100			1001		1002		1003			1004		
150					1502		1503			1504		
180					1802		1803			1804		
200					2002		2003			2004		
250						2502		2503		2504		
280						2802		2803		2804		
300						3002		3003		3004		
350						3502		3503		3504		
360								3603		3604		
420								4203		4204		
600								6003		6004		
650								6503		6504		
800								8003		8004		
850								8503		8504		
1000								10003		10004		
1200								12003		12004		
1500								15003		15004		
1600										16004		
2000												20004
2500												25004
2600												26004
3000												30004
3100												31004
3200												32004
3700												37004
4500												
5500												
6800												
7500												
8000												

ECE 1A	91			91			91			91		
ECE 1B		117			117			117			117	
ECE 2A	91			91			91			91		
ECE 2B		117			117			117			117	
ECE 3		117	161,9		117	161,9		117	161,9		117	161,9
ECE 4		117	161,9		117	161,9		117	161,9		117	161,9
ECE 5A	91			91			91			91		
ECE 5B		117			117			117			117	

LOOK AT  
D7

P - [mm]

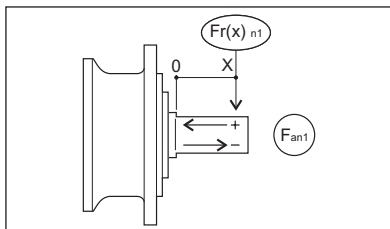
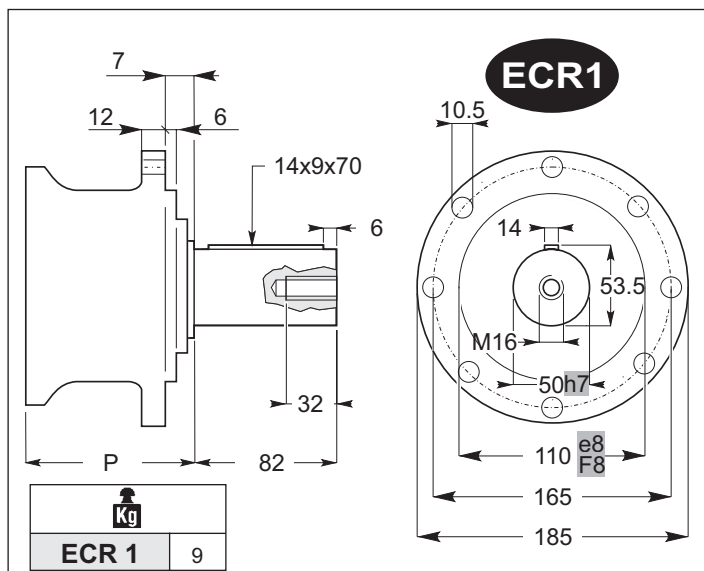
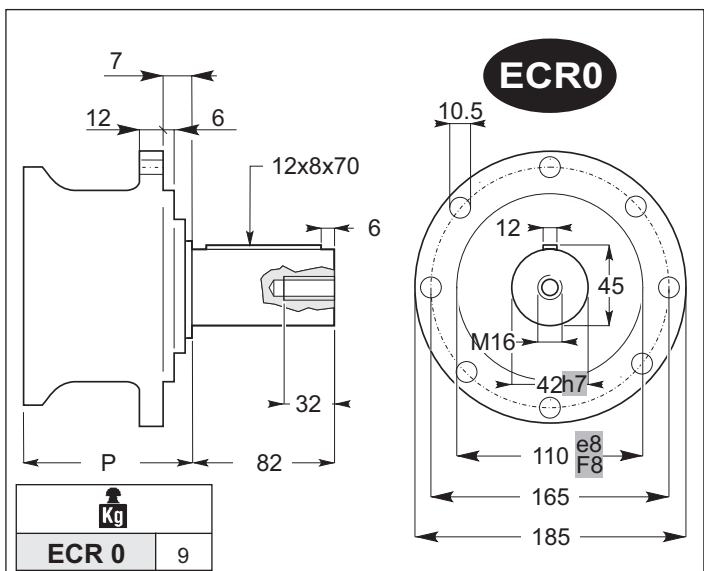

	Diretion/Dirección/Direção	<b>ECR 0</b>	<b>ECR 1</b>
$Fa_{n1}$	(+)	22491	22491
	(-)	19278	19278

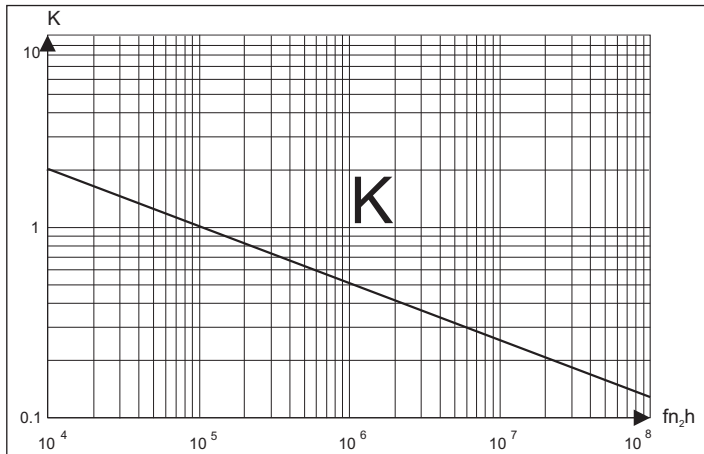
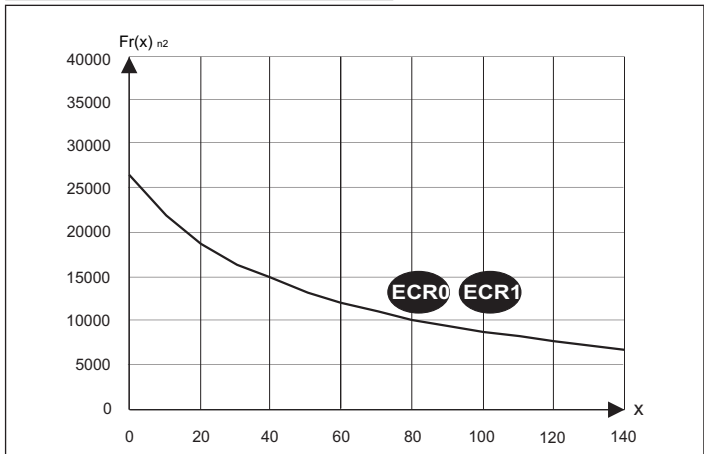

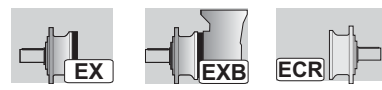

	EX1		EX2 EXB2		EX3 EXB3		EX4 EXB4	
	EX 101→701		EX 102→2002		EX 103→6003		EX-EXB 104→16004	
10	101		102		103		104	
20	201		202		203		204	
25	251		252		253		254	
30		301	302		303		304	
35		351	352		353		354	
40			402		403		404	
50		501	502		503		504	
70		701	702		703		704	
80				802	803		804	
90				902	903		904	
95				952	953		954	
100				1002	1003		1004	
150				1502	1503		1504	
180				1802	1803		1804	
200				2002	2003		2004	
250					2503		2504	
280					2803		2804	
300					3003		3004	
350					3503		3504	
360					3603		3604	
420					4203		4204	
600					6003		6004	
650							6504	
800							8004	
850							8504	
1000							10004	
1200							12004	
1500							15004	
1600							16004	
2000								
2500								
2600								
3000								
3100								
3200								
3700								
4500								
5500								
6800								
7500								
8000								

<b>ECR0</b>	115,3	123,8			115,3	123,8			115,3	123,8		
<b>ECR1</b>	115,3	123,8			115,3	123,8			115,3	123,8		

P - [mm]

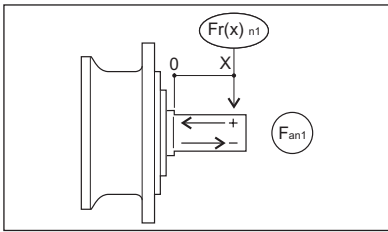
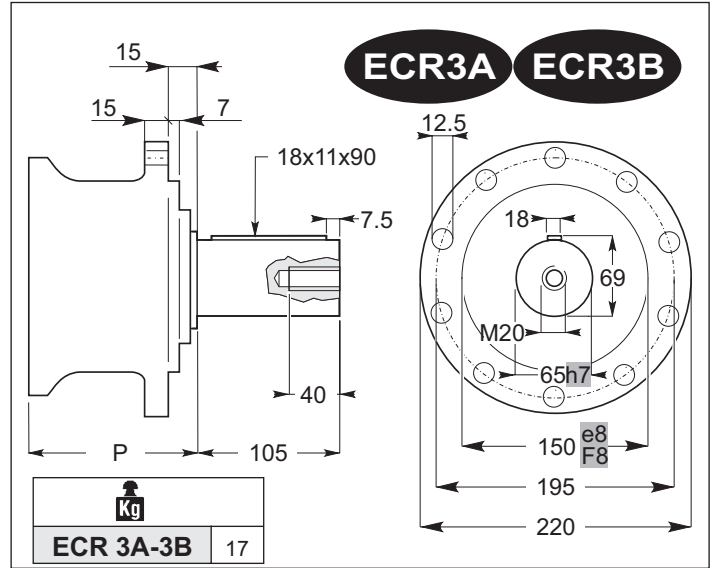
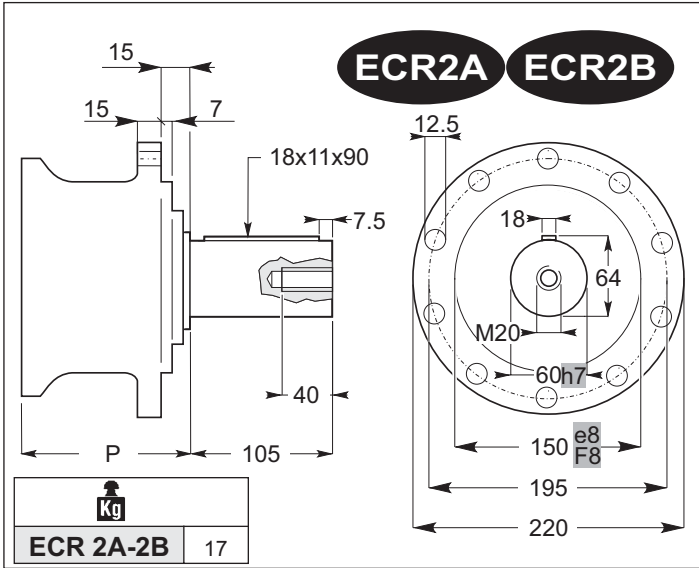

	Diretion/Dirección/Direção	ECR 2A	ECR 3A	ECR 2B	ECR 3B	ECR 4
Fa n1	(+)	34426		38557		44398
	(-)	22491		34426		38557

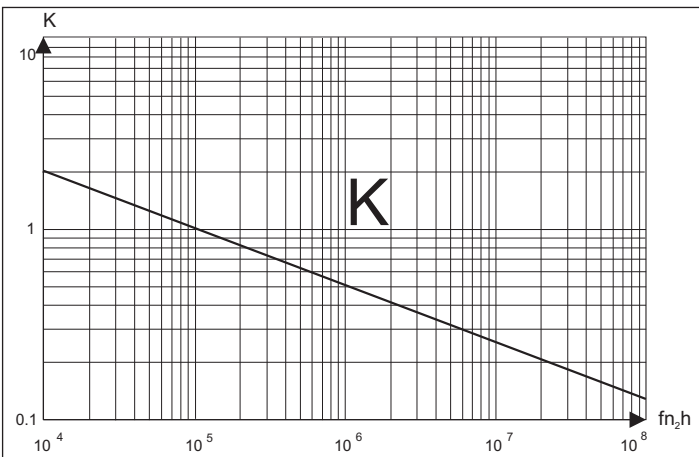
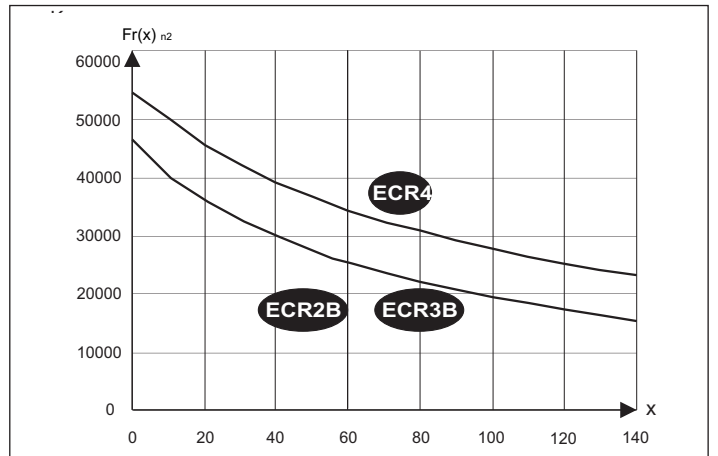
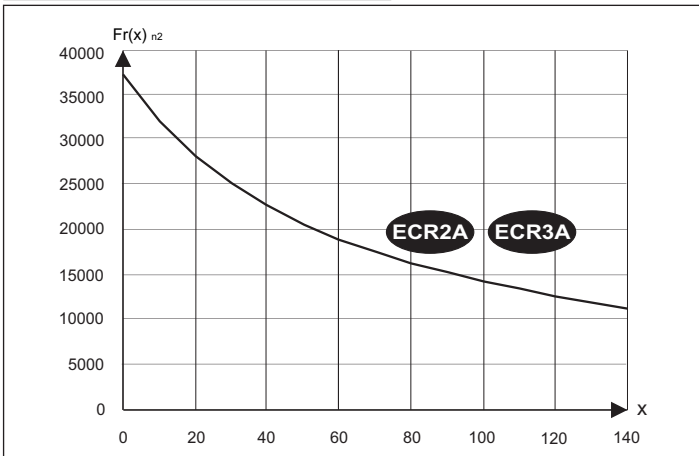



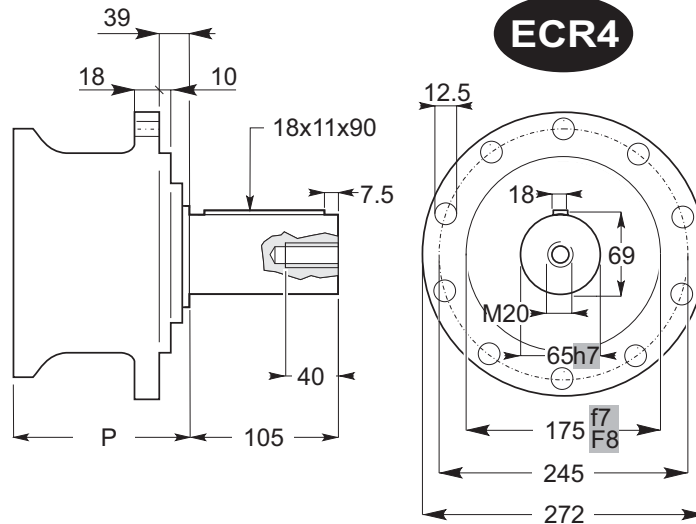

**ECR4**

<b>ECR 4</b>	26

	EX 101→2001				EX 102→ 6002				EX 103→ 16003				EX 104→ 45004			
					EXB 102→3002				EXB 103→ 10003				EXB 104→ 31004			
10	101				102				103				104			
20	201				202				203				204			
25	251				252				253				254			
30		301			302				303				304			
35		351			352				353				354			
40					402				403				404			
50		501			502				503				504			
70		701			702				703				704			
80			801			802			803				804			
90						902			903				904			
95						952			953				954			
100			1001			1002			1003				1004			
150				1501		1502			1503				1504			
180						1802			1803				1804			
200				2001		2002			2003				2004			
250						2502			2503				2504			
280						2802			2803				2804			
300						3002			3003				3004			
350						3502			3503				3504			
360							3602		3603				3604			
420							4202		4203				4204			
600							6002		6003				6004			
650									6503				6504			
800									8003				8004			
850									8503				8504			
1000									10003				10004			
1200									12003				12004			
1500									15003				15003			
1600										16003			16004			
2000															20004	
2500															25004	
2600															26004	
3000															30004	
3100															31004	
3200															32004	
3700															37004	
4500																45004

ECR2A	129,8				129,8				129,8				129,8			
ECR2B		156,5	172,5	180,25		156,5	172,5	180,25		156,5	172,5	180,25		156,5	172,5	180,25
ECR3A	129,8				129,8				129,8				129,8			
ECR3B		156,5	172,5	180,25		156,5	172,5	180,25		156,5	172,5	180,25		156,5	172,5	180,25
ECR4		184,5	200,5	208,25		184,5	200,5	208,25		184,5	200,5	208,25		184,5	200,5	208,25

P - [mm]

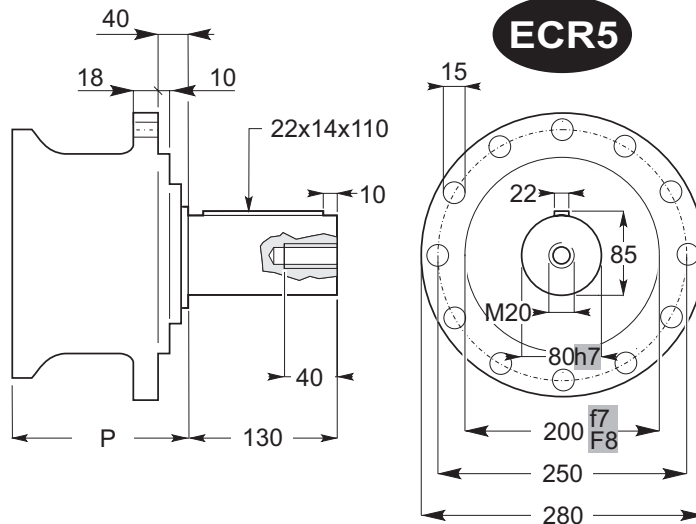

<b>ECR 5</b>	42

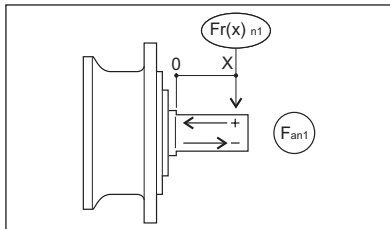

	Diretion/Dirección/Direção	<b>ECR 5</b>
$F_{a_{n1}}$	(+)	58419
	(-)	58419

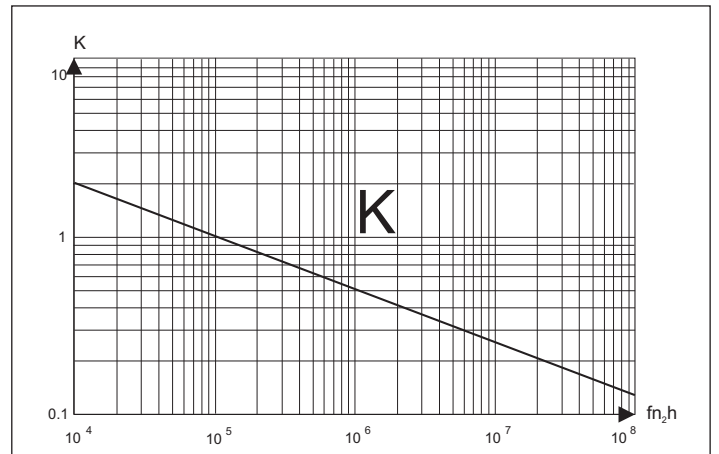
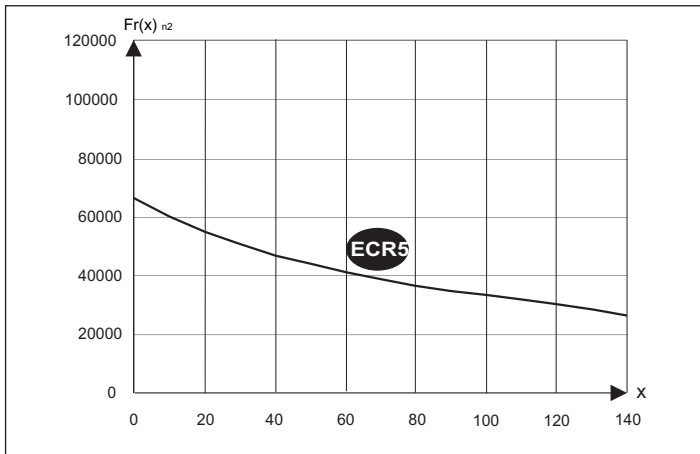



		EX1				EX2 EXB2				EX3 EXB3				EX4 EXB4			
		EX 101 → 3501				EX 102 → 15002				EX 103 → 37003				EX 104 → 80004			
						EXB102 → 3002				EXB103 → 10003				EXB104 → 31004			
<b>80</b>	801																
<b>90</b>																	
<b>95</b>																	
<b>100</b>	1001																
<b>150</b>																	
<b>180</b>																	
<b>200</b>																	
<b>250</b>		2501				2502											
<b>280</b>						2802											
<b>300</b>			3001			3002											
<b>350</b>				3501		3502											
<b>360</b>																	
<b>420</b>																	
<b>600</b>																	
<b>650</b>							6502			6503							
<b>800</b>							8002			8003							
<b>850</b>								8502		8503							
<b>1000</b>								10002		10003							
<b>1200</b>									12002	12003							
<b>1500</b>									15002	15003							
<b>1600</b>																	
<b>2000</b>											20003				20004		
<b>2500</b>											25003				25004		
<b>2600</b>												26003			26004		
<b>3000</b>												30003			30004		
<b>3100</b>													31003		31004		
<b>3200</b>														32003	32004		
<b>3700</b>														37003	37004		
<b>4500</b>																	
<b>5500</b>																55004	
<b>6800</b>																	68004
<b>7500</b>																	75004
<b>8000</b>																	80004

ECR5	194,0		231,4	231,4	291,4	194,0		231,4	231,4	291,4	194,0		231,4	231,4	291,4	194,0		231,4	231,4
P - [mm]																			



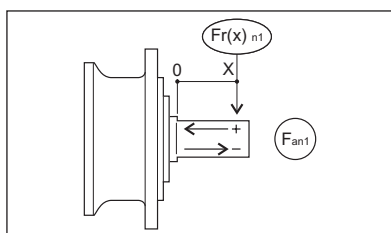
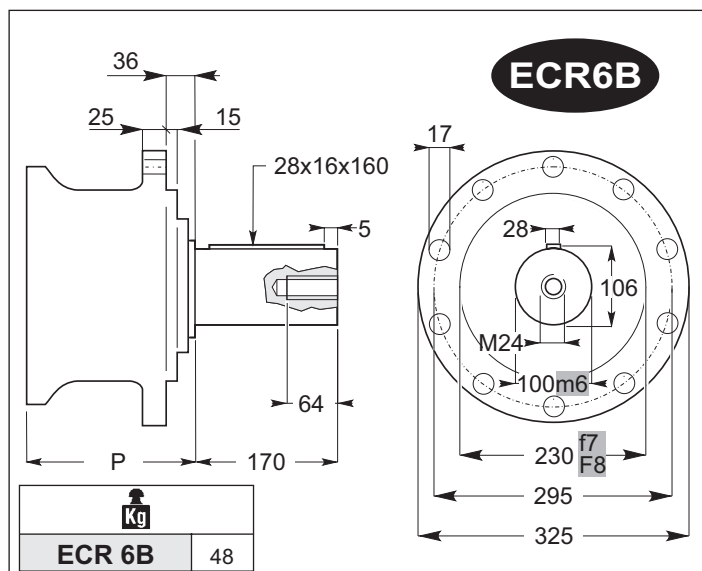
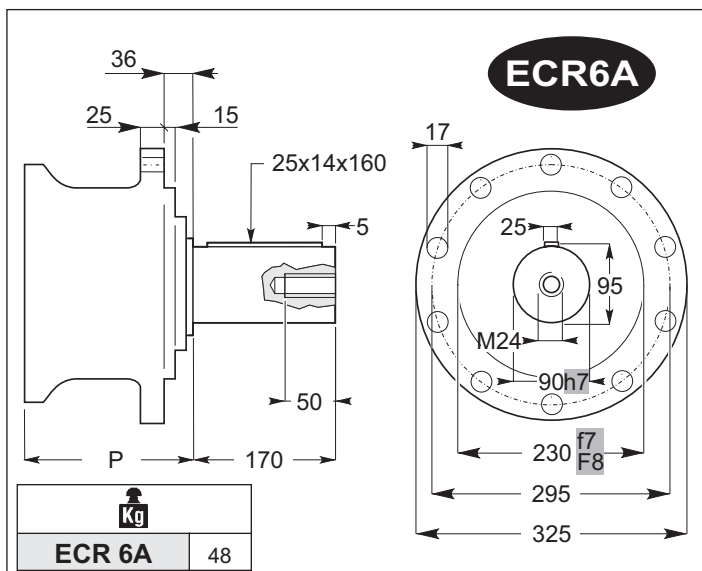

	Diretion/Dirección/Direção	<b>ECR 6A - ECR 6B</b>
$F_{a n1}$	(+)	104737
	(-)	73441

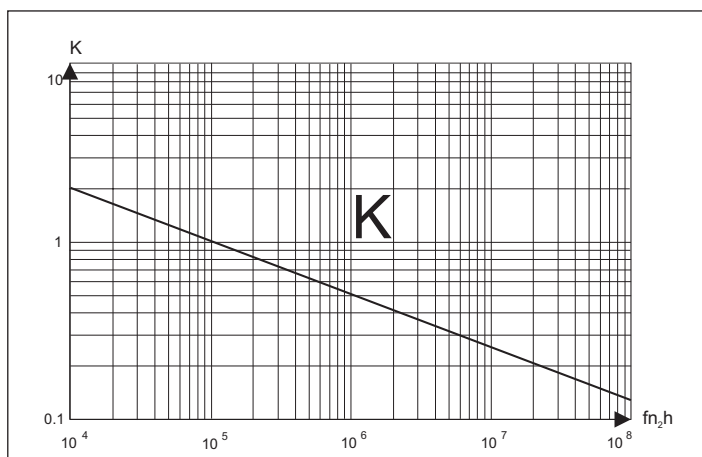
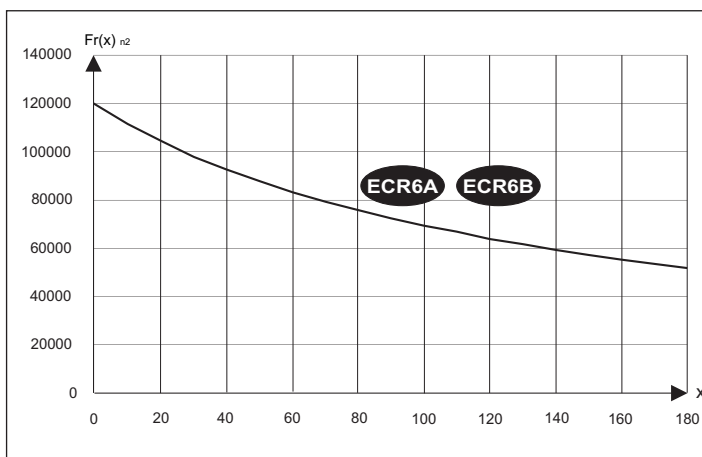

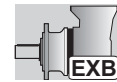

		EX1				EX2 EXB2				EX3 EXB3				EX4 EXB4			
		EX 101 → 3501				EX 102 → 15002				EX 103 → 37003				EX 104 → 80004			
						EXB102 → 3002				EXB103 → 10003				EXB104 → 31004			
80	801																
90																	
95																	
100	1001																
150																	
180																	
200																	
250		2501				2502											
280						2802											
300			3001			3002											
350				3501		3502											
360																	
420																	
600																	
650							6502			6503							
800							8002			8003							
850								8502		8503							
1000								10002		10003							
1200									12002	12003							
1500									15002	15003							
1600																	
2000											20003				20004		
2500											25003				25004		
2600												26003			26004		
3000											30003				30004		
3100												31003			31004		
3200													32003	32004			
3700													37003	37004			
4500																	
5500															55004		
6800																68004	
7500																75004	
8000																80004	

<b>ECR6A</b>	247,4	289,2	289,2	349,2	247,4	289,2	289,2	349,2	247,4	289,2	289,2	349,2	247,4	289,2	289,2
<b>ECR6B</b>	247,4	289,2	289,2	349,2	247,4	289,2	289,2	349,2	247,4	289,2	289,2	349,2	247,4	289,2	289,2

P - [mm]



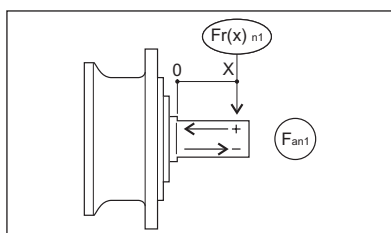
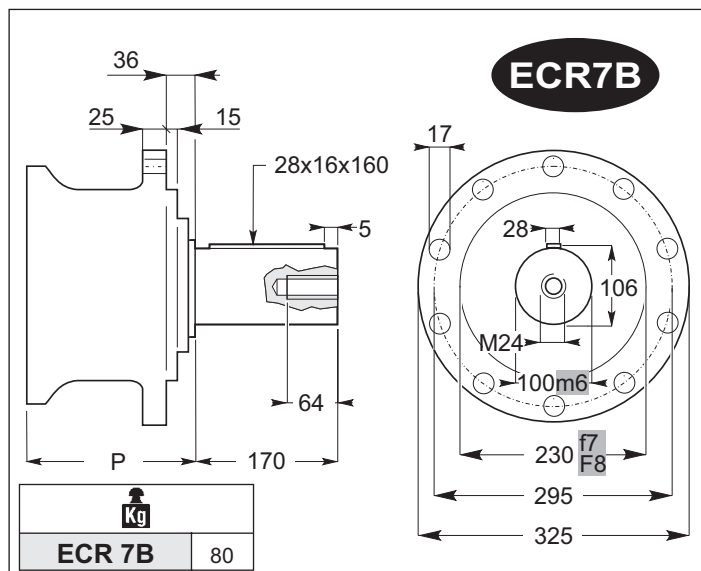
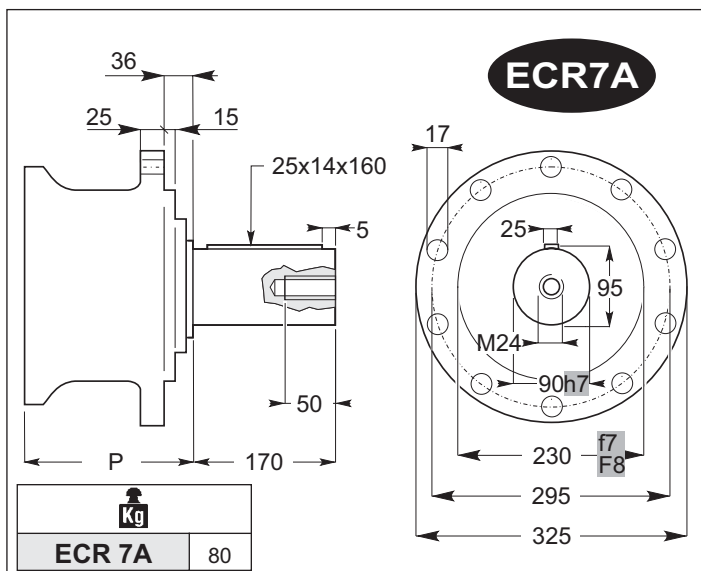

Diretion/Dirección/Direção		<b>ECR 7A - ECR 7B</b>
Fa n1	(+)	104737
	(-)	73441

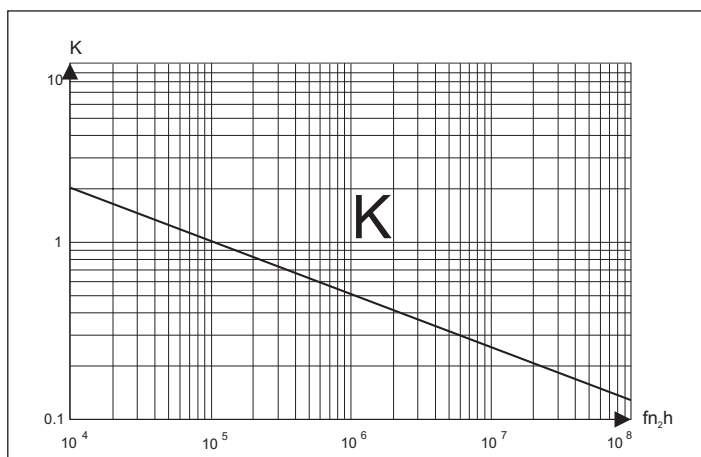
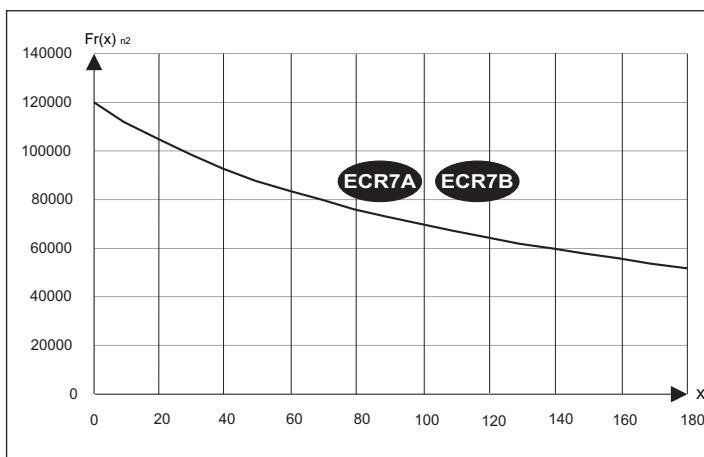



	EX1			EX2			EX3			EX4		
150			1501									
180												
200			2001									
250												
280												
300												
350												
360						3602						
420			4201			4202						
600						6002						
650												
800												
850												
1000												
1200									16003			
1500												
1600						16002						
2000												
2500												
2600												
3000												
3100												
3200												
3700												
4500										45003		45004

ECR7A			255	343,2			255	343,2			255	343,2			255
ECR7B			255	343,2			255	343,2			255	343,2			255

P - [mm]



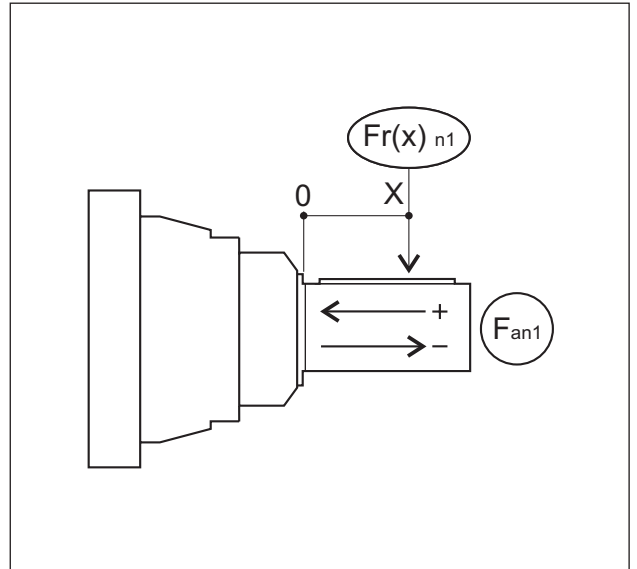
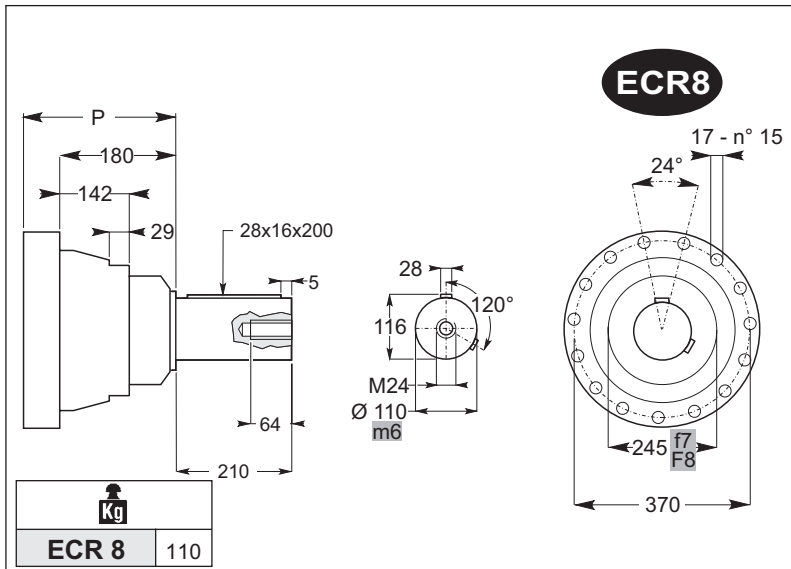

Diretion/Dirección/Direção		ECR 8
Fa n1	(+)	149386
	(-)	112665

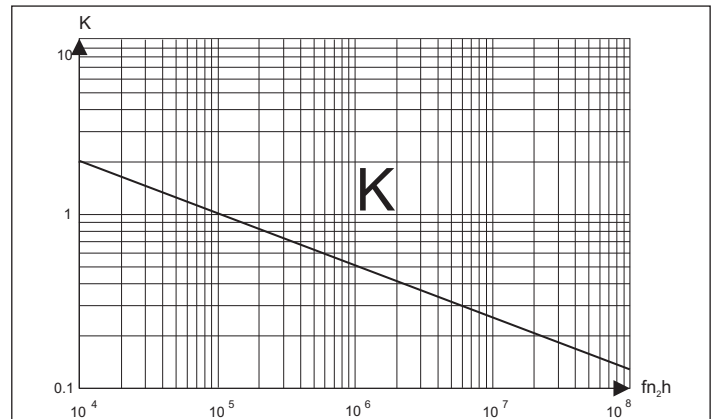
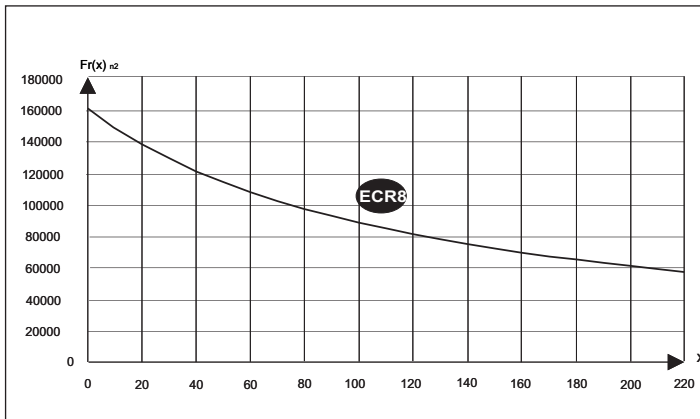

250	2501			
280				
300				
350				
360				
420				
600				
650	6501	6502		
800		8002		
850				
1000				
1200				
1500				
1600				
2000		20002	20003	
2500			25003	
2600				
3000			30003	
3100				
3200				
3700				
4500				
5500				55003
				55004

ECR8	261	362,2	261	362,2	261	362,2	261
------	-----	-------	-----	-------	-----	-------	-----

P - [mm]



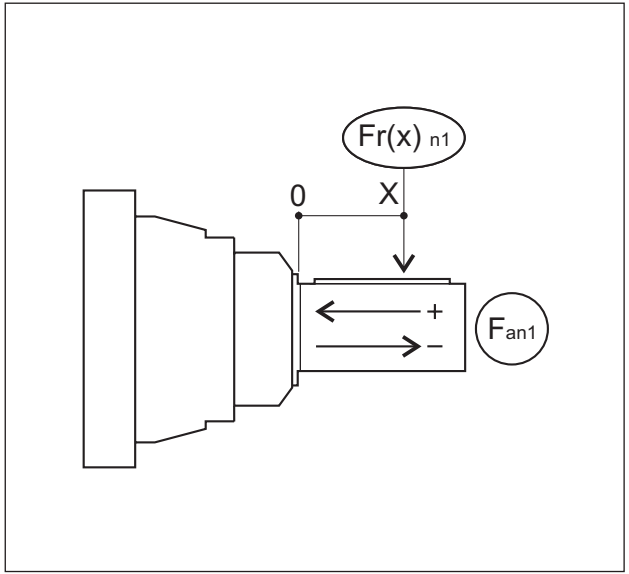
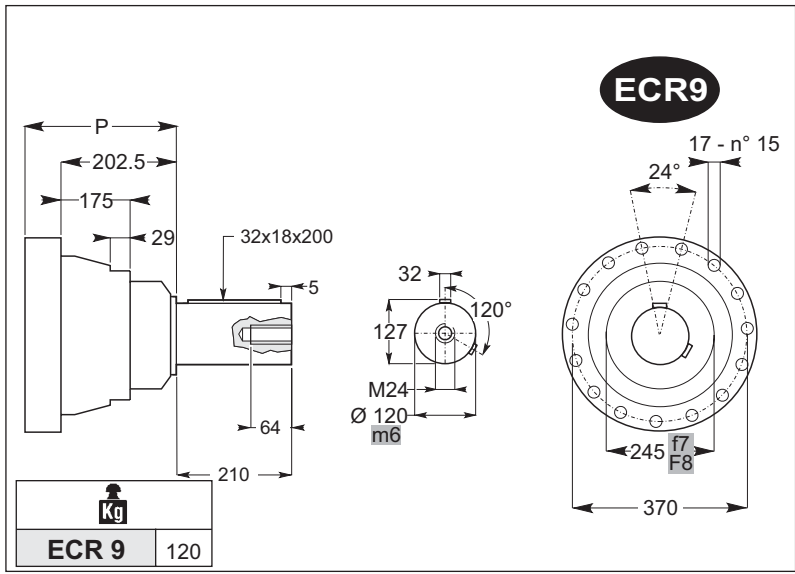

	<i>Diretion/Dirección/Direção</i>	<b>ECR 9</b>
Fa n1	(+)	167746
	(-)	128521

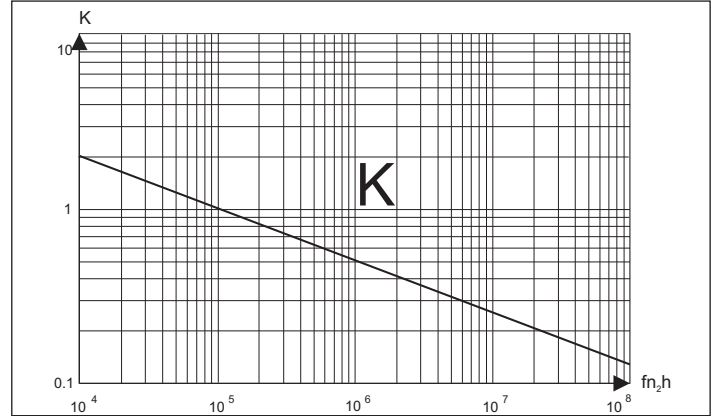
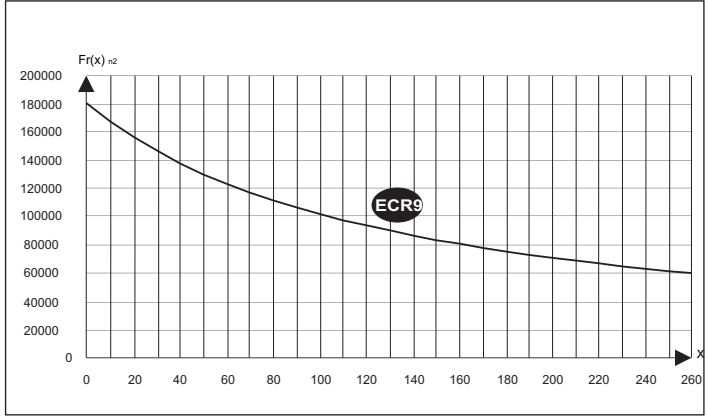

300	3001															
350																
360																
420																
600																
650																
800																
850		8501					8502									
1000			10001				10002									
1200				12001												
1500																
1600																
2000																
2500																
2600							26002				26003					
3000																
3100							31002				31003					
3200										32002						
3700										37002						
4500																
5500																
6800											68003				68004	
7500											75003				75004	
8000												80003			80004	
<b>ECR9</b>	283,5	381,7	373,7	373,7		283,5	381,7	373,7	373,7		283,5	381,7	373,7		283,5	

P - [mm]

EX.

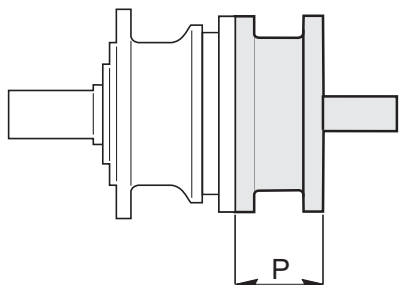

6

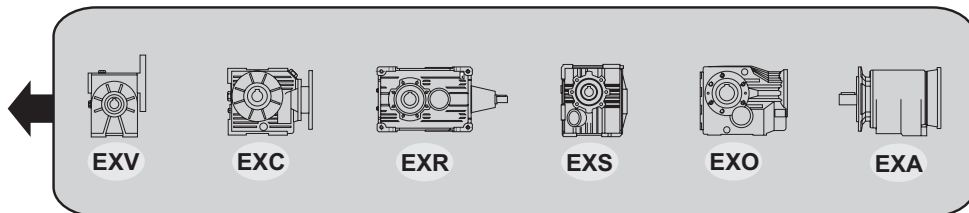

\*Contacter notre bureau technico-commercial / \* *Contactar con nuestra oficina técnica comercial* / \* Contatar o nosso departamento técnico comercial

	<b>1</b>						<b>2</b>						<b>3</b>						<b>4</b>					
10	101						102						103					104						
20		201					202						203					204						
25		251					252						253					254						
30			301				302						303					304						
40							402						403					404						
50			501				502						503					504						
70				701			702						703					704						
80					801		802						803					804						
90							902						903					904						
100					1001		1002					1003					1004							
150					1501		1502					1503					1504							
180							1802					1803					1804							
200						2001				2002			2003				2004							
250							2501				2502			2503				2504						
280											2802				2803			2804						
300							3001				3002				3003			3004						
350											3502				3503			3504						
420												4202				4203			4204					
650													6502			6503			6504					
850													8502				8503				8504			
1200																	1200 3					1200 4		

<b>P</b>																						
EXV 50	*								*								*					*
EXV 63	*								*								*					*
EXV 70	*	*							*	*							*	*			*	*
EXV 85	*	*	*	*					*	*	*	*					*	*	*		*	*
EXV 110			*	*	*	*	*			*	*	*	*	*			*	*	*	*		*
EXV 130			*	*	*	*	*			*	*	*	*	*			*	*	*	*		*
EXV 150				*	*	*	*				*	*	*	*			*	*	*	*		*
EXV 180						*	*				*	*	*	*			*	*	*	*		*
EXC 50	*								*								*					*
EXC 70	*	*							*	*							*	*			*	*
EXC 85	*	*	*	*	*	*	*		*	*	*	*	*			*	*	*	*	*	*	*
EXC 110	*	*	*	*	*	*	*		*	*	*	*	*			*	*	*	*	*	*	*
EXS 35	*								*								*					*
EXS 45	*	*							*	*							*	*			*	*
EXR 704	*	*							*	*							*	*			*	*
EXR 708	*	*	*	*	*	*	*		*	*	*	*	*			*	*	*	*	*	*	*
EXR 712	*	*	*	*	*	*	*		*	*	*	*	*	*		*	*	*	*	*	*	*
EXR 716	*	*	*	*	*	*	*		*	*	*	*	*	*		*	*	*	*	*	*	*
EXR 720	*	*	*	*	*	*	*		*	*	*	*	*	*		*	*	*	*	*	*	*
EXO 132	*	*	*	*	*	*	*		*	*	*	*	*	*		*	*	*	*	*	*	*
EXO 150	*	*	*	*	*	*	*		*	*	*	*	*	*		*	*	*	*	*	*	*
EXO 170	*	*	*	*	*	*	*		*	*	*	*	*	*		*	*	*	*	*	*	*
EXO 190	*	*	*	*	*	*	*		*	*	*	*	*	*		*	*	*	*	*	*	*
EXA 35	*	*	*	*	*	*	*		*	*	*	*	*	*		*	*	*	*	*	*	*
EXA 41	*	*	*	*	*	*	*		*	*	*	*	*	*		*	*	*	*	*	*	*
EXA 45	*	*	*	*	*	*	*		*	*	*	*	*	*		*	*	*	*	*	*	*
EXA 50	*	*	*	*	*	*	*		*	*	*	*	*	*		*	*	*	*	*	*	*

\*Contacter notre bureau technico-commercial / \* Contactar con nuestra oficina técnica comercial / \* Contactar o nosso departamento técnico comercial

