



RXP/800/CR

CR - Series



RIDUTTORI PER CONDENSATORI VENTILATI
 GEAR UNITS FOR AIR COOLED CONDENSERS
 GETRIEBE FÜR LUFTGEKÜHLTEN VERFLÜSSIGER



1.1	Caratteristiche costruttive	<i>Construction features</i>	Konstruktionsmerkmale	B3
1.2	Livelli di pressione sonora SPL [dB(A)]	<i>Mean sound pressure levels SPL [dB(A)]</i>	Schalldruckpegel SPL [dB(A)]	B4
1.3	Criteri di selezione	<i>Gear unit selection</i>	Auswahlkriterien	B8
1.4	Verifiche	<i>Verification</i>	Überprüfungen	B9
1.5	Stato di fornitura	<i>Scope of the supply</i>	Lieferzustand	B16
1.6	Normative applicate	<i>Standards applied</i>	Angewendete Normen	B20
1.7	Designazione	<i>Designation</i>	Bezeichnung	B24
1.8	Lubrificazione	<i>Lubrication</i>	Schmierung	B26
1.9	Prestazioni riduttori	<i>Gear unit ratings</i>	Leistungen der Getrieben	B28
1.10	Momenti d'inerzia	<i>Moments of inertia</i>	Trägheitsmomente	B28
1.11	Dimensioni	<i>Dimensions</i>	Applizierbare Motoren	B34
1.12.1	Estremità d'albero entrata	<i>Input shaft end</i>	Ende der Antriebswelle	B35
1.12.2	Estremità d'albero uscita	<i>Output configuration</i>	Ende der Abtriebswelle	B35
1.13	Accessori	<i>Accessories</i>	Zubehör	B37



RXP-CR - Air cooled condensers

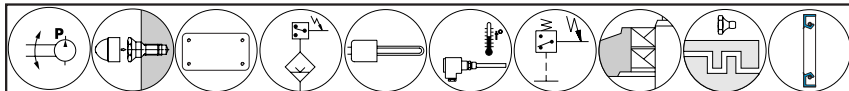

Accessories
and options

Gestione Revisione Cataloghi GSM
 Managing GSM Catalog Revisions
 Mangement Wiederholt Kataloge GSM



RXP/800/CR

CR - Series

RIDUTTORI PER CONDENSATORI VENTILATI
GEAR UNITS FOR AIR COOLED CONDENSERS
GETRIEBE FÜR LUFTGEKÜHLTEN VERFLÜSSIGER

RX CR

STM team

B

STM team

RXP - CR - Series



CR - Application

Air Cooled Condensers



CR - Application

Air Cooled Condensers

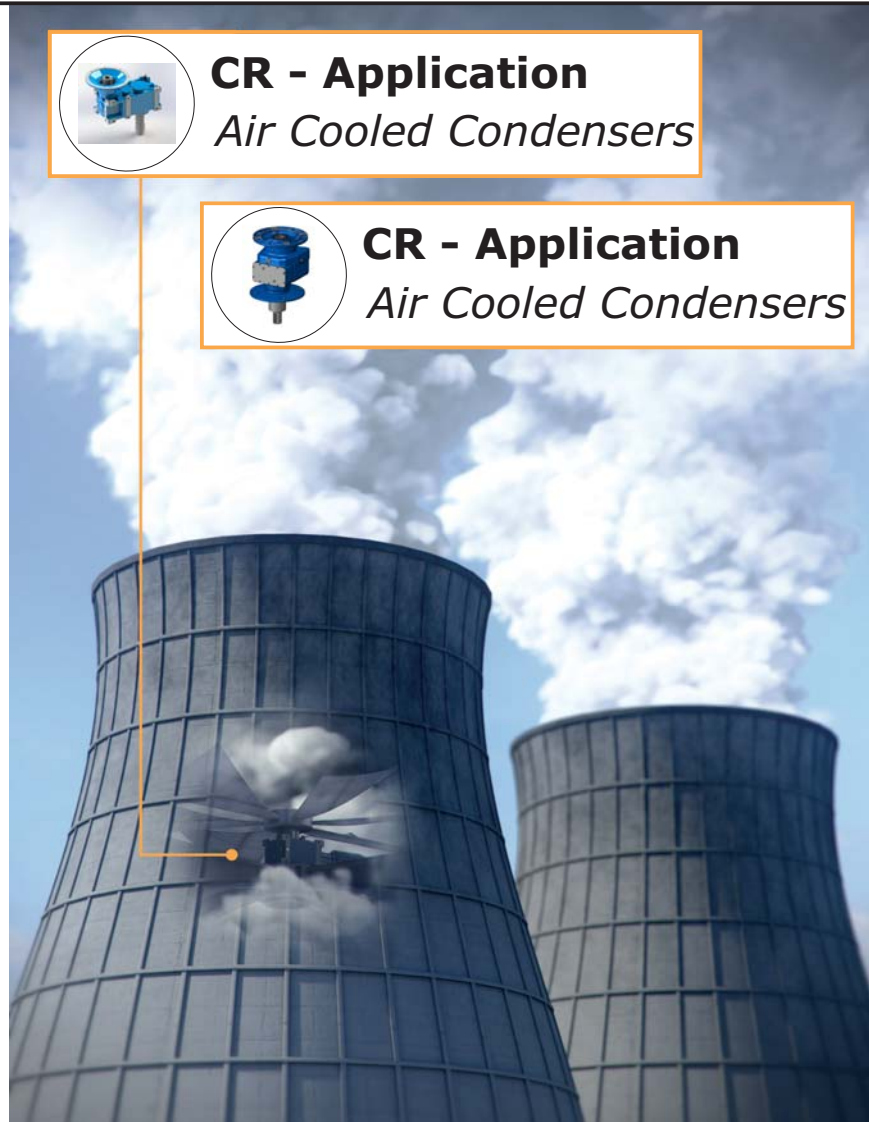

1.0 - Generalità

1.0 General description

1.0 - Allgemeines

Characteristics



Questa serie di riduttori per condensatori ventilati è una macchina che fa dell'affidabilità la sua caratteristica peculiare, gli ingranaggi ed i cuscinetti largamente dimensionati uniti a un'accurata disposizione interna, distribuiscono i carichi uniformemente giovandone alla durata. Avendo anche la cassa divisa a metà, facilitano il controllo periodico e la eventuale manutenzione soprattutto in luoghi poco agevoli.

These gearboxes series for air cooled condensers is especially built to grant reliability to customers. This is made possible through a generous upsizing of both gears and bearings as well as a balanced internal gear arrangement so to offer optimization of uniformity in balancing loads inside the gearbox.

Die Antriebsserie für luftgekühlten verflüssiger and macht die Zuverlässigkeit zu einer ihrer hauptsächlich Eigenschaften. Die großzügig dimensionierten Zahnräder und Lager kombiniert mit sorgfältiger Anordnung des Innenlebens verteilen die Belastungen gleichmäßig, welche sich auf die Lebensdauer positiv auswirkt. Der geteilte Gehäuseaufbau erleichtert di regelmäßige Inspektion und Wartung vor allem an Orten, die nicht einfach zu erreichen sind.

1.1 Caratteristiche costruttive

1.1 Construction features

1.1 Konstruktionsmerkmale

Characteristics

The Series has been designed for the cooling tower and air cooled condensers environment

I riduttore della serie RX per applicazione CR adottano cuscinetti a rulli di elevata capacità di carico maggiormente distanziati sull'albero e un robusto e rigido supporto esterno, in questo modo è consentito un notevole aumento dei carichi radiali e assiali ammissibili. La solidità costruttiva del riduttore consente di inserirsi in un basso regime di severità vibrazionale. I valori sperimentalmente ottenuti sono riassunti nella tabella sottostante.

The RX series gearboxes for CR application adopt roller bearing with high load capacity, with increased center distance on the shaft and a strong and stiff external support, allowing a considerable increase of radial and axial loads.

The stiffness of the gearbox allows to place it in a low span of vibration severity. The values experimentally obtained are summarized in the table below.

Die Getriebe der Baureihe RX für die Anwendung CR setzen Rollenlager mit hoher Tragfähigkeit und mehr Raum zwischen der Welle sowie einer robusten und starren Unterstützung von außen ein; auf diese Art und Weise wird eine erhebliche Erhöhung der Radiallasten und Axialkräfte erlaubt. Die solide Konstruktion ermöglicht das Getriebe in einen niedrigen Vibrationsstärkebereich zu betreiben. Die experimentell erhaltenen Werte sind in der folgenden Tabelle zusammengefasst.

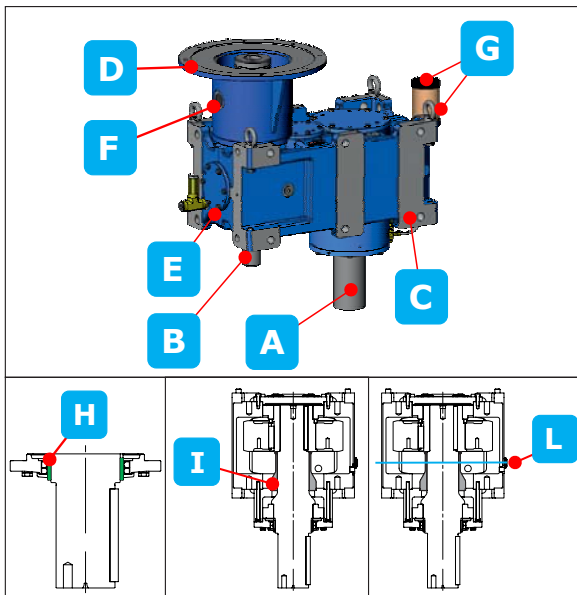

- A Strong radial and axial loads**
- B Forced lubrication**
- C Uniform mounting load to minimize the vibrations**
- D Bell flange and elastic coupling FEM analysis to optimize the flange**
- E Industrial (C5I) and marine (C5M) painting**
- F Service brake**
- G Wet air filter**
- H Lifting eyebolts**
- I Stainless steel ring under the oil seal**
- L DRYWELL with protection cover and double oil seals**
- L Lowered oil level with dry well seals**

Vibration

RXP2 - CR	802	804	806	808	810	812	814	816	818	820
	On request									

Efficiency

RXP2 96

Le dimensioni dei nostri riduttori e i rapporti di trasmissione seguono la serie dei numeri normali (serie di RENARD) Ra 20 UNI 2016. 68.

L'elevato numero di rapporti di trasmissione $i_N = (4 \div 24)$, consente in alcuni casi di scegliere un riduttore di taglia inferiore.

L'ottimizzazione geometrica dell'ingranaggio unitamente ad una accurata lavorazione, assicura bassi livelli di rumorosità e garantisce elevati rendimenti:

Gear unit dimensions and transmission ratios follow a geometric progression based on the Ra20 series of preferred (or Renard) numbers in accordance with UNI 2016.68.

Our broad range of transmission ratios $i_N = (4 \div 25)$ and high ratio density frequently allows selection of a smaller size. Optimal gear geometry and high machining accuracy ensure low noise levels and higher efficiency:

Die Baugrößen und Übersetzungen unserer Getriebe sind der normalen Nummernserie (RENARD Reihe) Ra 20 UNI 2016.68 gemäß ausgelegt.

Die zahlreichen Übersetzungsverhältnisse $i_N = (4 \div 24)$ räumen in einigen Fällen die Möglichkeit ein, ein kleineres Getriebe wählen zu können.

Die geometrische Optimierung des Zahnrads verbunden mit einer akkuraten Bearbeitung gewährleistet niedrige Geräuschentwicklung und einen hohen Wirkungsgrad:

1.2 Livelli di pressione sonora SPL [dB(A)]

1.2 Mean sound pressure levels SPL [dB(A)]

1.2 Schalldruckpegel SPL [dB(A)]

Noise

1 Low Noise

3 ~ 5 db (A)
Noise reduction from previous series

2 FEM analysis

Shaft speed reduction achieved using optimised gear pairs, reducing gear noise. Using FEM analysis, deflection under load is minimized and proper gear tooth contact is maintained. FEM model analysis is also performed to minimize natural frequency oscillation.

Valori normali di produzione del livello medio di pressione sonora SPL (dB(A)) a velocità in entrata di 1450 min⁻¹ (tolleranza +3 db(A)). Valori misurati ad 1 m dalla superficie esterna del riduttore ed ottenuti su elaborazione di prove sperimentali eseguite. Per raffreddamento artificiale con ventola sommare ai valori di tabella: +2 db(A) per ogni ventola. Per entrata ad un numero di giri diverso sommare i valori come in tabella. Per particolari esigenze è possibile fornire riduttori con livello medio di pressione sonora ridotto.

Noise levels are mean sound pressure levels SPL (dB(A)) and refer to normal operation at an input speed of 1450 rpm (tolerance +3 dB(A)). Measurements are taken at 1 m from the external surface of the gear unit and ratings are obtained by processing test data. For fan-cooled applications, add 2dB(A) to table values for each fan. For different input speeds, add the appropriate values indicated in the table below. Gear units with lower noise levels to suit particular needs are available on request.

Normale Werte des durchschnittlichen Schalldruckpegels SPL (dB(A)) bei einer Antriebsdrehzahl von 1450 U/min (Toleranz +3 dB(A)). Werte, die aus den Auswertungen der erfolgten experimentellen Tests, bei denen die Messung in 1 m Entfernung von der Getriebeoberfläche erfolgte, resultieren. Bei Vorliegen einer Zusatzluftkühlung durch Lüfter muss ein Korrekturwert von +2 dB(A) pro Lüfterrad zum Tabellenwert addiert werden. Bei abweichender Antriebsdrehzahl sind die Werte gemäß Tabellenangaben zu addieren. Im Fall besonderer Anforderungen können Getriebe mit einem reduzierten durchschnittlichen Schalldruckpegel geliefert werden.

	RXP2			
	SPL		PWL	
	i ≤ 14	i > 14	i ≤ 14	i > 14
802	75	72	85	82
804	76	73	86	83
806	77	74	87	84
808	78	75	88	85
810	80	77	90	87
812	81	78	91	88
814	83	80	93	90
816	85	82	95	92
818	87	84	97	94
820	89	86	99	96

n ₁ [min ⁻¹]	1750	1000	750	550
Δ SPL [dB(A)]	2	-2	-3	-4
Δ PWL [dB(A)]				

SPL - Lp - sound pressure levels
PWL -Lw - sound power levels

Application



1.3 - Applicazioni

Tra le potenziali applicazioni sulle quali può essere installato il riduttori elenchiamo:

- Condensatori ventilati

1.4 - Potential Application

Potential Applications the following are some of the potential applications on which it is possible to install the gearboxes:

- Air cooled condensers

1.4 - Anwendungen

Unter den möglichen Anwendungen, an denen diese Getriebe installiert werden können, möchten wir folgende aufzählen:

-Luftgekühlten verflüssiger UFTGEKÜHLTEN VERFLÜSSIGER

Accessories

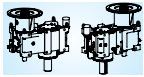

Possono essere forniti i seguenti accessori e dispositivi

Some devices can optionally be provided

Folgende Zubehörteile und Vorrichtungen können geliefert werden:

Designation

- 1** Cooling
- 2** Backstop
- ACC6**
Bearing lubrication
- ACC7.**
- 7A** Vibration Sensor
- 7B** Vibration SWITCH
- 7E** TAP DRAIN
- 7F** Breather with anti-umidity filter
- 7G** OIL LEVEL dipstick
OIL LEVEL SWITCH
- 7H** HEATERS
- 7I** PT 100 - SENSOR
- 7M** Pressure switch
- ACC8**
Sealing

On request

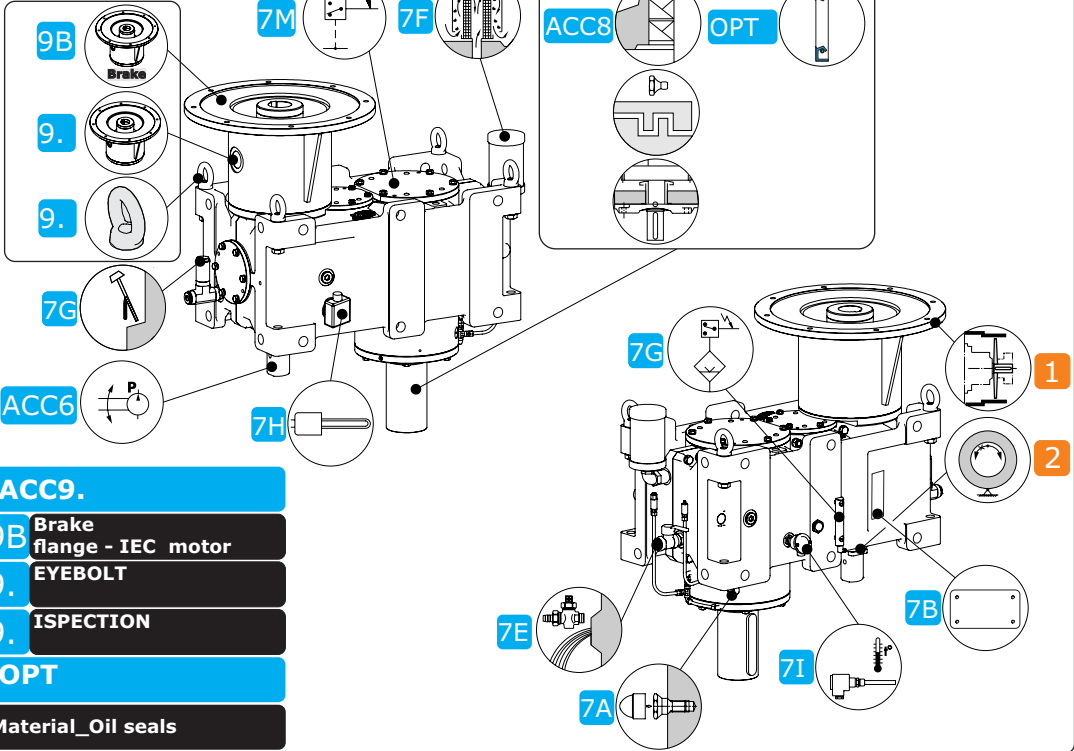

- ACC9.**
- 9B** Brake flange - IEC motor
- 9.** EYEBOLT
- 9.** ISPECTION
- OPT**
Material_Oil seals



Designation

1 Cooling

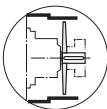

Il calore generato nel riduttore a causa di perdite si può dissipare tramite:
- raffreddamento naturale attraverso la carcassa
- raffreddamento supplementare a mezzo ventilatore assiale azionato tramite asse incorporato nel supporto entrata
Dovrebbe essere sempre garantita l'entrata libera di aria dal lato aspirazione

Heat generated in the gear unit due to losses, can be dissipated by:
- natural cooling through the housing
- additional fan coolingg, shaft driven axial fan incorporated in the lantern housing
Free air entry at the suction side should always be guaranteed

Die im Getriebe aufgrund der Leckagen erzeugte Wärme kann folgendermaßen gestreut werden:
- natürliche Kühlung über den Sitz
- zusätzliche Kühlung über ein Axialgebläse, das von einer im Sitz der Laterne verbauten Achse angetrieben wird
Saugseitig sollte stets der freie Lufteinlass gewährleistet sein

ATEX
Disponibile

ATEX
Available

ATEX
Verfügbar

2 Backstop



I dispositivi antiretro sono forniti con capacità di carico idonea alla prestazine del riduttore. Sono montati direttamente sugli assi pignone. La lubrificazione avviene con olio del riduttore.

Backstops are supplied with appropriate load capacity for gear unit rating. They are fitted directly on the pinion shafts. Lubrication is provided by gear unit oil.

Die Rücklaufschutzvorrichtungen werden mit einer für die Klassifizierung des Getriebes geeigneten Belastungsfähigkeit geliefert. Sind direkt an den Ritzelachsen montiert. Die Schmierung erfolgt durch das Getriebeöl.

ATEX
Disponibile

ATEX
Available

ATEX
Verfügbar

ACC6

Bearing lubrication

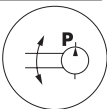

La lubrificazione dei cuscinetti sopra al livello dell'olio è garantita come segue:
- Olio

The lubrication of the bearings above oil level is ensured as follows:
- Oil

Die Schmierung der Lager, über den Öfüllstand hinaus, wird folgendermaßen gewährleistet:
- mit Öl

Per le condizioni di consegna fare riferimento alla sezione specifica.

For the delivery conditions refer to the specific paragraph.

Bezüglich der Lieferbedingungen ist Bezug auf den spezifischen Abschnitt zu nehmen.

Accessories

ACC7.

Possono essere forniti i seguenti accessori e dispositivi

Some devices can optionally be provided:

Folgende Zubehörteile und Vorrichtungen können geliefert werden:

7A Vibration Sensor

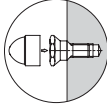

Predisposizione per installazione sensori di vibrazioni. La predisposizione è disponibile sia in ingresso che in uscita

Connection for vibration sensor installation. The connection is available as both input and output

Auslegung für die Installation der Schwingungssensoren. Diese Auslegung ist sowohl am Ein- als auch am Ausgang verfügbar

7B Vibration SWITCH

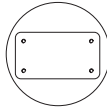

Predisposizione per installazione "Vibration Switch"

Connection for "Vibration Switch" installation

Auslegung für die Installation eines „Vibration Switch“

7E TAP DRAIN

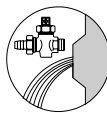

Per facilitare le operazioni di svuotamento del riduttore

To facilitate the gearbox emptying operations

Für eine einfachere Entleerung des Getriebes

7F Breather with anti-umidity filter



Utilizzare un filtro a tre stadi per rimuovere la contaminazione da umidità prima che possano entrare nel riduttore.

Use three-stage filtration to remove moisture solid contamination before they can enter the gearbox.

Verwenden Sie einen dreistufigen Filter, um Feuchtigkeitsverunreinigungen zu entfernen, bevor sie in Getriebe gelangen können.

7G OIL LEVEL dipstick

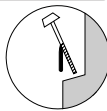

Per controllare il livello dell'olio nel riduttore, può essere fornito una astina di livello per controllo visivo del livello olio.

To control the oil level in the gear unit, an oil level dipstick is provided

Für die Sichtkontrolle des Füllstands des sich im Getriebe befindlichen Öls kann einen Messstab geliefert werden.

7G OIL LEVEL SWITCH

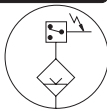

Per controllare il livello dell'olio nel riduttore, può essere fornito uno switch di livello olio. Lo switch può far scattare un allarme quando il livello dell'olio scende al di sotto di un valore specifico

To control the oil level in the gear unit, an oil level switch can be provided. The switch can trigger an alarm signal when the oil level falls beneath a specified

Für die Füllstandkontrolle des sich im Getriebe befindlichen Öls kann ein Ölfüllstandschalter geliefert werden. Dieser Schalter kann einen Alarm auslösen, sobald der Ölfüllstand unter einen bestimmten Wert sinkt

7H HEATERS

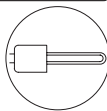

Dispositivi elettrici riscaldamento per avviamenti a basse temperature

Electrical heating devices for low temperature start-up

Elektrische Heizvorrichtungen für Starts bei niedrigen Temperaturen

7I PT 100 - SENSOR

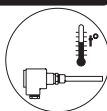

Per controllare la temperatura bagno olio. Il Pt100 può attivare un segnale d'allarme quando la temperatura dell'olio è superiore al limite specificato

To control the oil bath temperature. The Pt100 can trigger an alarm signal when the oil temperature is higher than a specified limit

Für die Kontrolle der Ölumpftemperatur. Der Pt100 kann ein Alarmsignal auslösen, wenn die Öltemperatur über den vorgegebenen Grenzwert ansteigt

7M Pressure switch

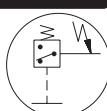

Per controllare la pressione dell'olio, può essere fornito un pressostato / trasmettitore di pressione. Possono attivare un segnale d'allarme quando la pressione scende al di sotto di un limite specifico.

To control the oil pressure, a pressure switch transmitter can be provided. They can trigger an alarm signal when the oil pressure falls beneath a specified limit.

Für die Öldruckkontrolle kann ein Druckschalter / Druckgeber geliefert werden. Diese können ein Alarmsignal auslösen, wenn der Druck unter den vorgegebenen Grenzwert sinkt.

Accessories

ACC8

Sealing

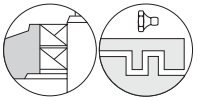

E' possibile richiedere diverse tipologie costruttive per realizzare la tenuta dinamica del riduttore.

It is possible to request various types of manufacturing to ensure the dynamic tightness of the gearbox.

Es können verschiedene Bauarten angefordert werden, um die dynamische Dichtigkeit des Getriebes zu erhalten.

ACC9.

9B Brake flange - IEC motor



Un freno personalizzato può essere fornito su richiesta nella flangia IEC del riduttore.

Custom type of brake can be supplied on request in input IEC flange of gearbox.

Auf Anfrage kann ein kundenspezifischer Bremsentyp im IEC-Eingangsfansch des Getriebes geliefert werden.

9. EYEBOLT



Per facilitare le operazioni di trasporto e movimentazione del riduttore..

To facilitate operations for the transport and movement of the gearbox

Um den Transport und die Bewegung des Getriebes zu erleichtern.

9. INSPECTION



Un tappo può essere fornito su richiesta per controllare il giunto..

A cap can be supplied on request to be checked the joint

Auf Anfrage kann eine Kappe geliefert werden, um die Verbindung zu überprüfen.

OPT

Material_Oil seals

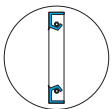

E' possibile richiedere materiali opzionali per gli anelli per la tenuta dinamica del riduttore.

It is possible to request optional materials for the dynamic tightness of gearbox seal rings.

Es können Dichtringe aus optionalen Materialien für die dynamische Dichtigkeit des Getriebes angefordert werden.

Maggiori informazioni sui dispositivi opzionali ACC6-ACC7-ACC8-OPT sono menzionati nella « Sezione U » separata

More detail about the optional devices ACC6-ACC7-ACC8-OPT is mentioned in separate « Section U »

Weitere Informationen zu den optionalen Vorrichtungen ACC6-ACC7-ACC8-OPT werden im getrennten « Abschnitt U » erwähnt



1.3 Criteri di selezione

1.3 Gear unit selection

1.3 Auswahlkriterien

Selection

Conosciuti i dati dell'applicazione calcolare:

$$ir = n_1/n_2 ;$$

$$P1 = \frac{T_{2n} \times n_2 \times 100}{9550 \times RD\%} ;$$

n_1 - Velocità albero entrata;
 n_2 - Velocità albero uscita;
 ir - Rapporto di trasmissione;
 95 - Valore del rendimento dinamico;
 $P1$ - Potenza macchina motrice;

T_{2n} - Coppia Uscita Nominale Applicazione

Per selezionare il riduttore è necessario che sia soddisfatta la seguente relazione:

**Potenza
Power
Leistung**

$$P_N \geq P_1$$

**Coppia
Torque
Drehmoment**

$$T_N \geq T_{2n}$$

Locate application information and determine:

$$ir = n_1/n_2 ;$$

$$P1 = \frac{T_{2n} \times n_2 \times 100}{9550 \times RD\%} ;$$

n_1 - Input shaft speed;
 n_2 - Output shaft speed;
 ir - Ratio;
 95 - Value of dynamic efficiency;
 $P1$ - Input power;
 T_{2n} - Application nominal output torque

For gearbox selection the following is necessary:

Sind die Daten der Anwendung bekannt, ist wie folgt zu kalkulieren:

$$ir = n_1/n_2 ;$$

$$P1 = \frac{T_{2n} \times n_2 \times 100}{9550 \times RD\%} ;$$

n_1 -Drehzahl Antriebswelle;
 n_2 - Drehzahl Abtriebswelle;
 ir - Übersetzung;
 95 - Die Werte der dynamischer Wirkungsgrad;
 $P1$ - Antriebsleistung;
 T_{2n} - Effektivmoment

Für die Getriebeauswahl ist folgendes zu beachten:

1 Fast Selection

Use the chart to find the RX - size based on motor power and fan speed and ratio gearbox.

RXP2_CR		802	804	806	808	810	812	814	816	818	820						
Input Speed [RPM]	Fan speed	389	349	311	277	247	216	192	173	154	140	124	109	99	91	82	74
	ir	4.5	5.0	5.6	6.3	7.1	8.1	9.1	10.1	11.4	12.5	14.1	16.0	17.7	19.3	21.3	23.5
M o t o r p o w e r k W	15.0																
	18.5																
	22.0																
	30.0																
	37.0																
	45.0																
	55.0																
	75.0																
	90.0																
	110.0																
	132.0																
	160.0																
	200.0																
	225.0																
	250.0																
	280.0																
	315.0																
	355.0																
400.0																	
450.0																	
500.0																	
560.0																	
630.0																	
710.0																	
800.0																	
900.0																	
1000.0																	
1120.0																	
1250.0																	
1400.0																	
1600.0																	

Selection



Il valore di T_N è riportato nelle schede tecniche di prodotto.

In quanto membro del "COOLING TECHNOLOGY INSTITUTE" la GSM ha realizzato i riduttori della serie TR in conformità a quanto prescritto dall "CTI CODE TOWER-STD-111 (2009)".

I dati riportati a catalogo non necessitano di essere moltiplicati per ulteriori fattori di servizio per soddisfare alle specifiche di durata e resistenza prescritte nella suddetta norma.

Per n° avviamento/h uguale a 1 non sono necessarie verifiche altrimenti per N° avviamenti/h >1 consultare il nostro servizio tecnico.

Per ulteriori approfondimenti vedere capitolo: "1.6 Normative applicate".

Scegliere il rapporto, la grandezza, l'esecuzione, la forma costruttiva e verificare le dimensioni del riduttore e di eventuali accessori o particolari estremità.

The T_N value is write on the product technical sheets.

As member of the "COOLING TECHNOLOGY INSTITUTE", GSM has developed the TR solution series according the requirements of "CTI CODE TOWER-STD-111 (2009)".

The data listed on the catalogue don't need to be multiplied by additional duty factors to meet specifications of lifetime ans strength requested by above mentioned standard.

If start-up no./h is equal to 1, no test is needed; otherwise, if start-up no./h >1, refer to our technical service.

For further details see chapter: "1.6 Compliance with standards"

Select ratio, size, shaft arrangement and design configuration and then check the dimensions of gear unit and any accessories or particular input/output configurations you have selected.

Den Wert von T_N finden sie auf den technischen Produkt-Datenblättern

Als Mitglied des "COOLING TECHNOLOGY INSTITUTE" hat GSM die Getriebe der TR-Serie in Übereinstimmung mit den Anforderungen von "CTI CODE TOWER-STD-111 (2009)" realisiert.

Die im Katalog angegebenen Daten brauchen nicht mit zusätzlichen Service-Faktoren multipliziert werden um die Spezifikationen der Dauer und Widerstandsfähigkeit in der oben genannten und vorgeschriebenen Norm zu erfüllen.

Bei Anz. Starts/h gleich 1 sind keine Überprüfungen erforderlich, andernfalls ist bei Anz. Starts/h >1 unser Technischer Kundendienst zu Rate zu ziehen.

Für weitere Details siehe Kapitel: "1.6 Einhaltung der Standards".

Die Übersetzung, Größe, Ausführung sowie Bauform wählen und die Größe des Getriebes und des eventuellen Zubehörs oder besondere Wellenenden überprüfen.



1.4 Verifiche

1.4 Verification

1.4 Überprüfungen

01 4) Numero massimo e minimo di giri in entrata $n_{1\ max} - n_{1\ min}$

4) Check maximum and minimum input speed $n_{1\ max} - n_{1\ min}$

4) Max. und Min. Antriebsdrehzahl $n_{1\ max} - n_{1\ min}$

RXP2-CR	Sizes	
$n_{1\ min}$ [rpm]	802-804-806-808-810-812 814-816-818-820	Consultare il ns. servizio tecnico commerciale - <i>Please contact our Sales Engineers -</i> Bitten wir Sie sich mit unseren Technischen Kundendienst in Verbindung zu setzen
$n_{1} < n_{1\ min}$ $n_{1} > 1800$ [rpm]	802-804-806-808-810-812 814-816-818-820	Consultare il ns. servizio tecnico commerciale - <i>Please contact our Sales Engineers -</i> Bitten wir Sie sich mit unseren Technischen Kundendienst in Verbindung zu setzen

1.4 Verifiche

02 2) Verifica carichi radiali e assiali

2.2) Albero uscita

I carichi massimi Fr2 sono calcolati alla distanza "X" indicata in tabella, tali valori sono riportati nelle tabelle delle prestazioni.

1.4 Verification

2) Overhung and thrust load verification

2.2) Output Shaft

Max. Fr2 loads are calculated at the distance shown in the chart, values are listed on the performances charts.

1.4 Überprüfungen

2) Überprüfung der Radial- und Axialkräfte

2.2) Abtriebswelle

Die maximalen Belastungen Fr2 sind mit den in der Tabelle angegebenen Entfernung berechnet, diese Werte sind in den Leistungstabellen dargestellt .

	Size	802	804	806	808	810	812	814	816	818	820
X - [mm]	RXP2-CR	On request									

Fr₂ [N]	Carico radiale ammissibile su albero uscita indicato a catalogo	<i>Output shaft OHL capacity as per catalogue rating</i>	An Abtriebswelle gemäß Katalogangaben zulässige Radialkraft
X [mm]	Distanza dalla battuta dell'albero	<i>Distance from shaft shoulder</i>	Distanz vom Wellenansatz
R [mm]	Sporgenza dell'albero uscita	<i>Output shaft projection</i>	Überstand der Abtriebswelle

Condizioni applicative necessarie

Necessary conditions for application

Erforderliche Einsatzbedingungen

On request



1.4 Verifiche

03 3) Adeguatazza della potenza termica del riduttore:
 Nel caso di solo riduttore in servizio continuo o intermittente gravoso in ambienti a temperatura elevata e/o con difficoltà di scambio termico (es. acciaierie) è necessario verificare che la potenza termica nominale corretta dai fattori sia superiore alla potenza assorbita come evidenziato nella seguente equazione:

1.4 Verification

3) Ensure gear unit thermal power is suitable for the application:
 If a gear unit is to be used in continuous or intermittent duty in environments where high temperatures and/or poor heat exchange are encountered (such as steelworks), check to ensure the thermal power obtained after application of the relevant correction factors is greater than absorbed power, i.e. that the following condition is verified:

1.4 Überprüfungen

3) Angemessene thermische Grenzleistung des Getriebes:
 Wird ein einziges Getriebe im Dauerbetrieb oder harten Schaltbetrieb in einer Umgebung mit hohen Temperaturen und/oder einem schwierigem Wärmeaustausch (z.B. Stahlwerke) eingesetzt, muss geprüft werden, dass die thermische, von den jeweiligen Faktoren korrigierte Nenngrenzleistung über der Aufnahmeleistung liegt, wie es in der folgenden Gleichung dargestellt wird:

$$P_1 \leq P_{tN} \cdot f_a \cdot f_d \cdot f_p \cdot f_f \quad [\text{kW}]$$

Dove:

P_{tN} = potenza termica nominale
 f_a = fattore correttivo dell'altitudine
 f_d = fattore correttivo del tempo di lavoro
 f_p = fattore correttivo della temperatura ambiente
 f_f = fattore correttivo di aerazione con ventola

Where:

P_{ta} = thermal power rating
 f_a = altitude factor
 f_d = operation time factor
 f_p = ambient temperature factor
 f_f = fan cooling factor

Hier ist:

P_{ta} = termische Nenngrenzleistung
 f_a = Höhenkorrekturwert
 f_d = Korrekturfaktor der Arbeitszeit
 f_p = Korrekturfaktor der Umgebungstemperatur
 f_f = Korrekturfaktor der Belüftung durch Lüfter

P_{tN}

Potenza termica nominale
 Thermal power rating
 Termische Nenngrenzleistung

	802	804	806	808	810	812	814	816	818	820
RXP2-CR	30	39	51	66	82	104	127	160	195	252

f_a

Fattore correttivo dell'altitudine
 Altitude factor
 Korrekturwert der Höhe

m	0	750	1500	2250	3000
f_a	1	0.95	0.90	0.85	0.81

f_d

Fattore correttivo del tempo di lavoro
 Operation time factor
 Korrekturwert der Betriebszeit

S3%	100	80	60	40	20
f_d	1	1.05	1.15	1.35	1.8

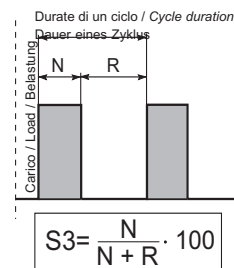

f_p

Fattore correttivo della temperatura ambiente
 Ambient temperature factor
 Korrekturfaktor der Umgebungstemperatur

Temperatura ambiente Ambient temperature Umgebungstemperatur	50 °C	40 °C	30 °C	20 °C	10 °C	0 °C
f_p	0.63	0.75	0.87	1	1.12	1.25

1.4 Verifiche

1.4 Verification

1.4 Überprüfungen

ff

Fattore di aerazione
Aeration factor
Belüftungsfaktor

Il fattore correttivo ff della potenza termica che tiene conto dell'effetto refrigerante della ventola assume in accordo con le norme AGMA 6010.E88 i valori riportati nella tabella. L'impiego è limitato alle velocità maggiori o uguali a 700 min⁻¹.

Cooling fan factors ff reported in table 8 are in accordance with AGMA 6010.E88 and can be used directly to adjust thermal power to reflect the use of a cooling fan. These factors must only be used for speeds equal to 700 rpm and higher.

In Übereinstimmung mit den Normen AGMA 6010.E88 nimmt der Korrekturwert ff der thermischen Grenzleistung, der den Kühleffekt des Lüfters berücksichtigt, die in der Tabelle angegebenen Werte an. Der Einsatz beschränkt sich auf die Drehzahlen die 700 min⁻¹ betragen oder darüber liegen.

ff	Tipo Type Typ	Tipo ventola Fan type Lüfertyp	Note Notes Hinweise
1.7	RXP2-CR	VEM	—

04

4) Condizioni di impiego:

4.1 - $t_a > 0$ °C: vedere i punti 1.8;
4.2 - $t_a < -10$ °C: contattare il nostro servizio tecnico-commerciale.

4) Using conditions:

4.1 - $t_a > 0$ °C: look at points 1.8;
4.2 - $t_a < -10$ °C: contact our technical sales dept.

4) Anwendungsbedingungen:

4.1 - $t_a > 0$ °C: siehe Punkt 1.8;
4.2 - $t_a < -10$ °C: bitte kontaktieren sie unsere technische Verkaufsabteilung.

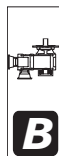

1.4 Verifiche

1.4 Verification

1.4 Überprüfungen

05 5) Coppie antiretro

5) Back-stop device torque

5)Rücklauf-Drehmomente

E' necessario che sia soddisfatta la seguente relazione:

The following ratio must be met:

Folgendes Verhältnis muss gegeben sein

$$T_{1a} > \left(\frac{T_{2r} * 100}{RD * ir} \right)$$

	T _{1a} [Nm]	
802		378
804		463
806		1088
808		1088
810		1219
812		2131
814		3863
816		3863
818		5061
820		8000

T_{2r} = Coppia uscita moto retrogrado;
RD = Valore del rendimento dinamico riduttore;
ir = rapporto riduzione

T_{2r} = output torque retrograde motion;
RD = Value of gearbox dynamic performance;
ir = reduction ratio

T_{2r} = Rückläufiges Abtriebsdrehmoment
RD = Die Werte der dynamischer Getriebewirkungsgrad
ir = Untersetzungsverhältnis

T_{1a} = Coppia limite in ingresso del dispositivo antiretro - [Nm].

T_{1a} = income limit torque for back-stop device - [Nm].

T_{1a} = Grenzantriebsmoment der Rücklaufsperr - [Nm].

06 6) Application Data Sheet

06)Application Data Sheet

06)Application Data Sheet

Qualora le precedenti verifiche non risultino esaustive è necessario rivolgersi al nostro servizio tecnico commerciale compilando il seguente schema:

If the previous tests are not exhaustive please contact our sales department by filling in the following form.

Wenn die oben genannten Tests nicht umfangreich genug sein sollten, ist es notwendig, sich an unsere technische Verkaufsabteilung zu wenden und folgendes Formular auszufüllen:

On request

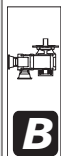

1.5 Stato di fornitura

1.5.1 Protezione alla corrosione e protezione superficiale - RX 800

General information

GSM propone diverse soluzioni protettive opzionali per motori e riduttori che lavorano in speciali condizioni ambientali.
Le misure protettive sono costituite da:
- Protezione corrosiva e protezione superficiale per motori e riduttori;
- Colore Standard RAL 5010

1.5.1.1 - Protezione Corrosiva

La protezione corrosiva è ottenuta con le seguenti specifiche come standard:

- Le targhette sono realizzate in acciaio inox;
- Applicazione di un prodotto anticorrosivo temporaneo per proteggere le superfici di accoppiamento delle flange e gli alberi uscita.

Nel caso di specifiche richieste è possibile applicare tutte le viti di fissaggio in acciaio inox.

1.5.1.2 - Verniciatura e protezione Superficiale

I riduttori preventivamente sabbiati vengono verniciati con vernice ad alto solido, internamente antioil ed esternamente con fondo epossidico anticorrosivo di colore grigio o rosso ricoperto da finitura poliuretana bicomponente di colore Blu RAL 5010 (TYP3).

Nel caso si debbano prevedere impieghi in ambienti industriali più aggressivi o corrosivi o estremi o più genericamente di tipo marino, occorre adottare prodotti adeguati apposti con opportuno ciclo di verniciatura. In questi casi si suggerisce di concordare il ciclo in fase di ordine.

La GSM comunque propone già cicli di verniciatura speciali selezionati per ambienti di questo tipo (TYP4).

1.5 Scope of the supply

1.5.1 - Corrosion and surface protection - RX 800

General information

GSM offers different protective solutions for motors and gearboxes which work in special weather condition
The protective measures are:
- Corrosion and surface protection for motors and gearboxes;
- Standard color RAL 5010

1.5.1.1 - Corrosion protection

The corrosion protection is the result of the following standard procedures:

- The name plates are made of inox steel;
- An anticorrosive temporary product is applied on the mechanized surfaces of flanges and output shafts

In case of special requests it is possible to use inox steel screws

1.5.1.2 - Painting and surface protection

Gearboxes, after being sand blasted, are painted with a specific paint, which has a double function. On the internal side it works as an anti-oil, while on the external side it works as a grey or red anticorrosive epoxy primer covered by a blue RAL 5010 (TYP 3) bi-component polyurethane finishing paint.

In case of use in aggressive or corrosive industrial or sea environments, it is necessary to use special products with the required painting cycle. We suggest you to specify these particular terms with our company.

GSM offers already special painting cycles, which have been created for these kind of environments (TYP 4).

1.5 Lieferzustand

1.5.1 - Korrosionsschutz und Oberflächenschutz - RX 800

Allgemeine Information

GSM bietet optional verschiedene Schutzmöglichkeiten für Motoren und Getriebe an, die in besonderen Umweltbedingungen arbeiten
Die Schutzmaßnahmen bestehen aus:
-Korrosionsschutz und Oberflächenschutz für Motoren und Getriebe;
Standardfarbe RAL 5010

1.5.1.1 - Korrosionsschutz

Der Korrosionsschutz ist bei den folgenden Spezifikationen standardmäßig:

- Die Typenschilder sind aus Edelstahl;
- Anwendung eines temporären Antikorrosionsproduktes als Oberflächenschutz für die Flansch und Abtriebswellenverbindungen

Im Falle spezifischer Anfragen können alle Befestigungsschrauben aus Edelstahl verwendet werden.

1.5.1.2 - Lackierung und Oberflächenschutz

Die vorbeugend sandgestrahlten Getriebe werden mit Farbe mit hohem Feststoffgehalt lackiert, innen gegen das Öl und außen gegen Korrosion mit Epoxid in grauer oder roter Farbe. Und werden abschließend mit Bikomponentenpolyurethan in der Farbe blau RAL 5010 (TYP 3) überzogen..

Sollte der Einsatz in industriellen Bereichen erfolgen, die aggressiver oder korrosiver oder extremer oder allgemein den marinen Bereich betreffen, müssen hierfür geeignete Produkte mit den entsprechenden Lackierzyklen verwendet werden. In diesen Fällen wird vorgeschlagen zuzustimmen.

Die GSM schlägt hier jedoch bereits speziell ausgewählte Lackierzyklen für Bereiche dieser Art vor (TYP4).

Protezione superficiale Surface protection	Numero di strati Permutation of layers	Spessore Coat thickness	Adatto per Suitable for
TYP 3 Industriale <i>Industrial</i>	1x Primer 2x Two-pack Intermediate 1x Two-pack top coat	Circa/Approx. 240 micron A Secco/Dry	1 - Impatto ambientale ALTO - Applicazione industriale <i>High environmental impact - Industrial Application</i> 2 - Umidità relativa massima 100 % <i>Relative humidity max. 100 %</i> 3-Temperatura superficiale massima 120 °C <i>Surface temperature up to max. 120 °C</i> 4 - Categoria di corrosività " C5I-M " (DIN EN ISO 12,944-2) <i>Corrosivity category "C5I-M" (DIN EN ISO 12,944-2)</i>
TYP 4 Marino <i>Marine</i>	1x Zinc Primer 2x Two-pack Intermediate 2x Two-pack top coat	Circa/Approx. 320 micron A Secco/Dry	1 - Alto impatto ambientale - Applicazione ambiente marino <i>High environmental impact - Marine Application</i> 2 - Umidità relativa massima 100 % <i>Relative humidity max. 100 %</i> 3-Temperatura superficiale massima 120 °C <i>Surface temperature up to max. 120 °C</i> 4 - Categoria di corrosività " C5M-M " (DIN EN ISO 12,944-2) <i>Corrosivitycategory "C5M-M" (DIN EN ISO 12,944-2)</i>

A richiesta é possibile fornire ciclo di verniciatura ,schede tecniche dei prodotti utilizzati e report di prova
If requested, we can supply you with painting procedures, data sheets of the products which have been used and testing reports
Auf Anfrage ist es möglich den Lackierzyklus, technische Leistungsblätter der benutzten Produkte und Testberichte zur Verfügung zu stellen

1.5 Stato di fornitura

1.5 Scope of the supply

1.5 Lieferzustand

OPT2 - Opzioni - Verniciatura Options - Painting and surface protection Optionen - Lackierung und Oberflächenschutz					
Serie Series Baureihe	Verniciatura Interna Inner painting Innenlackierung	Verniciatura Esterna Outer painting Außenlackierung		Piani lavorati Machined surfaces Bearbeitete Flächen	Alberi Shafts Wellen
		Tipo e Caratteristiche vernice Paint type and features Lacktyp und -eigenschaften	Verniciabile Can be painted Kann lackiert werden		
TYP 3					
RXP2-CR	fondo epossidico anticorrosivo di colore grigio o rosso Grey or red anticorrosive epoxy primer Epoxidkorrosionsschutz in grauer oder roter Farbe	ricoperto da finitura poliuretanica bicomponente di colore Blu RAL 5010 (TYP3) Covered by a blue RAL 5010 (TYP 3) bi-component polyurethane finishing paint überzogen mit Bikomponentenpolyurethan in der Farbe blau RAL 5010 (TYP 3)	Si	Protetti con prodotto antiruggine. Protected by oxide protectant Mit Rostschutzpaste geschützt.	Protetti con prodotto antiruggine. Protected by oxide protectant. Mit Rostschutzpaste geschützt.

ATTENZIONE
In caso di verniciatura o asportazione del prodotto antiruggine si chiede di porre attenzione alla preventiva protezione:
- Delle superfici lavorate, al fine di evitare che una eventuale verniciatura delle stesse pregiudichi il successivo accoppiamento.
- Delle tenute e più in generale di ogni parte plastica e di gomma, al fine di non variarne le caratteristiche chimico fisiche pregiudicandone così l'efficienza.
- Alla targa di identificazione per evitare la perdita di tracciabilità.
- Al tappo sfiato ed al tappo di livello olio, al fine di evitarne l'occlusione.

ATTENTION
*If the product must be painted or cleaning off any antirust paint, protect the machined surfaces and oil seals/gaskets in order to prevent any damage.
It is also necessary to protect the identification plate, the oil level plug (if fitted) and the hole in the breather plug (if fitted) against obstruction.*

ACHTUNG
Sollten die Produkte lackiert werden oder Abbau des Rostschutzmittels, muss darauf geachtet werden, dass die bearbeiteten und Dichtflächen dabei geschützt werden, so dass verhindert werden kann, dass die Lackierung die chemisch-physischen Eigenschaften verändert und die Wirkung der Ölabdichtungen eingeschränkt. In der gleichen Weise und aus gleichem Grund müssen das Typenschild und die Öleinfüllschraube sowie die Bohrung der Entlüftungsschraube (wo vorhanden) geschützt werden.

1.5.3 MATERIALI COSTRUTTIVI

1.5.3 MATERIAL

1.5.3 KOSTRUKTIONSMATERIAL

1.5.3.1 Casse - Flange - Coperchi

1.5.3.1 Housings - Flanges - Covers

1.5.3.1 Gehäuse - Flanschen - Deckel

Serie Series Baureihe	Per ulteriori informazioni vedere 1.6.5 For more details, please read 1.6.5 Sie können Weitere Informationen siehe 1.6.5
RXP-CR	

1.5.3.2 Materiale degli anelli di tenuta

1.5.3.2 Materials of Seals

1.15.2.2 Dichtungsstoffe

Serie Series Baureihe	OPT Opzioni - Materiale degli anelli di tenuta Options - Materials of Seals Optionen - Dichtungsstoffe	
	(Tenute STANDARD Oil Seals Standard Ölabdichtungen Standard)	Opzioni - Disponibile Options Available Optionen - verfügbar
RXP2-CR	Per ulteriori informazioni vedere SEZIONE U For more details, please read SECTION U Sie können Weitere Informationen siehe ABSCHNITT U	

1.5.4 Lubrificazione

1.5.4 Lubrication

1.5.4 Schmierung

RX	OPT1 - Opzioni - Stato fornitura olio Options - Scope of the supply - Options - OIL Optionen - Lieferzustand - Optionen - Öl	
		Sigla ordine Designation order Bezeichnung Bestellung
all sizes	OUTOIL	

1.5 Stato di fornitura

1.5 Scope of the supply

1.5 Lieferzustand

1.5.4 Lubrificazione

1.5.4 Lubrication

1.5.4 Schmierung

ATTENZIONE:

Lo stato di fornitura è messo in evidenza con una targhetta adesiva posta sul riduttore.

Verificare la corrispondenza tra stato di fornitura e targhetta adesiva.

CAUTION:

Gearbox state of supply is indicated on a nameplate applied on gearbox.







Ensure that nameplate data and state of supply correspond.

ACHTUNG:

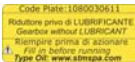
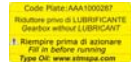
Der entsprechende Lieferzustand wird auf einem Aufkleber am Getriebe angegeben.

Überprüfen Sie die Übereinstimmung zwischen effektivem Lieferzustand und Aufkleber.

**OPT1 - Opzioni - Stato fornitura olio-
Options - Scope of the supply - Options - OIL
Optionen - Lieferzustand - Optionen - Öl**

Stato fornitura <i>Scope of the supply</i> Lieferzustand	Riduttore - Lubrificazione <i>Gearbox - Lubrication</i> Getriebe - Schmierung	Tipo Type Typ	NOTE Note Hinweis	Targhetta <i>Nameplate</i> Aufkleber
OUTOIL Riduttore Privo di Lubrificante <i>Gearbox with no lubricant</i> Getriebe ohne Schmiermittel	Si consiglia l'uso di oli a base sintetica. Vedere a tale proposito le indicazioni riportate paragrafo 1.8. <i>The use of synthetic oil is recommended. see details in paragraph 1.8.</i> Der Einsatz von synthetischem Öl wird empfohlen. Siehe diesbezüglich die Hinweise im Abschnitt 1.8.		Se richiedi completi di lubrificante, verranno forniti con olio standard - "INOIL_STD" <i>If customer requests supply of gearbox with lubricant, we shall supply - "INOIL_STD"</i> Falls diese Getriebe mit Schmiermittelfüllung angefordert werden - "INOIL_STD"	 
INOIL_STD Riduttore Completo di Lubrificante Standard STM <i>Gearbox with lubricant STM standard</i> Getriebe mit Standard Schmiermittel STM	RXP2 CR A richiesta / <i>on request</i> / Auf anfrage ASOIL			On request
INOIL_Food Riduttore Completo di Lubrificante "ALIMENTARE" <i>Gearbox with lubricant "FOOD-TYPE"</i> Getriebe mit Schmiermittel "LEBENSMITTEL"	RXP2 CR A richiesta / <i>on request</i> / Auf anfrage ASOIL			On request
ASOIL Riduttore Completo di Lubrificante Speciale - a richiesta <i>Gearbox with Special lubricant - On request</i> Getriebe mit Sondern-Schmiermittel - Auf Anfrage	A richiesta <i>On request</i> Auf Anfrage	OilGear_TYPE CLP PG Synthetic PG OilGear_TYPE CLP HC Synthetic PAO OilGear_TYPE CLP Mineral OilGear_TYPE CLP HCE Synthetic HCE NSF H1 Grease	—	    

Nota campo- ASOIL

Nella targhetta sono riportate le seguenti informazioni:

- Code_Plate;
- Sigla lubrificante;
- ISO VG;
- Type DIN;
- NSF;
- Altre prescrizioni.

Note range-ASOIL

The type plate contains the following information:

- Code_Plate
- Lubricant type
- ISO VG
- Type DIN
- NSF
- other details

Hinweis Bereich-ASOIL

Auf dem Typenschild finden Sie folgende Informationen:

- Code_Plate
- Schmiermitteltyp
- ISO VG
- Type DIN
- NSF
- andere Hinweise

1.5 Stato di fornitura

1.5 Scope of the supply

1.5 Lieferzustand

1.5.4.2 - Lubrificazione cuscinetti

1.5.4.2 - Bearing lubrication

1.5.4.2 - Schmierung der Abtriebslagerung

Grandezza / Size / Baugröße									
802	804	806	808	810	812	814	816	818	820
LFP2: Pompa - (vedi sezione U accessori e opzioni) LFP2: pump - (see Section U Accessories and Options) LFP2: Pumpe - (siehe Abschnitt U „Zubehör und Optionen“									

La lubrificazione forzata dei cuscinetti superiori è associata alla lubrificazione forzata degli ingranaggi.

Forced lubrication for upper bearings is associated with forced lubrication for the gears.

Die Zwangsschmierung der obenliegenden Lager wird mit der Zwangsschmierung der Zahnräder assoziiert.

1.5.5 Antiretro

1.5.5 Back-stop device

1.5.5 Rücklaufsperr

Qualora sia presente un dispositivo antiretro una freccia ne evidenzia il senso di rotazione consentito.

In the event a back-stop device is provided, an arrow indicates its permitted direction of rotation.

Sollte eine Rücklaufsperr vorhanden sein, wird die zulässige Drehrichtung durch einen Pfeil angegeben.



1.6 Normative applicate

1.6 Standards applied

1.6 Angewendete Normen

1.6.1 Specifiche prodotti non "ATEX"

1.6.1 Specifications of non - "ATEX" products

1.6.1 Spezifikationen für produkte, die nicht der "ATEX"-norm entsprechen

I riduttori della GSM SpA sono organi meccanici destinati all'uso industriale e all'incorporazione in apparecchiature meccaniche più complesse. Dunque non vanno considerati macchine indipendenti per una predeterminata applicazione ai sensi 2006/42/CE, né tantomeno dispositivi di sicurezza.

GSM SpA gearboxes are mechanical devices for industrial use and incorporation in more complex machines. Consequently, they should not be considered neither self-standing machines for a pre-determined application according to 2006/42/CE nor safety devices.

Bei den Getrieben der GSM SpA handelt es sich um Mechanikorgane, die für den industriellen Einsatz und einen Einbau in komplexere Einrichtungen bestimmt sind. Sie werden deshalb weder unter dem Aspekt unabhängiger, für eine bestimmte Anwendung vorgesehener Maschinen im Sinne der 2006/42/CE, noch als Sicherheitsvorrichtungen berücksichtigt.

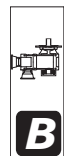

1.6 Normative applicate

1.6 Standards applied

1.6 Angewendete Normen

1.6.2 Specifiche prodotti "ATEX"

1.6.2 Specifications of "ATEX" products

1.6.2 Spezifikationen für "ATEX"-produkte

Campo applicabilità

La direttiva ATEX (2014/34/UE) si applica a prodotti elettrici e non elettrici destinati a essere introdotti e svolgere la loro funzione in atmosfera potenzialmente esplosiva. Le atmosfere potenzialmente esplosive vengono suddivise in gruppi e zone a seconda della probabilità di formazione. I prodotti GSM sono Conformi alla seguente classificazione:

Application field

ATEX set of provisions (2014/34/UE) is referred to electric and non-electric products which are used and run in a potentially explosive environment. The potentially explosive environments are divided into different groups and zones according to the probability of their formation. GSM products are in conformity with following classification:

Anwendungsbereich

Die ATEX-Richtlinie (2014/34/UE) wird bei elektrischen und nicht elektrischen Produkten angewendet, die dazu bestimmt sind, in potentiell explosionsfähigen Atmosphären eingesetzt und betrieben zu werden. Die potentiell explosionsfähigen Atmosphären werden in Abhängigkeit der Wahrscheinlichkeit in Gruppen und Zonen unterteilt. Die GSM-Produkte entsprechen der folgenden Klassifizierung:

Type Mark - standard									
Designation Type Mark	Material	Symbol Mark	Group	Category	Symbol Protection	Group Dangerous material	Temperature	Protection level EPL	Use limitation
Gb-4	GAS		II	2G	Exh	IIC	T4	Gb	-
Gb-5							T5*		
Gc-4			II	3G	Exh	IIC	T4	Gc	-
Gc-5							T5*		
Db-4	DUST		II	2D	Exh	IIIC	135 °C	Db	-
Db-5							100 °C*		
Dc-4			II	3D	Exh	IIIC	135 °C	Dc	-
Dc-5							100 °C**		
ACC6	Lubr.		Lubrication with pump						
ACC7G	Level		On request						
ACC7H	heater								
ACC7I1	Temperature								
ACC7M2	Pressure								

(*) Classe di temperatura ATEX ottenibile a richiesta / ATEX temperature class on request / Auf Anfrage erhältliche ATEX-Temperaturklasse

Type Mark - with limitation						
Limitation	Material	Designation Type Mark	Category	Group Dangerous material	Note	
Products Versions	Versions with compact motor	—	—	—	—	All versions are excluded from certification
Accessory Option	Ventilation system And/Or Painting type: TYP3 - TYP4 *	GAS GAS	b_Gb-4 - b_Gb-5 b_Gc-4 - b_Gc-5	Standard	IIB	*For other type painting: Type Mark is Standard On request in available painting type for IIC: TYP3C & TYP4C
	Ventilation system	DUST DUST	b_Db-4-x - b_Db-5-x b_Dc-4-x - b_Dc-5-x			IIIB

Nel caso di Classe di temperatura T5 occorre verificare la potenza limite termico declassata;

In case of T5 Class of temperature the extreme down-graded thermic power should be checked.

Bei der Temperaturklasse T5 muss die zurückgestufte thermische Grenzleistung überprüft werden.

In tutti gli altri casi vale la potenza riportata a catalogo prevista per i singoli rapporti con fattore di servizio complessivo dell'applicazione pari a 1 e le considerazioni sul limite termico.

In all the other instances, the power indicated on the catalogue for the single ratios with overall application service factor equal to 1 and the considerations on temperature limits apply.

In den anderen Fällen gilt die im Katalog für die einzelnen Übersetzungsverhältnisse angegebene Leistung mit Betriebsfaktor einschließlich Applikation entsprechend 1 und die Berücksichtigungen im Hinblick auf die thermische Grenzleistung.

I prodotti del gruppo IID (atmosfera polverosa) vengono definiti dalla massima temperatura di superficie effettiva.

The products of the family IID (dust environment) are defined by the max effective surface temperature.

Die der Gruppe IID (Atmosphäre mit staubförmiger Belastung) angehörigen Produkte werden ihrer effektiven maximalen Oberflächentemperatur gemäß definiert.

La massima temperatura di superficie è determinata in normali condizioni di installazione e ambientali (-20°C e +40°C) e senza depositi di polvere sugli apparecchi. Qualunque scostamento da queste condizioni di riferimento può influenzare notevolmente lo smaltimento del calore e quindi la temperatura.

Max surface temperature is determined in standard installation and environmental conditions (-20°C and +40°C) and in absence of dust on product surface. Any other condition will modify the heat dissipation and consequently the temperature.

Die maximale Oberflächentemperatur wird in normalen Einbau- und Umgebungsbedingungen (-20°C und +40°C) und ohne auf den Vorrichtungen vorhandenen Staubablagerungen bestimmt. Jegliche Abweichung von diesen Bezugsbedingungen kann sich erheblich auf die Wärmeableitung bzw. auf die Betriebstemperatur auswirken.

1.6.3. COME SI APPLICA

Al momento di una richiesta di offerta per prodotto conforme a normativa ATEX 2014/34/UE occorre compilare la scheda acquisizione dati (www.stmspa.com).

1.6.3. HOW IS IT APPLIED

In case of request of offer relating to any product in conformity with the provisions ATEX/2014/34/UE, the specifications paper should be filled in (www.stmspa.com).

1.6.2. ANWENDUNGSWEISE

Bei einer Angebotsanfrage für der Richtlinie ATEX 2014/34/UE entsprechende Produkte muss das Datenerfassungsformular (www.stmspa.com) ausgefüllt werden.

- Effettuare le verifiche come prima descritto.
- I riduttori certificati verranno consegnati con:
 - una seconda targhetta contenente i dati ATEX;
 - ove previsto un tappo sfiato, tappo sfiato con molla interna;
 - se rispondente alla classe di temperatura T4 e T5 verrà allegato un indicatore di temperatura (132 °C nel caso di T4 e 99°C rispettivamente per la T5)
 - Indicatore di temperatura : termometro a singolo rilevamento, una volta raggiunta la temperatura indicata si annerisce segnalando il raggiungimento di tale limite.

- Perform the inspections as described above. Certified reducers will be delivered with:
 - a second nameplate containing ATEX data;
 - a breather valve with internal spring, where a breather is needed;
 - if in accordance with classes of temperature T4 and T5, a temperature gauge will be included (132 °C in case of T4 and 99 °C in case of T5).
 - Temperature gauge: single-reading thermometer, it blackens once temperature is reached, pointing out the achievement of that limit.

- Dazu die zuvor beschriebenen Kontrollen vornehmen. Die zertifizierten Getriebe werden wie folgt ausgestattet geliefert:
 - mit einem zweiten Typenschild mit ATEX- Daten;
 - wo vorgesehen, mit einem Entlüftungs- verschluss, Entlüftungsverschluss mit interner Feder;
 - falls der Temperaturklasse T4 und T5 entsprechend, wird eine Temperaturanzeige vorgesehen (132 °C bei T4 und 99°C bei T5)
 - Temperaturanzeige: einzelnes Erfassungsthermometer - bei Erreichen der angegebenen Temperatur wechselt die Farbe zur Anzeige der erreichten Temperatur in Schwarz.



1.6 Normative applicate**1.6.4 UE Directive - marcatura CE-ISO9001****Direttiva Bassa Tensione 2014/35/UE**

I motoriduttori, motorivii angolari, motorivariatori e i motori elettrici GSM sono conformi alle prescrizioni della direttiva Bassa Tensione .

2014/30/UE Compatibilità elettromagnetica

I motoriduttori, motoriviiangolari, motorivariatori e i motori elettrici GSM sono conformi alle specifiche della direttiva di Compatibilità Elettromagnetica.

Direttiva Macchine 2006/42/CE

I motoriduttori, motoriviiangolari, motorivariatori e i motori elettrici GSM non sono macchine ma organi da installare o assemblare nelle macchine.

Marchio CE, dichiarazione del fabbricante e dichiarazione di conformità.

I motoriduttori, motorivariatori e i motori elettrici hanno il marchio CE.

Questo marchio indica la loro conformità alla direttiva Bassa Tensione e alla direttiva Compatibilità Elettromagnetica.

Su richiesta, GSM può fornire la dichiarazione di conformità dei prodotti e la dichiarazione del fabbricante secondo la direttiva macchine.

ISO 9001

I prodotti GSM sono realizzati all'interno di un sistema di qualità conforme allo standard ISO 9001. A tal fine su richiesta è possibile rilasciare copia del certificato.

1.6.5 Normative riferimento Progettazione e Fabbricazione**Ingranaggi**

Gli ingranaggi cilindrici a dentatura elicoidale, sono rettificati sul profilo ad evolvente dopo cementazione, tempra e rinvenimento finale.

Gli ingranaggi conici a dentatura Gleason sono rodati, (o rettificati a seconda della grandezza del riduttore), dopo cementazione tempra e rinvenimento finale.

Cuscinetti

Tutti i cuscinetti sono del tipo a rulli conici o a rulli orientabili, di elevata qualità e dimensionati per garantire una lunga durata se lubrificati con il tipo di lubrificante previsto a catalogo.

Carcassa

La carcassa è ottenuta per fusione in GJL 250 UNI EN 1561 o in ghisa a grafite sferoidale UNI EN 1563 2004 fino alla grandezza 824-826.

I particolari accorgimenti adottati nel disegno della struttura permettono di ottenere un' elevata rigidità.

1.6 Standards applied**1.6.4 UE Directives-CE mark-ISO 9001****Directive 2014/35/UE Low Voltage GSM**

geared motors, right angle drives with motor, motorvariators and electric motors meet the specification of the low voltage directive.

2014/30/UE Electromagnetic Compatibility

GSM geared motors, right angle drives with motor, motorvariators and electric motors correspond to the specifications of the EMC directive.

Machinery Directive 2006/42/CE

GSM geared motors, right angle drives with motor, motorvariators and electric motors are not standalone machines, they are exclusively for installation into a machine or for assembly on a machine.

CE Mark, Conformity Declarations and Manufacturer's Declaration.

GSM geared motors, right angle drives with motor, motorvariators and electric motors carry the CE Mark.

It indicates conformity to the low voltage directive and to electromagnetic compatibility directive.

On request GSM supplies both the conformity declarations and the manufacturer's declaration according to the machine directive.

ISO 9001

GSM products have been designed and manufactured according to ISO 9001 quality system standard.

On request a copy of the certification can be

1.6.5 Standards applied**Gearing**

Helical gear sets are first case hardened, hardened and tempered and finally their involute profile is ground.

Gleason bevel gear sets are first case hardened, hardened and tempered and finally broken in (or ground, depending on gear unit size).

Bearings

All bearings are high quality taper or self-aligning roller bearings suitably sized to ensure long service life provided the approved lubricants indicated in this catalogue are used.

Casing

Casings up to size 824-826 are cast from GJL 250 UNI EN 1561 cast iron or from Spheroidal cast iron.

Casing design incorporates special arrangements to provide superior rigidity.

1.6 Angewendete Normen**1.6.4 UE-Richtlinien - CE-Zeichen - ISO9001****Niederspannungsrichtlinie. 2014/35/UE**

Die Getriebemotoren, Winkelgetriebe, Verstellgetriebe und Elektromotoren der GSM entsprechen den Vorschriften der Niederspannungsrichtlinie.

2014/30/UE Elektromagnetische Verträglichkeit

Die Getriebemotoren, Winkelgetriebe, Verstellgetriebe und Elektromotoren der GSM entsprechen den Vorschriften der Richtlinie zur Elektromagnetischen Verträglichkeit.

Maschinenrichtlinie 2006/42/CE

Die Getriebemotoren, Winkelgetriebe, Verstellgetriebe und Elektromotoren der GSM sind keine Maschinen sondern Organe, die in Maschinen eingebaut oder an diesen montiert werden.

CE-Zeichen, Hersteller- und Konformitätserklärung

Die Getriebemotoren, Verstellgetriebe und Elektromotoren tragen das CE-Zeichen.

Dieses Zeichen weist auf ihre Konformität mit der Niederspannungsrichtlinie und der Richtlinie zur Elektromagnetischen

Verträglichkeit hin.

Auf Anfrage kann die GSM die Konformitätserklärung und die Herstellererklärung gemäß Maschinenrichtlinie zu den Produkten liefern.

ISO 9001

Die GSM-Produkte werden in einem Qualitätssystem gemäß dem Standard ISO 9001 realisiert. Auf Anfrage kann daher eine Kopie der Zertifizierung geliefert werden.

1.6.5 Bezugsnormen Entwicklung und Produktion**Zahnräder**

Das Evolventenprofil der Stirnrädergetriebe mit Schrägverzahnung wird nach dem Einsatzhärten, dem Abschrecken und dem Anlassen entsprechend geschliffen.

Die Kegelnzahnäder mit Gleason-Verzahnung sind bereits eingelaufen (oder in Abhängigkeit der Getriebegröße geschliffen), dies erfolgt nach dem Einsatzhärten, Abschrecken

Lager

Bei allen Lagern handelt es sich um hochqualitative Kegelrollenlager mit orientierungsfähigen Rollen und in Maßen, die so ausgelegt sind, dass sie bei Einsatz der gemäß Katalogangaben vorgesehenen Schmiermittel eine lange Lebensdauer garantieren.

Gehäuse

Die Gehäuse der Getriebe bis Baugröße 824-826 werden im Gussverfahren aus GJL 250 UNI EN 1561 oder Sphäroguss UNI EN 1563 2004 gewonnen.

Die besonderen beim Entwurf der Struktur berücksichtigten Vorkehrungen verleihen ihr eine besondere Steifheit.



1.6 Normative applicate**Alberi**

Gli alberi lenti sono verificati a flesso-torsione con elevato coefficiente di sicurezza. Le estremità d'albero cilindriche sono secondo UNI 6397-68, DIN 748, NF E 22.051, BS 4506-70, ISO/R 775-69, escluso corrispondenza R-S, con foro filettato in testa secondo DIN 1414. Linguetta secondo UNI 6604-69, DIN 6885 B1, 1-68, NF E 27.656 22.175, BS 4235.1-72, ISO/R 773-69 escluso corrispondenza I.

Tutti i prodotti della GSM sono progettati nel rispetto delle seguenti normative:

Calcolo degli ingranaggi

In corrispondenza alla "CTI CODE TOWER-STD-111 (2009)" i dati espressi in questo catalogo, senza alcuna necessità di ulteriori fattori applicativi, soddisfano la condizione progettuale di durata di 100.000 ore di funzionamento secondo le seguenti normative abbinata ai corrispettivi fattori di applicazione - FS; - FS=3.6 - ISO 10300:2001 METODO B e ISO 6336:2006 METODO B; e/o - FS=3.8 - DIN 3991:1988 e DIN 3990:1987 METODO B; e/o -FS=2 - AGMA 2003-C10 e AGMA 2001-C95

Calcolo dei cuscinetti

In corrispondenza alla "CTI CODE TOWER-STD-111 (2009)" i dati espressi in questo catalogo soddisfano le seguenti condizioni progettuali di durata: Asse di uscita: $L_{nm}=100.000$ ore minime di funzionamento
Asse entrata ed intermedio: $L_{nm}=50.000$ ore minime di funzionamento

L_{nm} = ISO 281 - Calcolo della durata a fatica dei cuscinetti volventi.

Alberi

DIN 743
Calcolo della durata a fatica degli alberi

Materiali

EN 10084
Acciaio da cementazione per ingranaggi e viti senza fine.

EN 10083
Acciaio da bonifica per alberi.

UNI EN 1706
Alluminio e leghe di Alluminio

UNI EN 1561
Fusioni in ghisa grigia.

UNI EN 1563 2004
Getti di ghisa a grafite sferoidale

UNI 3097
Acciaio per cuscinetti per piste rotolamento.

1.6 Standards applied**Shafts**

Output shafts are calculations incorporate a high safety factor and are validated by bending and torsional stress analyses. Cylindrical shaft ends are in accordance with UNI 6397-68, DIN 748, NF E 22.051, BS 4506-70, ISO/R 775-69, excluding section R-S, with centre tapped hole at shaft end to DIN 1414. Keys are in accordance with UNI 6604-69, DIN 6885 B1, 1-68, NF E27.656 22.175, BS 4235.1-72, ISO/R 773-69 excluding section I.

All GSM products are designed following these standards:

Calculation of gear

According to the "CTI CODE TOWER-STD-111 (2009)" the data shown in this catalog, without any need of further application factors, satisfy the design condition of operating lifetime of 100,000 hours according to following standards matched to the corresponding factors of application - FS; - FS=3.6 - ISO 10300:2001 METODO B e ISO 6336:2006 METODO B; e/o - FS=3.8 - DIN 3991:1988 e DIN 3990:1987 METODO B; e/o -FS=2 - AGMA 2003-C10 e AGMA 2001-C95

Calculation of bearings

According to the "CTI CODE TOWER-STD-111 (2009)" the data shown in this catalog meet the following design conditions of lifetime:

*Output axis: $L_{nm}= 100.000$ hours min. of operation
Input and intermediate axis: $L_{nm}= 50.000$ hours min. of operation*

L_{nm} = ISO 281 - ISO 281 - Rolling bearings
Dynamic load ratings and rating life

Shafts

DIN743
Shafts — Dynamic load ratings and rating life

Materials

EN 10084
Case hardening steels for gears and worms

EN 10083
Quenched and Tempered Steels for shafts

UNI EN 1706
Aluminium alloy

UNI EN 1561
Grey iron casting

UNI EN 1563 2004
Spheroidal cast iron

UNI 3097
Ball and roller bearing steel

1.6 Angewendete Normen**Wellen**

Die Abtriebswellen werden unter Berücksichtigung eines hohen Sicherheitskoeffizienten auf Biegung-Windung getestet. Die Enden der zylindrischen Wellen entsprechen den Normen UNI 6397-68, DIN 748, NF E 22.051, BS 4506-70, ISO/R 775-69, ausgenommen Zuordnung R-S, mit Gewindebohrung in der Wellenspitze DIN 1414. Die Federkeile entsprechen UNI 6604-69, DIN 6885 B1, 1-68, NF E 27.656 22.175, BS 4235.1-72, ISO/R 773-69, ausgenommen Zuordnung I.

Alle Produkte der GSM werden unter Einhaltung folgender Normen entwickelt:

Berechnung der Zahnräder und Lager

Gemäß der "CTI CODE TOWER-STD-111 (2009)" sind die Angaben in diesem Katalog, ohne Notwendigkeit weiterer Anwendungsfaktoren, erfüllend für die Bedingung der Lebensdauer von 100.000 Betriebsstunden und nach folgenden Normen zu den entsprechenden Anwendungsfaktoren abgestimmt - FS; - FS=3.6 - ISO 10300:2001 METODO B e ISO 6336:2006 METODO B; e/o - FS=3.8 - DIN 3991:1988 e DIN 3990:1987 METODO B; e/o -FS=2 - AGMA 2003-C10 e AGMA 2001-C95

Berechnung der und Lager

In Übereinstimmung mit dem "CTI CODE TOWER-STD-111 (2009)" erfüllen die Angaben in diesem Katalog die folgenden Lebensdauerbedingungen
Abtriebswelle: $L_{nm} = 100.000$ Stunden minimaler Gebrauch
Antriebswelle: $L_{nm} = 50.000$ Stunden minimaler Gebrauch

L_{nm} = ISO 281 - Berechnung der Belastungsdauer der Wälzlager.

Wellen

DIN743
Berechnung der Belastungsdauer der Wellen.

Material

EN 10084
Einsatzstahl für Zahnräder und Schnecken.

EN 10083
Vergütungsstahl für Wellen.

UNI EN 1706
Aluminium und Aluminiumlegierungen

UNI EN 1561
Grauguss-Legierungen

UNI EN 1563 2004
Sphäroguss

UNI 3097
Stahl für Lagergleitbahnen



1.7 Designazione

1.7 Designation

1.7 Bezeichnung

CODE:
Example of Order

- - RX P 2 - 802 AN

BASIC_CODE_GEARBOX

Gearbox coding parameters - BASIC

CODE-R

Certification	Marking Gearbox	Maschine	Centerline Orientation	N° of reductions	Version reinforced	Size	Shaft arrangement
01 CERR	02 MARR	03 M	04 CO	05 NOR	06 RV	07 SIZE	08 SA

WEB:
Reference Designation

ATEX	Gb-4 Gb-5 Db-4 Db-5 Gc-4 Gc-5 Dc-4 Dc-5	<div style="border: 1px solid gray; padding: 5px; text-align: center; font-weight: bold; font-size: 1.2em;">RX</div>	<div style="border: 1px solid gray; padding: 5px; text-align: center; font-weight: bold; font-size: 1.2em;">P</div>	<div style="border: 1px solid gray; padding: 5px; text-align: center; font-weight: bold; font-size: 1.2em;">2</div>	<div style="border: 1px solid gray; padding: 5px; text-align: center; font-weight: bold; font-size: 1.2em;">-</div>	<div style="border: 1px solid gray; padding: 5px;"> <p style="margin: 0;">802</p> <p style="margin: 0;">804</p> <p style="margin: 0;">806</p> <p style="margin: 0;">808</p> <p style="margin: 0;">810</p> <p style="margin: 0;">812</p> <p style="margin: 0;">814</p> <p style="margin: 0;">816</p> <p style="margin: 0;">818</p> <p style="margin: 0;">820</p> </div>	<div style="border: 1px solid gray; padding: 5px; text-align: center; font-weight: bold; font-size: 1.2em;">AN</div> <div style="border: 1px solid gray; padding: 5px; text-align: center; font-weight: bold; font-size: 1.2em;">AB</div>
------	--	--	---	---	---	--	--

CF

VEM

OPT2

TYP3

TYP4

b-Gb-4
b-Gb-5
b-Gc-4
b-Gc-5

b-Db-4-x
b-Db-5-x
b-Dc-4-x
b-Dc-5-x

1.7 Designazione

1.7 Designation

1.7 Bezeichnung

16.0 - - - **PAM** **132** **G** - - - **CR** - **M5**

BASIC_CODE_GEARBOX

Gearbox coding parameters - BASIC

CODE-R

Reduction ratio	Input Version Left	Input Shaft Left	IEC type and Input Shaft Left	Input Version Right	Input Shaft Right	IEC type and Input Shaft Right	Cooling fans	Backstop	Housing material	Output flange	Output Shaft	Mounting position output Flange	Mounting positions
09 IR	10 IVL	11 TSL	12 IECTL	13 IVR	14 ISR	15 IECTR	16 CF	17 BSTOP	18 CM	19 OF	20 OS	21 MPOF	22 MP

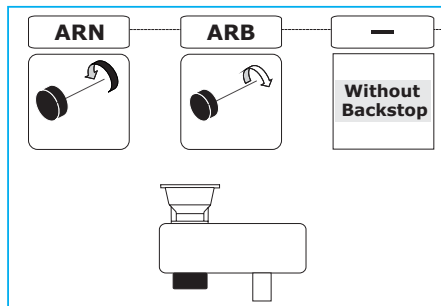
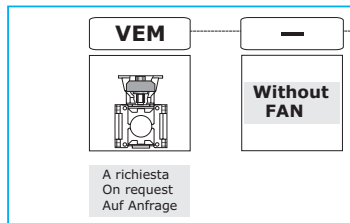
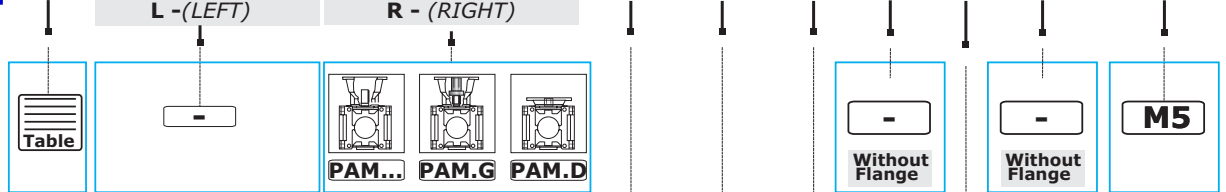

-	Senza Antiretro Without Backstop Ohne Rücklaufsperr
ARB	Rotazione libera freccia bianca (B) Free rotation - white arrow (B) Freie Drehung - weißer Pfeil (B)
ARN	Rotazione libera freccia nera (N) Free rotation - black arrow (N) Freie Drehung - schwarzer Pfeil (N)

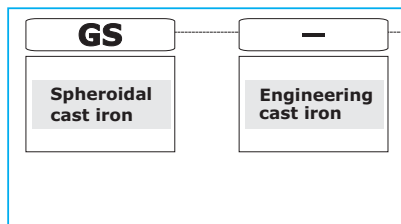

- (G)	Ghisa meccanica Engineering cast iron Maschinenguss
GS	Ghisa sferoidale Spheroidal cast iron Sphäroguss



1.8 Lubrificazione

Gli oli consigliati per i riduttori della serie RX per applicazione CR sono di tipo sintetico a base di Poli-Alfa-Oleofine (PAO); ogni costruttore di olio realizza però il proprio prodotto con indici di viscosità ed additivazioni differenti.

Per facilitare la scelta del lubrificante, GSM ha realizzato una tabella riassuntiva che, a seconda delle condizioni applicative del riduttore, indica gli oli più consoni di diversi brand presenti sul mercato.

1.8 Lubrication



The best suitable oil for RX gearbox series for CR application are synthetic and containing poly-Alfa-Olefin (PAO). As a matter of fact each oil producer creates his own product with different viscosity indexes and additives.







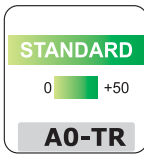
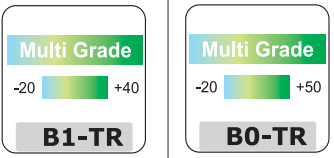





For this reason GSM has created a list with all brands of suitable lubricants which are available on the market, also taking into consideration the many different conditions of the gearbox applications.

1.8 Schmierung

Die empfohlenen Öle für Getriebe der RX Serie für die CR-Anwendungen basieren auf synthetischen Poly-Alpha-Olefinen (PAO). Allerdings hat jeder Ölhersteller eigene Angaben zu Viskosität und Additiven.

Um die Wahl des Schmiermittels zu erleichtern, hat GSM eine Übersichtstabelle realisiert, die abhängig von den Einsatzbedingungen der Getriebe sind. Angegeben werden die geeignetsten Öle verschiedener Marken auf dem Markt.

Viscosity ISO VG at 40° (cSt)		ZONE RANGE - OPTZ Ambient Temperature - Ta - [°C]		ZONE STANDARD		ZONE MULTIGRADE	
							
RANGE	1750 < n ₁ ≤ 1000			220			
Input speed - n ₁ [min .-]	1000 < n ₁ ≤ 500			220		100	220
HEATERS	without applying any heaters						

Viscosity - ISO VG at 40° (cSt) - CLP -HC TYPE OILS - (PAO) Poly-Alpha-Olefin synthetic				
	68	100	150	220
	—	—	Degol PAS 150	Degol PAS 220
	—	—	Meropa Synthetic EP 150	Meropa Synthetic EP 220
		Optigear Synthetic X 100	Optigear Synthetic X 150	Optigear Synthetic X 220
	Optigear Synthetic PD 68		Optigear Synthetic PD 150	Optigear Synthetic PD 220
	—	—	Meropa Synthetic EP 150	Meropa Synthetic EP 220
	—	—	Agip Blasia FSX 150	Agip Blasia FSX 220
	Renolin Unisyn CLP 68	Renolin Unisyn CLP 100	Renolin Unisyn CLP 150	Renolin Unisyn CLP 220
		Renolin Unisyn XT 100	Renolin Unisyn XT 150	Renolin Unisyn XT 220
			Klubersynth EG4-150	Klubersynth EG4-220
	Klübersynth GEM 4 - 68 N	Klübersynth GEM 4 - 100 N	Klübersynth GEM 4 - 150 N	Klübersynth GEM 4 - 220 N
	—	—	Mobilgear SHC XMP 150	Mobilgear SHC XMP 220
	—	—	Gear Syn PAO 150	Gear Syn PAO 220
	—	—	OMALA S4 GX 150	OMALA S4 GX 220
	—	—	Meropa Synthetic EP 150	Meropa Synthetic EP 220
	—	—	Carter SH 150	Carter SH 220

1.8 Lubrificazione

1.8 Lubrication

1.8 Schmierung

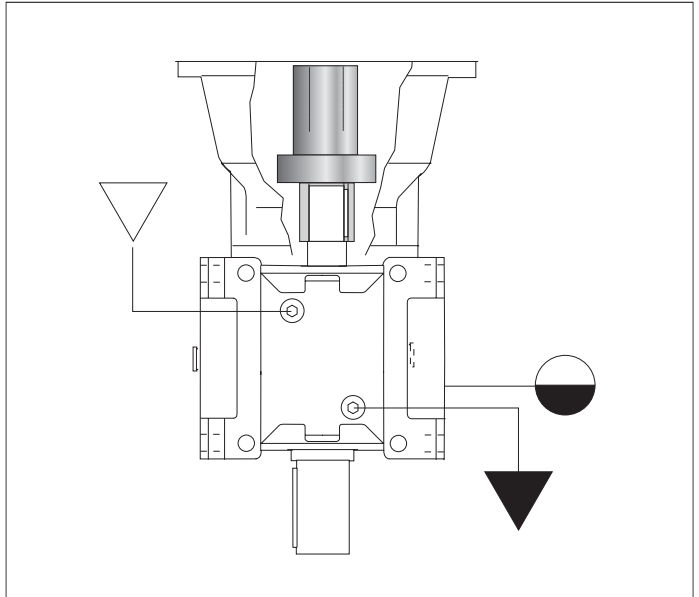
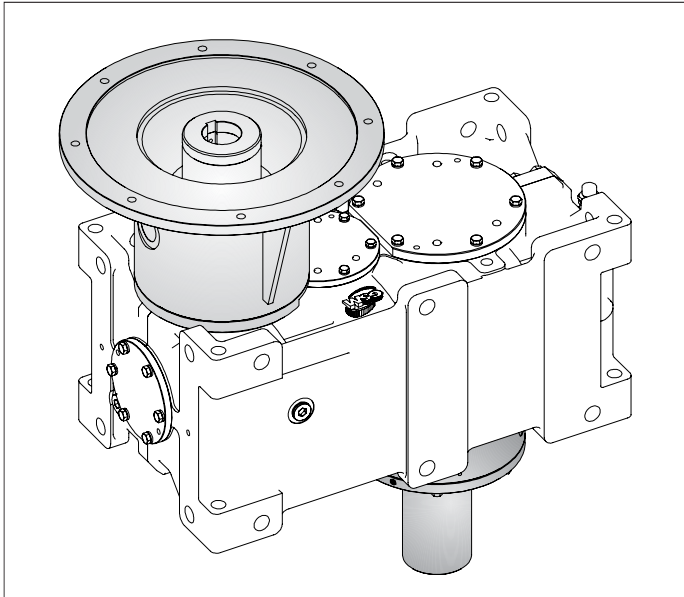

- ▽ Carico / Filler plug/
- ▼ Scarico / Drain plug / Ablassschraube
- Livello / Level plug / Schauglas

M5

	Quantità di lubrificante / Lubricant Quantity / Schmiermittelmenge (l)									
	802	804	806	808	810	812	814	816	818	820
RXP2-CR	2.1	2.9	4.2	5.9	8.1	11.3	15.8	22.5	31.5	44.6

Le quantità di olio sono approssimative; per una corretta lubrificazione occorre fare riferimento al livello segnato sul riduttore.
ATTENZIONE
 Eventuali forniture con predisposizioni tappi diverse da quella indicata in tabella, dovranno essere concordate

Oil quantities listed in the table are approximate; to ensure correct lubrication, please refer to the level mark on the gear unit.
WARNING
Any plug arrangements other than that indicated in the table must be agreed upon.

Bei den Ölmengenangaben handelt es sich um approximative Werte; für den Erhalt einer korrekten Schmierung muss Bezug auf den am Getriebe gekennzeichneten Füllstand genommen werden.
ACHTUNG
 Eventuelle Lieferungen mit einer von den Tabellenangaben abweichenden Anordnung der Stopfen müssen zuvor abgestimmt werden.



1.9 Prestazioni riduttori

1.9 Gear unit ratings

1.9 Leistungen der Getriebe

RXP2 802

Calculation of gear - Service Factor:
3.6-ISO; 3.8-DIN; 2.0 - AGMA

Calculation of bearings - hours min - ISO 281
Output axis: 100.000 - Others axis: 50.000



116

ir	J1 kgm ²	n ₁ = 1750 min ⁻¹					n ₁ = 1450 min ⁻¹					n ₁ = 1160 min ⁻¹					n ₁ = 970 min ⁻¹				
		n ₂ min ⁻¹	P kW	T _N Nm	Fr ₂ kN	Fa ₂ kN	n ₂ min ⁻¹	P kW	T _N Nm	Fr ₂ kN	Fa ₂ kN	n ₂ min ⁻¹	P kW	T _N Nm	Fr ₂ kN	Fa ₂ kN	n ₂ min ⁻¹	P kW	T _N Nm	Fr ₂ kN	Fa ₂ kN
4,60	0,0114	380	63	1529		8,3	315	55	1600		8,3	252	41,8	1520		8,4	211	34,3	1492		8,6
5,12	0,0100	342	58	1542	A richiesta / On request / Auf Anfrage	8,3	283	48	1544		8,3	227	37,5	1517		8,5	189	30,9	1495	A richiesta / On request / Auf Anfrage	8,7
5,70	0,0087	307	55	1643		8,3	254	43	1543		8,3	203	33,6	1514		8,6	170	27,7	1493		8,9
6,37	0,0076	275	47	1568		8,3	228	38	1542		8,4	182	30,1	1515		8,7	152	24,9	1498		9,5
7,13	0,0067	245	42	1569		8,3	203	34	1542		8,5	163	27,1	1527		8,9	136	22,3	1503		9,9
8,01	0,0058	218	37	1562		8,5	181	30	1540		8,7	145	23,9	1514		9,7	121	20,0	1515		10,3
9,05	0,0051	193	33	1556		8,6	160	27	1540		9,2	128	22,0	1574		10,1	107	18,8	1609		10,9
10,3	0,0043	170	30	1617		9,0	141	24	1542		9,7	113	19,6	1594		10,5	94	17,3	1682		11,1
11,8	0,0037	148	25	1550		9,5	123	22	1639		10,3	98	18,5	1723		11,0	82	15,6	1738		11,6
12,7	0,0031	138	23	1545		9,9	115	20	1593		10,5	92	17,0	1701		11,3	77	15,0	1795		11,9
13,6	0,0026	128	22	1571		10,2	106	19	1621		10,8	85	16,2	1746		11,5	71	15,0	1933		12,2
16,0	0,0023	110	19	1624		10,6	91	17	1717		11,3	73	15,0	1894		12,0	61	12,5	1887		12,8
17,4	0,0020	101	19	1686		11,0	83	16	1771		11,6	67	13,6	1870		12,4	56	11,6	1907		13,3
19,0	0,0018	92	19	1845		11,3	76	15	1806		12,0	61	12,6	1896		12,8	51	11,0	1979		13,8
21,0	0,0015	84	16	1789		11,6	69	15	1987		12,3	55	11,5	1904		13,4	46	9,9	1961		14,2
23,2	0,0014	75	15	1849		12,0	62	13	1923		12,7	50	11,0	2018		13,8	42	9,2	2019		14,7

Potenze termiche / Thermal power / Thermische Grenzleistung PtN [kW]

(senza raffreddamento / Without cooling / ohne Kühlung)

30

RXP2 804

Calculation of gear - Service Factor:
3.6-ISO; 3.8-DIN; 2.0 - AGMA

Calculation of bearings - hours min - ISO 281
Output axis: 100.000 - Others axis: 50.000



155

ir	J1 kgm ²	n ₁ = 1750 min ⁻¹					n ₁ = 1450 min ⁻¹					n ₁ = 1160 min ⁻¹					n ₁ = 970 min ⁻¹				
		n ₂ min ⁻¹	P kW	T _N Nm	Fr ₂ kN	Fa ₂ kN	n ₂ min ⁻¹	P kW	T _N Nm	Fr ₂ kN	Fa ₂ kN	n ₂ min ⁻¹	P kW	T _N Nm	Fr ₂ kN	Fa ₂ kN	n ₂ min ⁻¹	P kW	T _N Nm	Fr ₂ kN	Fa ₂ kN
4,63	0,0200	378	99,0	2401		10,6	313	82,0	2400		10,3	251	66,8	2444		10,1	210	55,0	2406		10,3
5,14	0,0176	340	90,0	2425	A richiesta / On request / Auf Anfrage	10,4	282	75,1	2442		10,1	226	60,0	2439		10,2	189	49,4	2401	A richiesta / On request / Auf Anfrage	10,5
5,72	0,0154	306	80,6	2417		10,2	253	67,5	2443		10,1	203	55,0	2488		10,3	169	45,0	2434		10,5
6,38	0,0135	274	75,0	2508		10,0	227	60,7	2450		10,1	182	48,1	2427		10,5	152	39,7	2396		10,8
7,14	0,0118	245	66,0	2470		10,1	203	55,0	2484		10,2	162	45,0	2540		10,6	136	37,0	2498		11,4
8,02	0,0104	218	59,2	2488		10,2	181	48,6	2465		10,4	145	38,3	2429		11,1	121	31,6	2396		12,0
9,06	0,0090	193	55,0	2609		10,3	160	45,0	2577		10,6	128	33,9	2426		11,7	107	30,0	2568		12,5
10,3	0,0077	170	46,0	2479		10,5	141	37,5	2439		11,2	113	30,0	2439		12,3	94	25,7	2498		13,0
11,0	0,0066	159	45,0	2592		10,5	132	37,0	2572		11,5	106	27,9	2424		12,7	88	24,6	2556		13,4
12,6	0,0055	138	37,0	2451		11,3	115	30,4	2430		12,3	92	25,3	2528		13,3	77	22,2	2653		14,0
13,6	0,0047	129	34,3	2446		11,7	107	28,2	2427		12,5	85	23,9	2571		13,6	71	22,0	2831		14,3
15,9	0,0040	110	30,0	2506		12,3	91	23,4	2359		13,3	73	22,0	2772		14,2	61	18,5	2788		15,0
17,4	0,0036	101	27,3	2482		12,9	84	23,8	2612		13,7	67	20,0	2744		14,7	56	17,0	2789		15,5
19,0	0,0032	92	25,7	2557		13,2	76	22,5	2701		14,0	61	18,5	2776		15,2	51	15,7	2818		16,0
20,9	0,0027	84	24,0	2627		13,6	69	22,0	2906		14,5	56	17,1	2824		15,7	46	15,0	2962		16,5
23,1	0,0024	76	22,5	2728		14,1	63	19,3	2824		15,0	50	15,5	2835		16,3	42	13,0	2844		17,0

Potenze termiche / Thermal power / Thermische Grenzleistung PtN [kW]

(senza raffreddamento / Without cooling / ohne Kühlung)

39

1.9 Prestazioni riduttori

1.9 Gear unit ratings

1.9 Leistungen der Getriebe

RXP2 806

Calculation of gear - Service Factor:
3.6-ISO; 3.8-DIN; 2.0 - AGMA

Calculation of bearings - hours min - ISO 281
Output axis: 100.000 - Others axis: 50.000



220

ir	J1 kgm ²	n ₁ = 1750 min ⁻¹					n ₁ = 1450 min ⁻¹					n ₁ = 1160 min ⁻¹					n ₁ = 970 min ⁻¹				
		n ₂ min ⁻¹	P kW	T _N Nm	Fr ₂ kN	Fa ₂ kN	n ₂ min ⁻¹	P kW	T _N Nm	Fr ₂ kN	Fa ₂ kN	n ₂ min ⁻¹	P kW	T _N Nm	Fr ₂ kN	Fa ₂ kN	n ₂ min ⁻¹	P kW	T _N Nm	Fr ₂ kN	Fa ₂ kN
4,46	0,0053	392	135,0	3154	A richiesta / On request / Auf Anfrage	5,8	325	113,1	3189	A richiesta / On request / Auf Anfrage	5,2	260	92,3	3253	A richiesta / On request / Auf Anfrage	4,5	218	77,2	3254	A richiesta / On request / Auf Anfrage	4,5
4,94	0,0049	354	123,0	3182		5,5	294	104,0	3248		4,7	235	84,4	3294		4,5	196	69,4	3240		4,7
5,48	0,0274	320	111,8	3207		5,0	265	94,1	3258		4,5	212	75,9	3285		4,5	177	62,4	3230		4,9
6,08	0,0240	288	101,7	3241		4,7	238	90,0	3461		4,5	191	68,0	3269		4,6	159	56,0	3220		5,1
7,16	0,0210	245	90,0	3374		4,5	203	75,0	3393		4,5	162	57,5	3252		5,0	136	47,4	3206		5,5
8,49	0,0184	206	75,5	3356		4,5	171	61,5	3300		4,7	137	48,3	3239		5,4	114	40,0	3208		5,8
9,00	0,0160	194	71,1	3353		4,5	161	57,7	3284		4,9	129	45,6	3245		5,5	108	37,7	3208		6,8
10,2	0,0137	172	62,5	3333		4,6	142	51,0	3282		5,2	114	40,2	3234		6,5	95	33,7	3242		7,5
11,6	0,0116	151	55,0	3339		5,0	125	45,0	3297		5,5	100	37,0	3389		7,2	84	30,9	3385		7,8
12,4	0,0097	141	51,0	3315		5,2	117	41,8	3279		6,2	94	33,6	3294		7,5	78	30,0	3518		8,0
14,3	0,0083	122	45,0	3378		5,8	101	37,0	3352		7,3	81	30,6	3465		7,8	68	26,9	3643		8,3
15,5	0,0072	113	40,9	3314		6,3	94	34,2	3345		7,4	75	30,0	3668		8,0	63	25,6	3743		8,5
18,2	0,0063	96	37,0	3536		7,3	79	30,5	3517		7,9	64	26,1	3763		8,4	53	22,3	3844		9,4
19,9	0,0056	88	33,2	3469		7,5	73	30,0	3783		8,0	58	24,4	3846		8,7	49	20,5	3864		10,0
21,9	0,0048	80	31,2	3585		7,8	66	27,2	3772		8,2	53	22,2	3849		9,5	44	18,9	3918		10,7
24,3	0,0043	72	30,0	3817		8,0	60	25,2	3870		8,6	48	20,7	3973		10,0	40	17,4	3994		11,4

Potenze termiche / Thermal power / Thermische Grenzleistung PtN [kW]

(senza raffreddamento / Without cooling / ohne Kühlung)

51

RXP2 808

Calculation of gear - Service Factor:
3.6-ISO; 3.8-DIN; 2.0 - AGMA

Calculation of bearings - hours min - ISO 281
Output axis: 100.000 - Others axis: 50.000



300

ir	J1 kgm ²	n ₁ = 1750 min ⁻¹					n ₁ = 1450 min ⁻¹					n ₁ = 1160 min ⁻¹					n ₁ = 970 min ⁻¹				
		n ₂ min ⁻¹	P kW	T _N Nm	Fr ₂ kN	Fa ₂ kN	n ₂ min ⁻¹	P kW	T _N Nm	Fr ₂ kN	Fa ₂ kN	n ₂ min ⁻¹	P kW	T _N Nm	Fr ₂ kN	Fa ₂ kN	n ₂ min ⁻¹	P kW	T _N Nm	Fr ₂ kN	Fa ₂ kN
4,44	0,0092	394	225	5239	A richiesta / On request / Auf Anfrage	5,0	326	182	5120	A richiesta / On request / Auf Anfrage	4,2	261	148	5185	A richiesta / On request / Auf Anfrage	3,2	218	123	5184	A richiesta / On request / Auf Anfrage	3,0
4,94	0,0086	354	204	5281		3,8	293	169	5271		3,2	235	133	5186		3,0	196	110	5137		3,5
5,50	0,0488	318	182	5238		3,8	264	160	5564		3,0	211	117	5095		3,5	176	97	5016		4,0
6,13	0,0427	285	162	5212		3,5	236	132	5134		3,3	189	110	5332		3,6	158	90	5217		4,3
7,26	0,0374	241	135	5115		3,5	200	110	5049		3,9	160	90	5164		4,6	134	75	5146		5,0
8,16	0,0328	214	118	5036		3,8	178	96	4953		4,5	142	76	4876		5,2	119	63	4836		5,8
9,22	0,0284	190	103	4964		4,3	157	84	4895		5,0	126	66	4830		5,6	105	55	4792		6,2
9,82	0,0243	178	96	4938		4,5	148	79	4873		5,2	118	62	4819		6,0	99	55	5104		7,0
11,2	0,0207	156	83	4882		5,1	129	68	4837		5,6	104	55	4869		7,0	87	48	5060		7,5
12,0	0,0173	146	77	4860		5,5	121	64	4818		6,0	97	55	5216		7,0	81	46	5161		7,7
13,9	0,0148	126	66	4822		6,0	104	55	4828		7,0	84	47	5113		7,7	70	41	5380		8,2
16,3	0,0128	108	56	4806		7,0	89	49	5029		7,5	71	42	5361		8,2	60	37	5689		8,7
17,7	0,0112	99	55	5104		7,4	82	46	5175		7,9	65	39	5488		8,5	55	37	6195		8,5
19,4	0,0100	90	50	5047		7,7	75	45	5515		8,0	60	37	5669		8,9	50	33	5954		9,3
21,3	0,0086	82	47	5197		8,0	68	41	5490		8,3	54	37	6238		8,5	45	31	6150		9,7
23,6	0,0077	74	45	5572		8,2	61	38	5679		8,6	49	30	5604		9,0	41	30	6702		9,7

Potenze termiche / Thermal power / Thermische Grenzleistung PtN [kW]

(senza raffreddamento / Without cooling / ohne Kühlung)

66

1.9 Prestazioni riduttori

1.9 Gear unit ratings

1.9 Leistungen der Getriebe

RXP2 810

Calculation of gear - Service Factor:
3.6-ISO; 3.8-DIN; 2.0 - AGMA

Calculation of bearings - hours min - ISO 281
Output axis: 100.000 - Others axis: 50.000



440

ir	J1 kgm ²	n ₁ = 1750 min ⁻¹					n ₁ = 1450 min ⁻¹					n ₁ = 1160 min ⁻¹					n ₁ = 970 min ⁻¹				
		n ₂ min ⁻¹	P kW	T _N Nm	Fr ₂ kN	Fa ₂ kN	n ₂ min ⁻¹	P kW	T _N Nm	Fr ₂ kN	Fa ₂ kN	n ₂ min ⁻¹	P kW	T _N Nm	Fr ₂ kN	Fa ₂ kN	n ₂ min ⁻¹	P kW	T _N Nm	Fr ₂ kN	Fa ₂ kN
4,52	0,0160	387	317	7513		22,2	321	265	7580		21,2	256	215	7687		20,2	214	181	7730		19,6
5,03	0,0151	348	288	7596		21,6	288	250	7950		20,7	231	200	7950		19,9	193	164	7796		19,8
5,60	0,0867	313	260	7625		21,1	259	225	7964		20,3	207	176	7787		19,6	173	148	7852		19,9
6,24	0,0760	280	235	7673		20,6	232	200	7894		19,8	186	160	7894		19,8	155	133	7848		20,2
6,98	0,0665	251	212	7741		20,1	208	177	7807		19,6	166	142	7839		20,0	139	118	7797		20,5
8,31	0,0583	211	180	7815		19,6	175	150	7893		19,8	140	119	7838		20,5	117	99	7748		21,0
9,38	0,0506	187	160	7884		19,8	155	134	7919		20,2	124	110	8157		20,8	103	90	7981		21,8
9,99	0,0433	175	151	7906		20,0	145	125	7898		20,4	116	99	7780		21,1	97	82	7726		22,5
11,4	0,0368	154	133	7967		20,1	127	110	7929		20,8	102	90	8109		22,0	85	75	8081		23,8
12,2	0,0307	143	124	7941		20,3	119	101	7831		21,0	95	80	7752		22,8	79	70	8035		24,6
14,1	0,0263	124	110	8143		20,8	103	90	8041		22,0	82	75	8376		23,9	69	62	8267		25,5
16,6	0,0227	106	91	7850		21,6	88	76	7904		23,5	70	63	8296		25,3	59	55	8607		27,2
18,0	0,0196	97	83	7878		22,5	80	75	8550		24,0	64	58	8308		26,3	54	49	8333		28,3
19,7	0,0177	89	77	7918		23,4	73	67	8333		25,0	59	55	8577		27,2	49	45	8448		29,2
21,7	0,0153	81	75	8532		24,0	67	61	8416		25,5	53	49	8444		28,2	45	42	8538		30,4
24,1	0,0136	73	67	8407		25,0	60	56	8473		27,0	48	45	8557		29,5	40	38	8595		31,6

Potenze termiche / Thermal power / Thermische Grenzleistung PtN [kW]
(senza raffreddamento / Without cooling / ohne Kühlung)

82

RXP2 812

Calculation of gear - Service Factor:
3.6-ISO; 3.8-DIN; 2.0 - AGMA

Calculation of bearings - hours min - ISO 281
Output axis: 100.000 - Others axis: 50.000



580

ir	J1 kgm ²	n ₁ = 1750 min ⁻¹					n ₁ = 1450 min ⁻¹					n ₁ = 1160 min ⁻¹					n ₁ = 970 min ⁻¹				
		n ₂ min ⁻¹	P kW	T _N Nm	Fr ₂ kN	Fa ₂ kN	n ₂ min ⁻¹	P kW	T _N Nm	Fr ₂ kN	Fa ₂ kN	n ₂ min ⁻¹	P kW	T _N Nm	Fr ₂ kN	Fa ₂ kN	n ₂ min ⁻¹	P kW	T _N Nm	Fr ₂ kN	Fa ₂ kN
4,53	0,0846	386	427	10140		23,3	320	355	10167		22,2	256	280	10024		21,4	214	228	9740		21,0
5,04	0,0464	347	400	10558		22,7	288	318	10130		21,8	230	250	9955		21,1	193	203	9667		21,1
5,61	0,1542	312	355	10439		22,0	258	283	10050		21,3	207	225	9981		21,0	173	181	9602		21,5
6,27	0,1350	279	315	10342		21,5	231	251	9945		21,0	185	200	9906		21,0	155	161	9536		21,8
7,02	0,1183	249	280	10294		21,2	207	225	9983		20,8	165	174	9622		21,5	138	143	9484		22,3
7,89	0,1036	222	250	10331		20,8	184	200	9975		21,2	147	160	9975		22,0	123	132	9841		22,6
8,91	0,0900	196	211	9849		21,0	163	172	9667		21,6	130	135	9507		22,5	109	112	9407		23,0
10,1	0,0770	173	183	9725		21,5	143	150	9605		22,0	115	118	9469		22,9	96	98	9399		24,0
11,6	0,0656	151	160	9723		21,9	125	132	9681		22,5	100	110	10085		23,2	84	90	9867		25,2
12,5	0,0546	140	148	9628		22,2	116	121	9532		22,8	93	96	9434		24,4	78	90	10598		25,5
14,5	0,0467	121	132	10027		22,6	100	110	10085		23,2	80	90	10314		25,5	67	76	10443		27,0
15,7	0,0405	111	116	9572		23,0	92	96	9515		24,5	74	82	10191		26,3	62	75	11147		27,7
17,1	0,0355	102	110	9868		23,3	85	90	9777		25,0	68	77	10434		27,0	57	68	11038		28,5
18,7	0,0315	93	98	9571		24,3	77	90	10663		25,5	62	75	11107		27,8	52	64	11370		29,2
20,6	0,0272	85	91	9864		24,8	70	80	10418		26,5	56	68	11132		28,5	47	60	11695		30,1
22,8	0,0243	77	90	10773		25,8	63	75	10835		27,5	51	64	11521		29,5	42	55	11877		31,5

Potenze termiche / Thermal power / Thermische Grenzleistung PtN [kW]
(senza raffreddamento / Without cooling / ohne Kühlung)

104

1.9 Prestazioni riduttori

1.9 Gear unit ratings

1.9 Leistungen der Getriebe

RXP2 814

Calculation of gear - Service Factor:
3.6-ISO; 3.8-DIN; 2.0 - AGMA

Calculation of bearings - hours min - ISO 281
Output axis: 100.000 - Others axis: 50.000



810

ir	J1 kgm ²	n ₁ = 1750 min ⁻¹					n ₁ = 1450 min ⁻¹					n ₁ = 1160 min ⁻¹					n ₁ = 970 min ⁻¹				
		n ₂ min ⁻¹	P kW	T _N Nm	Fr ₂ kN	Fa ₂ kN	n ₂ min ⁻¹	P kW	T _N Nm	Fr ₂ kN	Fa ₂ kN	n ₂ min ⁻¹	P kW	T _N Nm	Fr ₂ kN	Fa ₂ kN	n ₂ min ⁻¹	P kW	T _N Nm	Fr ₂ kN	Fa ₂ kN
4,60	0,0506	380	560	13501		11,2	315	460	13388		9,8	252	362	13174		8,7	211	315	13701		7,6
5,12	0,0478	342	500	13409	A richiesta / On request / Auf Anfrage	10,8	283	410	13261	A richiesta / On request / Auf Anfrage	9,4	227	319	12886	A richiesta / On request / Auf Anfrage	9,0	189	261	12604	A richiesta / On request / Auf Anfrage	9,0
5,70	0,2742	307	450	13444		10,1	254	363	13085		9,1	203	280	12620		9,2	170	231	12451		9,6
6,37	0,2402	275	400	13342	9,6	228	317	12778	9,3	182	250	12580	9,6	152	203	12198	10,7				
7,13	0,2104	245	355	13260	9,6	203	280	12622	9,5	163	225	12678	10,5	136	178	12015	11,6				
8,01	0,1843	218	315	13225	9,5	181	250	12668	10,0	145	200	12668	11,3	121	160	12120	12,5				
9,05	0,1599	193	260	12350	9,8	160	225	12879	10,3	128	166	11891	12,2	107	137	11748	13,5				
10,3	0,1368	170	226	12182	10,7	141	184	11970	12,0	113	145	11775	13,2	94	120	11660	14,3				
11,8	0,1164	148	200	12349	11,7	123	160	11923	12,8	98	132	12296	13,5	82	110	12253	15,1				
12,7	0,0972	138	184	12202	12,3	115	147	11790	13,3	92	116	11616	14,7	77	99	11785	16,0				
13,6	0,0831	128	166	11886	12,8	106	136	11716	14,0	85	110	11854	15,2	71	94	12049	16,9				
16,0	0,0719	110	141	11768	13,7	91	115	11647	15,0	73	95	11995	16,5	61	90	13590	16,9				
17,4	0,0631	101	132	12031	14,4	83	110	12100	15,5	67	90	12375	17,2	56	79	12941	18,2				
19,0	0,0561	92	118	11739	14,8	76	99	11881	16,9	61	90	13542	17,2	51	75	13496	19,0				
21,0	0,0484	84	110	12074	15,6	69	93	12254	17,3	55	79	12999	18,3	46	69	13724	19,8				
23,2	0,0431	75	98	11967	16,5	62	90	13210	17,7	50	75	13760	19,0	42	65	14152	20,5				

Potenze termiche / Thermal power / Thermische Grenzleistung PtN [kW]

(senza raffreddamento / Without cooling / ohne Kühlung)

127



RXP2 816

Calculation of gear - Service Factor:
3.6-ISO; 3.8-DIN; 2.0 - AGMA

Calculation of bearings - hours min - ISO 281
Output axis: 100.000 - Others axis: 50.000



1130

ir	J1 kgm ²	n ₁ = 1750 min ⁻¹					n ₁ = 1450 min ⁻¹					n ₁ = 1160 min ⁻¹					n ₁ = 970 min ⁻¹				
		n ₂ min ⁻¹	P kW	T _N Nm	Fr ₂ kN	Fa ₂ kN	n ₂ min ⁻¹	P kW	T _N Nm	Fr ₂ kN	Fa ₂ kN	n ₂ min ⁻¹	P kW	T _N Nm	Fr ₂ kN	Fa ₂ kN	n ₂ min ⁻¹	P kW	T _N Nm	Fr ₂ kN	Fa ₂ kN
4,63	0,0913	378	810,0	19641		25,0	313	710,0	20778		21,5	251	560,0	20486		19,8	210	450,0	19686		19,6
5,14	0,0859	340	730,3	19676	A richiesta / On request / Auf Anfrage	23,5	282	630,0	20486	A richiesta / On request / Auf Anfrage	21,0	226	471,3	19157	A richiesta / On request / Auf Anfrage	20,0	189	400,0	19443	A richiesta / On request / Auf Anfrage	19,6
5,72	0,4875	306	658,5	19745		22,0	253	560,0	20265		20,5	203	414,0	18727		20,3	169	355,0	19204		20,0
6,38	0,4271	274	584,4	19546	21,3	227	468,9	18928	20,7	182	363,8	18356	20,3	152	315,0	19007	20,8				
7,14	0,3741	245	509,5	19066	21,3	203	410,6	18544	20,8	162	319,5	18037	21,2	136	262,5	17722	22,8				
8,02	0,3277	218	450,0	18914	21,3	181	358,7	18196	20,8	145	280,0	17754	22,5	121	230,2	17456	24,0				
9,06	0,2843	193	400,0	18977	21,3	160	315,0	18036	22,0	128	250,0	17893	23,8	107	201,3	17230	25,2				
10,3	0,2432	170	333,2	17955	21,5	141	280,0	18210	23,0	113	225,0	18291	24,4	94	175,4	17052	26,5				
11,0	0,2070	159	315,0	18141	22,1	132	251,3	17467	23,9	106	200,0	17376	25,6	88	163,4	16977	27,3				
12,6	0,1728	138	280,0	18546	22,8	115	225,0	17986	25,0	92	170,1	16997	26,8	77	141,1	16861	28,3				
13,6	0,1478	129	250,0	17830	24,2	107	200,0	17215	26,0	85	160,0	17215	27,6	71	132,0	16984	30,2				
15,9	0,1279	110	205,8	17189	25,8	91	168,7	17005	27,0	73	133,9	16872	30,0	61	117,8	17751	32,0				
17,4	0,1122	101	200,0	18186	25,8	84	160,0	17559	28,0	67	132,0	18108	31,0	56	110,7	18161	33,3				
19,0	0,0997	92	171,5	17061	27,2	76	140,9	16917	29,3	61	118,4	17769	32,0	51	110,0	19742	33,9				
20,9	0,0860	84	160,0	17513	27,2	69	132,0	17437	30,6	56	110,8	18296	33,0	46	97,5	19253	35,0				
23,1	0,0767	76	140,2	16998	29,2	63	121,2	17735	31,6	50	110,0	20120	33,7	42	90,8	19861	36,0				

Potenze termiche / Thermal power / Thermische Grenzleistung PtN [kW]

(senza raffreddamento / Without cooling / ohne Kühlung)

160

1.9 Prestazioni riduttori

1.9 Gear unit ratings

1.9 Leistungen der Getriebe

RXP2 818

Calculation of gear - Service Factor:
3.6-ISO; 3.8-DIN; 2.0 - AGMA

Calculation of bearings - hours min - ISO 281
Output axis: 100.000 - Others axis: 50.000



1550

ir	J1 kgm ²	n ₁ = 1750 min ⁻¹					n ₁ = 1450 min ⁻¹					n ₁ = 1160 min ⁻¹					n ₁ = 970 min ⁻¹				
		n ₂ min ⁻¹	P kW	T _N Nm	Fr ₂ kN	Fa ₂ kN	n ₂ min ⁻¹	P kW	T _N Nm	Fr ₂ kN	Fa ₂ kN	n ₂ min ⁻¹	P kW	T _N Nm	Fr ₂ kN	Fa ₂ kN	n ₂ min ⁻¹	P kW	T _N Nm	Fr ₂ kN	Fa ₂ kN
4,46	0,1620	392	1000	23362	A richiesta / On request / Auf Anfrage	45,9	325	837,4	23611	45,0	260	665,7	23463	A richiesta / On request / Auf Anfrage	43,6	218	560,0	23603	A richiesta / On request / Auf Anfrage	42,5	
4,94	0,1525	354	936,5	24231		45,8	294	800,0	24981	45,0	235	631,3	24642		43,6	196	515,5	24063		42,7	
5,48	0,8670	320	900,0	25820		45,7	265	750,4	25982	45,0	212	596,9	25834		43,8	177	500,0	25879		42,9	
6,42	0,7594	273	807,6	27148		45,6	226	710,0	28805	45,0	181	560,0	28400		44,0	151	450,0	27291		43,8	
7,16	0,6653	245	755,4	28318		45,6	203	640,5	28978	45,2	162	509,3	28803		44,5	136	415,8	28121		44,6	
8,01	0,5827	219	710,0	29787		45,7	181	630,0	31900	45,5	145	500,0	31646		45,5	121	400,0	30276		45,4	
9,00	0,5056	194	650,4	30676		45,7	161	560,0	31877	45,5	129	421,0	29956		45,6	108	355,0	30208		45,8	
10,18	0,4325	172	582,6	31067		45,5	142	500,0	32178	45,5	114	368,7	29660		45,7	95	315,0	30304		46,0	
11,6	0,3681	151	504,0	30600		45,5	125	408,9	29963	45,5	100	320,7	29375		46,0	84	280,0	30670		46,6	
12,4	0,3073	141	467,9	30410		45,5	117	400,0	31376	45,8	94	315,0	30886		46,3	78	250,0	29314		46,6	
14,3	0,2628	122	400,0	30024		45,5	101	325,7	29505	46,0	81	256,7	29068		47,2	68	225,0	30469		49,3	
15,5	0,2274	113	368,0	29822		45,8	94	315,0	30809	46,2	75	250,0	30564		48,2	63	200,0	29241		50,1	
18,2	0,1995	96	315,0	30100		46,0	79	253,1	29189	47,5	64	202,6	29206		50,0	53	178,8	30824		53,0	
19,9	0,1773	88	281,7	29435		46,5	73	231,0	29131	48,3	58	200,0	31527		51,5	49	168,4	31745		54,6	
21,9	0,1529	80	255,1	29314		47,3	66	209,7	29083	49,5	53	178,8	30996		53,0	44	160,0	33170		56,2	
24,3	0,1364	72	230,2	29288		48,3	60	200,0	30711	51,0	48	164,0	31478		54,5	40	138,0	31676		57,0	

Potenze termiche / Thermal power / Thermische Grenzleistung PtN [kW]

(senza raffreddamento / Without cooling / ohne Kühlung)

195

RXP2 820

Calculation of gear - Service Factor:
3.6-ISO; 3.8-DIN; 2.0 - AGMA

Calculation of bearings - hours min - ISO 281
Output axis: 100.000 - Others axis: 50.000



2200

ir	J1 kgm ²	n ₁ = 1750 min ⁻¹					n ₁ = 1450 min ⁻¹					n ₁ = 1160 min ⁻¹					n ₁ = 970 min ⁻¹				
		n ₂ min ⁻¹	P kW	T _N Nm	Fr ₂ kN	Fa ₂ kN	n ₂ min ⁻¹	P kW	T _N Nm	Fr ₂ kN	Fa ₂ kN	n ₂ min ⁻¹	P kW	T _N Nm	Fr ₂ kN	Fa ₂ kN	n ₂ min ⁻¹	P kW	T _N Nm	Fr ₂ kN	Fa ₂ kN
4,44	2,0091	394	1629,2	37934	A richiesta / On request / Auf Anfrage	59,8	326	1400,0	39342	60,3	261	1120,0	39342	A richiesta / On request / Auf Anfrage	59,0	218	938,6	39428	A richiesta / On request / Auf Anfrage	58,0	
4,94	1,7600	354	1600,0	41418		60,8	293	1295,2	40464	60,6	235	1050,8	41036		59,2	196	900,0	42032		58,3	
5,50	1,5417	318	1453,2	41872		61,8	264	1250,0	43469	60,7	211	1000,0	43469		59,5	176	837,0	43510		58,6	
6,13	1,3505	285	1319,5	42398		61,3	236	1120,0	43433	60,2	189	900,0	43627		59,0	158	758,8	43987		58,4	
7,26	1,1830	241	1130,7	43001		60,2	200	949,0	43558	59,3	160	767,7	44045		58,5	134	646,6	44364		58,6	
8,16	1,0363	214	1015,3	43403		59,6	178	850,3	43870	58,8	142	710,0	45789		58,5	119	579,0	44655		59,0	
9,22	0,8990	190	905,3	43716		59,0	157	757,7	44158	58,3	126	630,0	45895		58,7	105	516,0	44953		59,4	
9,82	0,7691	178	854,0	43926		58,8	148	713,7	44305	58,3	118	577,0	44774		59,0	99	500,0	46399		59,8	
11,2	0,6546	156	755,0	44300		58,3	129	630,9	44677	58,7	104	510,2	45162		59,5	87	450,0	47636		60,5	
12,9	0,5464	136	661,6	44673		58,5	113	560,0	45636	59,3	90	450,0	45840		60,2	75	376,4	45853		61,1	
15,0	0,4674	117	574,5	45146		59,0	97	500,0	47421	60,0	77	400,0	47421		61,0	65	326,1	46232		62,0	
16,3	0,4045	108	532,4	45370		59,5	89	450,0	46283	60,3	71	359,0	46154		61,4	60	315,0	48430		62,5	
17,7	0,3548	99	500,0	46401		59,8	82	410,7	46000	60,7	65	331,6	46425		62,0	55	280,0	46880		63,0	
19,4	0,3153	90	452,1	45912		60,2	75	378,9	46440	61,2	60	315,0	48260		62,3	50	256,5	46995		63,5	
21,3	0,2720	82	414,2	46292		60,7	68	355,0	47884	61,7	54	280,0	47210		63,0	45	234,7	47323		64,0	
23,6	0,2426	74	366,5	45383		60,7	61	315,0	47076	62,0	49	250,2	46740		63,5	41	210,8	47093		64,5	

Potenze termiche / Thermal power / Thermische Grenzleistung PtN [kW]

(senza raffreddamento / Without cooling / ohne Kühlung)

252



802-820

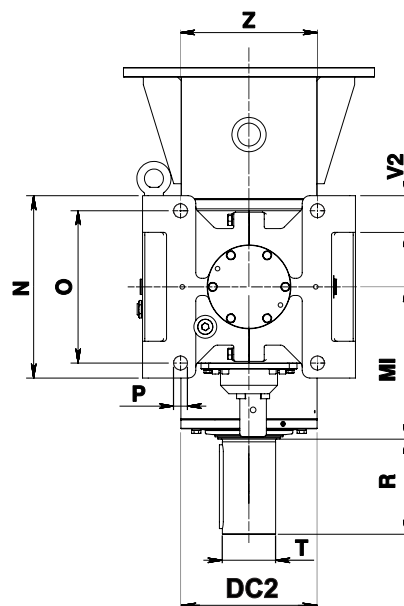
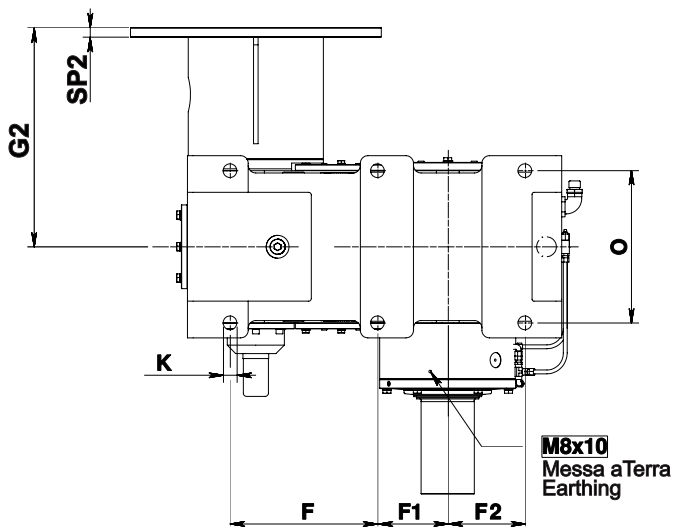
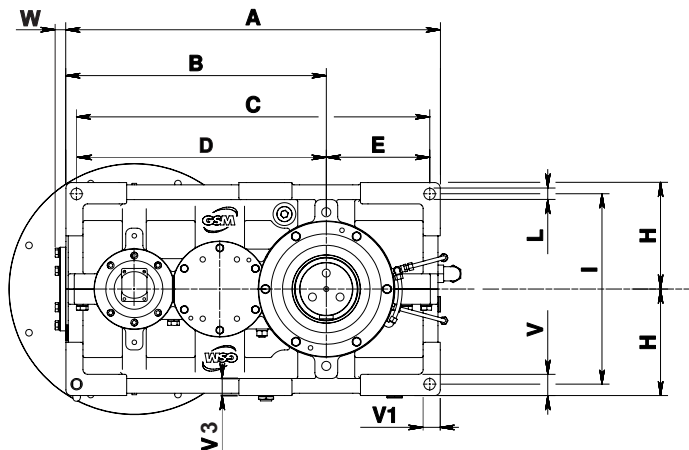

IEC ≤ 200 IEC ≥ 225

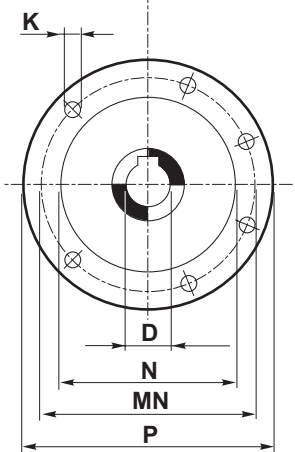

1.11 Dimensioni

1.11 Dimensions

1.11 Abmessungen

RX 800	Dimensioni generali / Dimensions / Allgemeine Abmessungen																						
	A	B	C	D	DC2	E	F	F1	F2	H _{h11}	I	K	L	N _{h11}	O	P	V	V1	V2	V3	W	Z	Kg
802	435	305	407	225	161	116	172.5	82.5	90	125	224	18	14	213	180	18	25	20	44.5	19	14	160	116
804	492	342	460	252	180	134	195	91	104	140	250	20	16	237	200	20	28	22.5	49	23	15	180	155
806	565	385	521	285	204	153	219.5	102.5	117	160	280	22	18	269	225	22	32	25	56.5	25	17	200	220
808	632	432	584	320	230	171	246	116	130	180	320	25	20	297	250	25	36	28	59.5	28	18	224	300
810	695	485	655	360	248	190	275	130	145	200	360	27	22	335	280	27	40	32	67.5	32	20	250	440
812	785	545	740	405	284	217.5	307.5	147.5	160	225	400	30	24	379	315	30	45	36	78.5	36	21	280	580
814	875	610	825	450	309	240	345	165	180	250	450	33	27	427	355	33	50	40	89	40	24	320	810
816	985	685	929	505	358	272	388	185	203	280	500	36	30	479	400	36	56	45	96.5	45	28	360	1130
818	1110	770	1046	570	410	308	437.5	207.5	230	315	560	39	35	541	450	39	63	50	114.5	48	29	400	1550
820	1245	865	1173	640	445	344	492.5	232.5	260	355	638	42	39	599	500	42	70	56	124	56	30	450	2200

1.12.1 - Estremità d'albero uscita

1.12.1 - Input shaft out

1.12.1 - Ende der Abtriebswelle

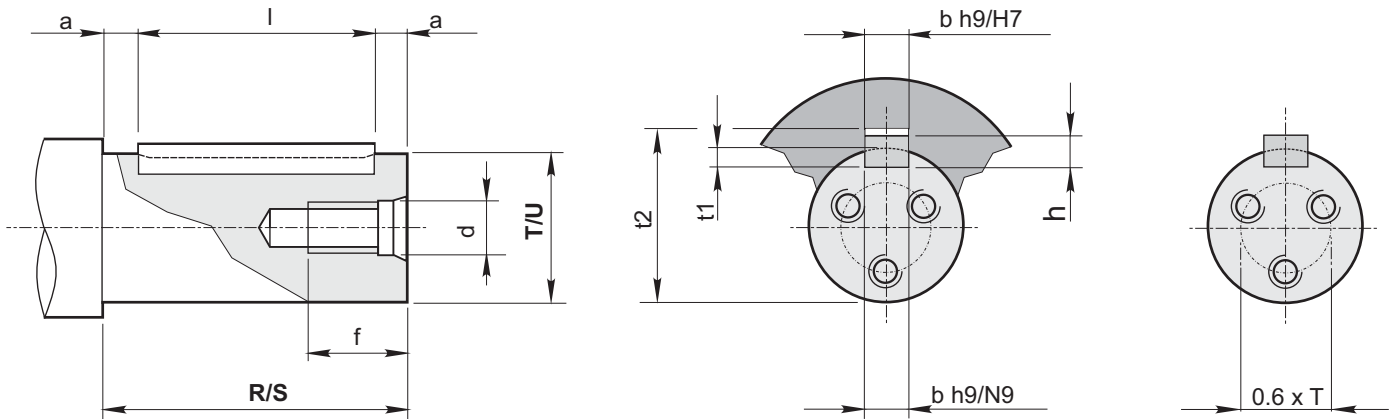

RX	Ø Albero Ø Shaft Ø Welle		Foro fil. testa Tapped hole Gewindebohrung Kopf		Cava Keyway Nut		Estremità d'albero Shaft end Wellenende		Linguetta Key Federkeil	
	T	MI	d	f	t ₁	t ₂	R _{a11}	a	bxhxl	
802	60 m6	165	M12	35	18	7	64.4	112	6	18x11x100
804	70 m6	182	M16	39	20	7.5	74.9	125	7.5	20x12x110
806	80 m6	206.5	M16	39	22	9	85.4	140	7.5	22x14x125
808	90 m6	227.5	M16	39	25	9	95.4	160	10	25x14x140
810	100 m6	256.5	M20	46	28	10	106.4	180	10	28x16x160
812	110 m6	290.5	M20	46	28	10	116.4	200	10	28x16x180
814	125 m6	330.5	M20	46	32	11	132.4	225	12.5	32x18x200
816	140 m6	368	M24	56	36	12	148.4	250	15	36x20x220
818	160 m6	450	M24	56	40	13	169.4	280	15	40x22x250
820	180 m6	500	M30	72	45	15	190.4	315	17.5	45x25x280

Estremità d'albero cilindriche secondo UNI 6397-68, DIN748, NFE 22.051, BS 4506-70, ISO/R 775/69, escluso corrispondenza R-S. Linguette secondo UNI6604-69, DIN6885 Bl. 1-68, NFE 27.656 e 22.175, BS 4235.1-72, ISO/R 773/69, escluso corrispondenza I.

Cylindrical shaft ends in accordance with UNI 6397-68, DIN748, NFE 22.051, BS 4506-70, ISO/R 775/69, excluding section R-S. Key according to UNI6604-69, DIN6885 Bl. 1-68, NFE 27.656 e 22.175, BS 4235.1-72, ISO/R 773/69, excluding section I.

Zylindrische Wellenenden gemäß UNI 6397-68, DIN748, NFE 22.051, BS 4506-70, ISO/R 775/69, ausgenommen Zuordnung R-S. Federkeile UNI6604-69, DIN6885 Bl. 1-68, NFE 27.656 und 22.175, BS 4235.1-72, ISO/R 773/69, ausgenommen Zuordnung I.

1.12.2 - Estremità d'albero entrata

1.12.2 - Input shaft end

1.12.2 - Ende der Antriebswelle

PAM		132	160	180	200	225	250	280	315	355
D F7/H7		38	42	48	55	60	65	75	80	100
P		300	350	350	400	450	550	550	660	800
MN		265	300	300	350	400	500	500	600	740
N G6		230	250	250	300	350	450	450	550	680
K		M12	M16	M16	M16	M16	M16	M16	M20	M20
SP2		16/16	18/18	18/18	20/20	20/20	20/20	20/20	24/24	30
G2	802	273	303	303	303					
	804		315	315	315	345				
	806		363	363	363	393				
	808			377	377	407	407	407		
	810				409	439	439	439		
	812					476	476	476	506	
	814						500	500	530	570
	816							546	576	616
818							597	627	667	
820								656	696	

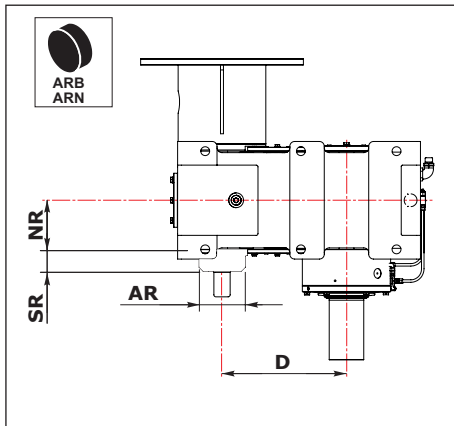
1.13 Accessori
1.13 Accessories
1.13 Zubehör
Antiretro
Backstop
Rücklaufsperre

RXP2 - CR				
	NR	SR	AR	D
802	90	41	72	225
804	100	57	80	252
806	112.5	66	90	285
808	125	57	100	320
810	140	58	110	360
812	157.5	63	120	405
814	177.5	86	130	450
816	200	81	150	505
818	225	67	170	570
820	250	97	180	640

U

ACC. - OPT - ACCESSORI E OPZIONI
ACC. - OPT - ACCESSORIES AND OPTIONS
ACC. - OPT - ZUBEHÖR UND OPTIONEN

Accessori - Dispositivi
ACC.

Accessories devices
ACC.

Zubehör - Vorrichtungen
ACC.

Accessories

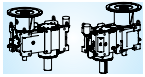

Possono essere forniti i seguenti *Some devices can optionally be* Folgende Zubehörteile und Vorrichtungen können geliefert werden:
accessori e dispositivi *provided*

Designation

- 1 Cooling
- 2 Backstop
- ACC6 Bearing lubrication
- ACC7. OIL LEVEL SWITCH
- 7A Vibration Sensor
- 7B Vibration SWITCH
- 7E TAP DRAIN
- 7F Breather with anti-humidity filter
- 7G OIL LEVEL dipstick
- HEATERS
- 9. PT 100 - SENSOR
- 7M Pressure switch
- ACC8 Sealing

On request

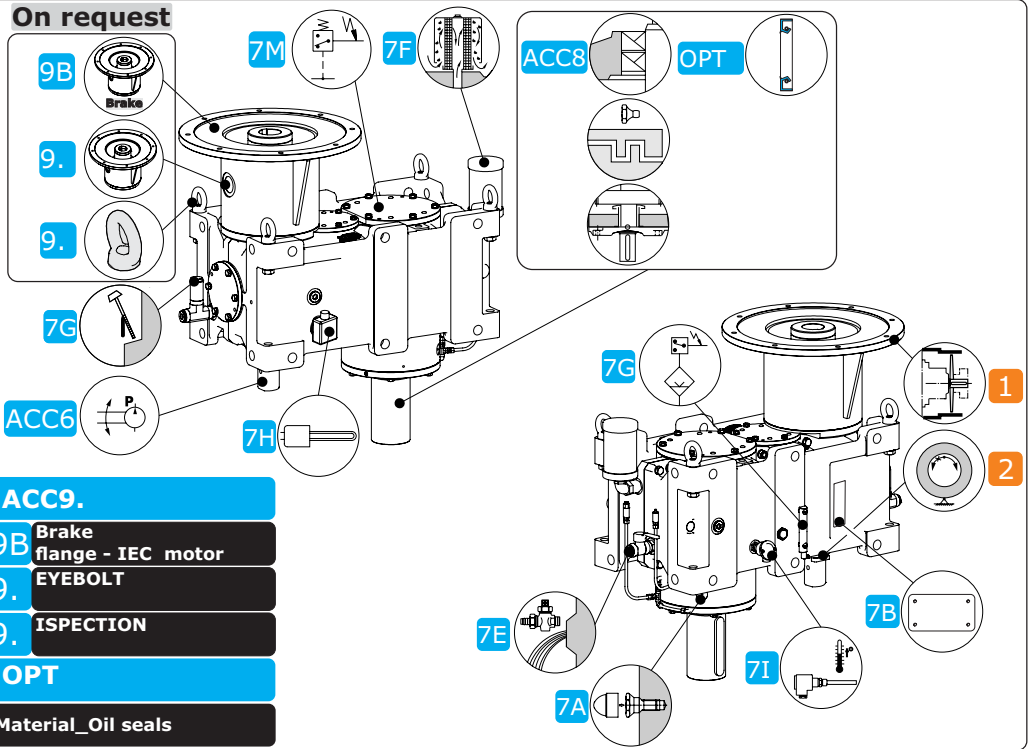

		ACC6	ACC6 - Accessori Lubrificazione Forzata BEARING	ACC6 - Accessories - <i>Forced</i> lubrification - BEARING	ACC6 - Zubehör Zwangsschmierung BEARING	BU2
ACC7-R	Hydraulic accessories	ACC7A	Accessori idraulici Vibration Sensor	<i>Hydraulic accessories</i> Vibration Sensor	Hydraulikzubehör Vibration Sensor	BU3
		ACC7B	Accessori idraulici Vibration SWITCH	<i>Hydraulic accessories</i> Vibration SWITCH	Hydraulikzubehör Vibration SWITCH	BU4
		ACC7E	Accessori idraulici DRAIN	<i>Hydraulic accessories</i> DRAIN	Hydraulikzubehör - DRAIN	BU5
		ACC7F	Accessori idraulici BREATHER	<i>Hydraulic accessories</i> BREATHER	Hydraulikzubehör BREATHER	BU6
		ACC7G	Accessori idraulici LEVEL	<i>Hydraulic accessories</i> LEVEL	Hydraulikzubehör - LEVEL	BU8
		ACC7H	Accessori idraulici HEATER	<i>Hydraulic accessories</i> HEATER	Hydraulikzubehör HEATER	BU16
		ACC7I1	Accessori idraulici TEMPERATURE SENSOR	<i>Hydraulic accessories</i> TEMPERATURE SENSOR	Hydraulikzubehör TEMPERATURE SENSOR	BU18
		ACC7M2	Accessori idraulici PRESSURE SWITCH	<i>Hydraulic accessories</i> PRESSURE SWITCH	Hydraulikzubehör PRESSURE SWITCH	BU26
ACC8-R		ACC8	ACC8 - Accessori - Tipo Tenute	ACC8 - Accessories - <i>Seal</i> Type	ACC8 - Zubehör - Typ von Dichtung	BU28
OPT		OPT	OPT - Opzioni - Materiale degli anelli di tenuta	OPT - Options - <i>Materials of</i> Seals	OPT - Optionen - Dichtungsstoffe	BU32
ACC9-R		ACC9.	ACC9. - Custom Accessories	ACC9. - Custom Accessories	ACC9. - Custom Accessories	BU34



2.0 - Lubrificazione forzata

2.0 - Forced lubrication

2.0 - Zwangsschmierung

ACC6	ACC6 - Accessori - Lubrificazione Forzata - BEARING	ACC6 - Accessories - Forced lubrication - BEARING	ACC6 - Zubehör - Zwangsschmierung - BEARING
-------------	--	--	--

ACC6

Bearing lubrication

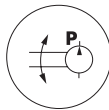

La lubrificazione dei cuscinetti sopra al livello dell'olio è garantita come segue:
- Olio

Per le condizioni di consegna fare riferimento alla sezione specifica.

Possono essere forniti i seguenti accessori e dispositivi:

The lubrication of the bearings above oil level is ensured as follows:
- Oil

For the delivery conditions refer to the specific paragraph.

Some devices can optionally be provided:

Die Schmierung der Lager, über den Öfüllstand hinaus, wird folgendermaßen gewährleistet:
- mit Öl

Bezüglich der Lieferbedingungen ist Bezug auf den spezifischen Abschnitt zu nehmen.

Folgende Zubehörteile und Vorrichtungen können geliefert werden:

Code Designation	Code ORDER	I	GB	DE
LFP2	---	= Pompa asservita - 5 l/min	= Shaft-driven pump - 5 l/min	= Nebenpumpe- 5 l/min

2.1 - Applicabilità

Attenzione LFP1 e LFP2:

1 - La pompa LFP1 & LFP2 è unidirezionale. L'accessorio può essere montato sul riduttore solo nel caso esso funzioni con unico senso di rotazione, il quale deve essere specificato in fase di ordine.

2 - Per applicabilità LFP...: consultare servizio tecnico.

2.1 - Application

Attention LFP1 e LFP2:

1 - *The LFP1 & LFP2 pump is a one-way pump. The accessory can be installed on the gearbox only if it works in a single direction of rotation, which must be specified in the order.*

2 - *For LFP... applicability: contact the technical service.*

2.1 - Applikation

Achtung LFP1 & LFP2:

1 - Die LFP1 & LFP2 ist eine einseitig gerichtete Pumpe. Das Zubehör kann nur am Getriebe montiert werden, wenn es mit einer einzigen Drehrichtung arbeitet, die bei der Bestellung angegeben werden muss.

2 - Für die LFP...Anwendungsmöglichkeit: sich an den technischen Kundendienst wenden.

2.2 - Pompa asservita

Questo sistema si realizza accoppiando la pompa direttamente all'albero del riduttore, dal quale prende il moto.

In questa famiglia di prodotti è utilizzata la pompa asservita LFP2.

2.2 - Shaft-driven pump

This system is created by coupling the pump directly to the gearbox shaft, which conveys motion.

This product family uses LFP2 interlocked pump.

2.2 - Nebenpumpe

Dieses System entsteht mittels direkter Kupplung der Pumpe an die Getriebewelle, von der sie angetrieben wird.

In dieser Produktfamilie kommt die Nebenpumpe LFP2 zum Einsatz.

LFP2

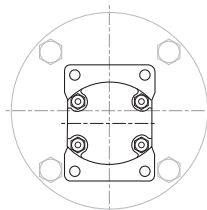
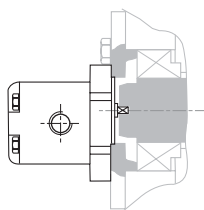

Pompa con portata di 5 l/min a 1500 rpm

Pump with 5 l/min capacity at 1500 rpm

Pumpe mit Durchsatz von 5 l/min bei 1500 U/min

ACC7A	Accessori idraulici - Vibration Sensor	Hydraulic accessories - Vibration Sensor	Hydraulikzubehör - Vibration Sensor
--------------	---	---	--

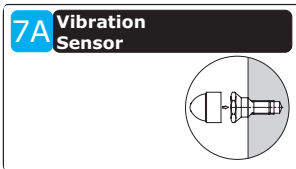

Predisposizione per installazione sensori di vibrazioni. La predisposizione è disponibile sia in ingresso che in uscita

Connection for vibration sensor installation. The connection is available as both input and output

Auslegung für die Installation der Schwingungssensoren. Diese Auslegung ist sowohl am Ein- als auch am Ausgang verfügbar

Possono essere forniti i seguenti accessori e dispositivi:

Some devices can optionally be provided:

Folgende Zubehörteile und Vorrichtungen können geliefert werden:

Code Designation	Code ORDER	I	GB	DE
A_PHZ2	---	= PREDISPOSIZIONE - Accelerometro - Uscita	= CONNECTION - Accelerometer - Output	= AUSLEGUNG - Beschleunigungsmesser - Ausgang



RXP2-CR

Size	Dimensions	Size	Dimensions
≤ 812		≥ 814	

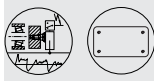

ACC7B	Accessori idraulici - Vibration SWITCH	Hydraulic accessories - Vibration SWITCH	Hydraulikzubehör - Vibration SWITCH
--------------	---	---	--

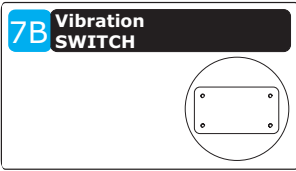

Predisposizione per installazione "Vibration Switch"

Connection for "Vibration Switch" installation

"Vibration Switch"

Auslegung für die Installation eines „Vibration Switch“

Possono essere forniti i seguenti accessori e dispositivi:

Some devices can optionally be provided:

Folgende Zubehörteile und Vorrichtungen können geliefert werden:

Code Designation	Code ORDER	I	GB	DE
B_PVS1	---	= PREDISPOSIZIONE - Vibration SWITCH - - Type1A	= CONNECTION for - Vibration SWITCH - - Type1A	=AUSLEGUNG - Vibration SWITCH - - Type1A
B_PVS2	---	= PREDISPOSIZIONE - Vibration SWITCH - - Type1B	= CONNECTION for - Vibration SWITCH - - Type1B	=AUSLEGUNG - Vibration SWITCH - - Type1B

RXP2-CR

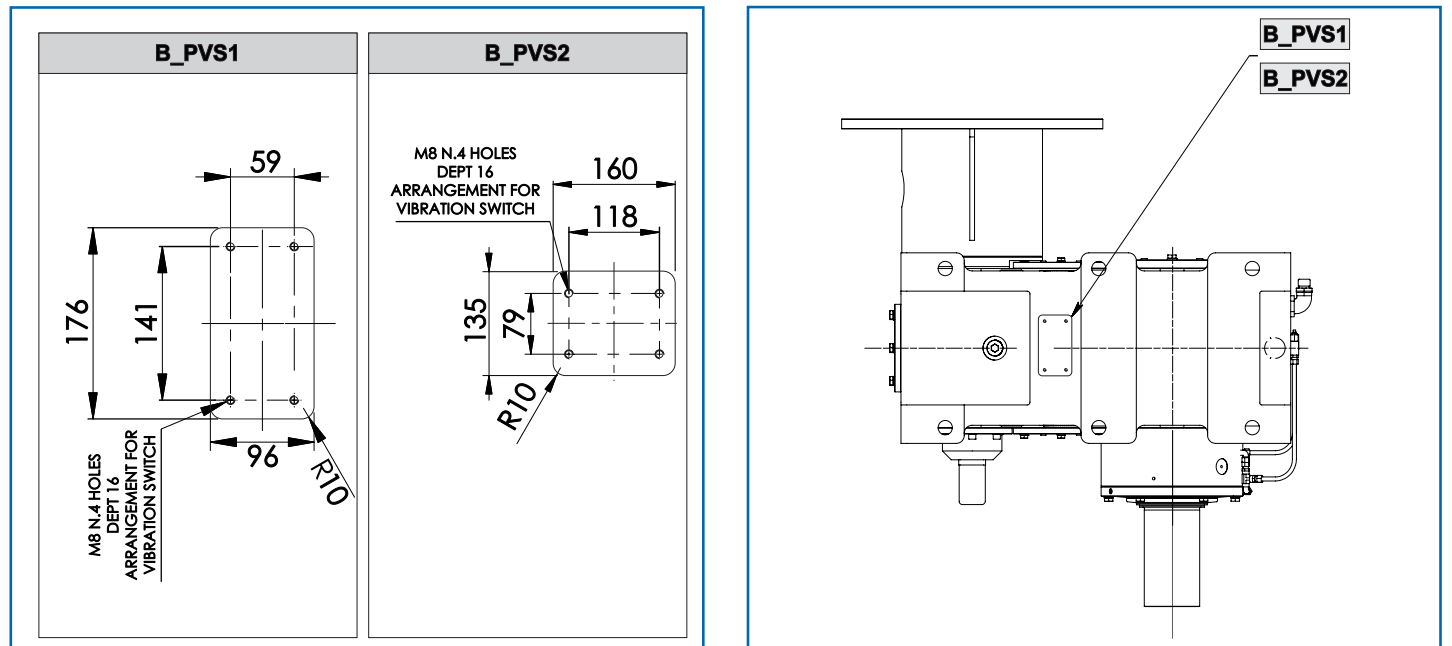

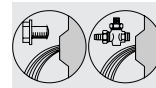

3.0 - Accessori idraulici

3.0 - Hydraulic accessories

3.0 - Hydraulikzubehör

ACC7E	Accessori idraulici - DRAIN	Hydraulic accessories - DRAIN	Hydraulikzubehör - DRAIN
--------------	--	--	-------------------------------------

7E TAP DRAIN

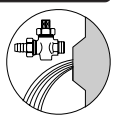

Per facilitare le operazioni di svuotamento del riduttore

To facilitate the gearbox emptying operations

Für eine einfachere Entleerung des Getriebes

Possono essere forniti i seguenti accessori e dispositivi:

Some devices can optionally be provided:

Folgende Zubehörteile und Vorrichtungen können geliefert werden:

Code Designation	Code ORDER	I	GB	DE
E_D5	7980380001	= Rubinetto olio	= Oil tap	= Ölhahn
E_D5	7980120002			
E_D5	7980340002			
E_D5	7981000003			

Applicabilità

Application

Applikation

	CODE ORDER	DESCRIPTION	Note
802	7980380001	KIT RUBINETTO G3/8"	
804	7980120002	KIT RUBINETTO G1/2"	
806	7980120002	KIT RUBINETTO G1/2"	
808	7980120002	KIT RUBINETTO G1/2"	
810	7980340002	KIT RUBINETTO G3/4"	
812	7980340002	KIT RUBINETTO G3/4"	
814	7980340002	KIT RUBINETTO G3/4"	
816	7981000003	KIT RUBINETTO G1"	
818	7981000003	KIT RUBINETTO G1"	
820	7981000003	KIT RUBINETTO G1"	

TECHNICAL DATASHEET

CARATTERISTICHE GENERALI
- Ottone OT/58

GENERAL FEATURES
- Brass OT/58

ALLGEMEINE EIGENSCHAFTEN
- Messing OT/58

Dimensioni

Dimensions

Abmessungen

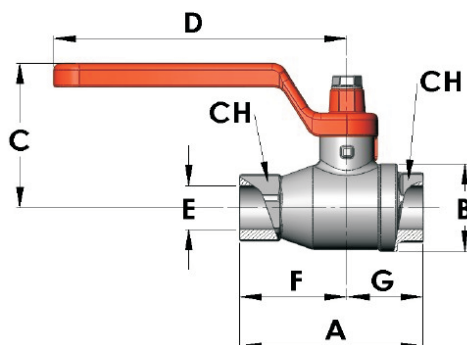

Code Designation	Code ORDER	Thread	A	B	C	D	E	F	G	CH
E_D5	7980380001	3/8"	60	26	40	80	10	29.7	30	21
E_D5	7980120002	1/2"	75	33	50	89	15	37.5	38	25
E_D5	7980340002	3/4"	80	42	59	113	20	40.0	40	31
E_D5	7981000003	1"	90	50	63	113	25	45.2	45	38



ACC7F	Accessori idraulici - BREATHER	Hydraulic accessories - BREATHER	Hydraulikzubehör - BREATHER
--------------	---------------------------------------	---	------------------------------------

7F Breather with anti-umidity filter

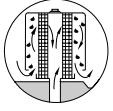

Utilizzare un filtro a tre stadi per rimuovere la contaminazione da umidità prima che possano entrare nel riduttore.

Use three-stage filtration to remove moisture solid contamination before they can enter the gearbox.

Verwenden Sie einen dreistufigen Filter, um Feuchtigkeitsverunreinigungen zu entfernen, bevor sie in Getriebe gelangen können.

Possono essere forniti i seguenti accessori e dispositivi:

Some devices can optionally be provided:

Folgende Zubehörteile und Vorrichtungen können geliefert werden:

Code Designation	Code ORDER	I	GB	DE
F_T5A	530100001	= Tappo sfiato speciale con filtro antiumidità - Type5A	= special breather with anti-umidity filter - Type5A	= Spezieller Entlüftungsstopfen mit Entfeuchtungsfiler - Type5A

TECHNICAL DATASHEET



DESCRIZIONE

Gli sfiati aria Air F_T5A utilizzano una filtrazione a tre stadi per rimuovere l'umidità e la contaminazione solida prima che possano entrare nel serbatoio

Nella prima fase l'aria passa attraverso un filtro che trattiene le particelle solide maggiori di 2µm. L'aria attraversa poi un diffusore per assicurare la massima efficienza nel passaggio attraverso il silica gel.

Nella fase successiva, l'umidità viene trattenuta nel passaggio dell'aria attraverso un letto di silica gel - un materiale ad altissima capacità di assorbimento.

Una volta deumidificata, l'aria attraversa un secondo filtro da 2µm ed entra nel serbatoio, decontaminata ed asciutta.

L'aria immessa nel serbatoio è decontaminata e asciutta.

Quella che ne esce rigenera parzialmente il silica gel ed il filtro per la contaminazione solida, prolungando la vita dello sfiato.

Il silica gel è chimicamente inerte, non tossico, non-deliquestente e non-corrosivo.

La sua struttura interna consiste di pori microscopici interconnessi tra loro che permettono un assorbimento fino al 40% del suo peso.

Al raggiungimento della saturazione, il silica gel varia colore da giallo a blu per indicare la necessità di sostituzione.

Caratteristiche costruttive generali

I modelli sono in robusta plastica ABS e in Plexiglas rinforzato.

– Portata nominale: 1.000 l/min;

– Filtrazione solida: 2µm;

– Assorbimento silica gel fino al 40% del proprio peso in acqua;

– TEMPERATURA DI ESERCIZIO:
Da -30°C a 100°C.

DESCRIPTION

Air F_T5A air vents use a three-stage filtration to remove moisture and solid contamination before they reach the tank.

In the first phase, air flows through a filter that retains solid particles greater than 2µm. Then, the air flows through a diffuser to ensure maximum efficiency during the passage through silica gel.

In the following phase, the moisture of the flowing air is absorbed by a layer of silica gel - a highly absorbing material.

Once dehumidified, the air flows through a second 2-µm filter and enters the tank decontaminated and dry.

The tank inlet air is decontaminated and dry. The outlet air partially regenerates the silica gel and solid contamination filter, thus extending the life of the vent.

The silica gel is chemically inert, non-toxic, non-deliquestent and non-corrosive. Its internal structure consists of microscopic pores interconnected to one another, allowing for an absorption up to 40% of its weight.

Upon reaching saturation, the silica gel from yellow turns blue, indicating that it must be replaced.

General manufacturing features

The models are in sturdy ABS plastic and reinforced Plexiglas.

– *Nominal flow rate: 1,000 l/min;*

– *Solid filtration: 2 µm;*

– *Silica gel absorption up to 40% of its weight in water;*

– *OPERATING TEMPERATURE:
-30°C to 100°C.*

BESCHREIBUNG

Die Entlüftungen Air F_T5A verwenden eine dreistufige Filtration, um die Feuchtigkeit und feste Schmutzteile zu entfernen, bevor sie in den Tank gelangen können.

In der ersten Phase strömt die Luft durch einen Filter, die Feststoffpartikel zurückhält, die größer sind als 2µm sind.

Die Luft durchströmt dann einen Diffusor, um eine maximale Effizienz beim Durchströmen des Kieselgels zu gewährleisten.

In der nächsten Phase wird die Feuchtigkeit im Durchströmen der Luft durch ein Bett aus Kieselgel zurückgehalten. Kieselgel ist ein Material mit sehr hoher Saugfähigkeit.

Nach der Entfeuchtung durchströmt die Luft einen zweiten Filter 2 µm und gelangt dekontaminiert und trocken in den Tank.

Die in den Tank eingelassene Luft ist dekontaminiert und trocken.

Die aus dem Tank austretende Luft regeneriert teilweise das Kieselgel und den Filter von festem Schutz und verlängert die Lebensdauer der Entlüftung.

Das Kieselgel ist chemisch inert, ungiftig, verflüssigt sich nicht und ist nicht korrosiv. Seine innere Struktur besteht aus miteinander verbundenen mikroskopischen Poren, die eine Absorption von bis zu 40 % seines Gewichts ermöglichen.

Allgemeine Konstruktionsmerkmale

Die Modelle sind aus robustem ABS-Kunststoff und verstärktem Plexiglas gefertigt.

– Nenndurchfluss: 1.000 l/min;

– Feststofffiltration: 2 µm;

– Absorption von Kieselgel bis zu 40 % seines Gewichts in Wasser;

– BETRIEBSTEMPERATUR:
Von -30 °C bis 100 °C.

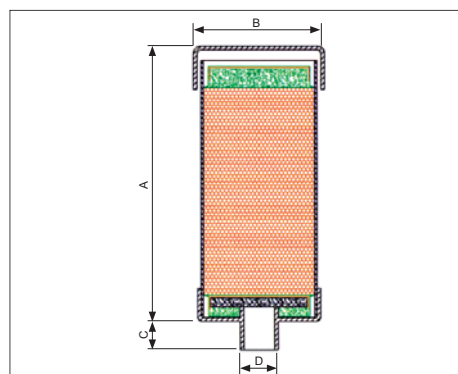

Code Designation	Code ORDER	GAS	A	ø B	C	Kg	max H2O (l)
F_T5A	5301000001	1"	205	127	32	1.7	0.5

BU

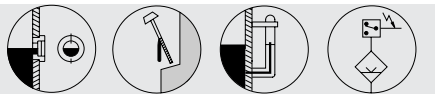

3.0 - Accessori idraulici

3.0 - Hydraulic accessories

3.0 - Hydraulikzubehör

ACC7G	Accessori idraulici - LEVEL	Hydraulic accessories - LEVEL	Hydraulikzubehör - LEVEL
--------------	------------------------------------	--------------------------------------	---------------------------------

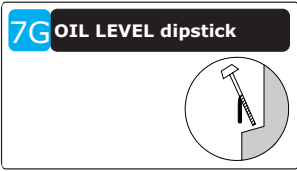

Per controllare il livello dell'olio nel riduttore, può essere fornito una astina di livello per controllo visivo del livello olio.

To control the oil level in the gear unit, an oil level dipstick is provided

Für die Sichtkontrolle des Füllstands des sich im Getriebe befindlichen Öls kann einen Messstab geliefert werden.

Possono essere forniti i seguenti accessori e dispositivi:

Some devices can optionally be provided:

Folgende Zubehörteile und Vorrichtungen können geliefert werden:

Code Designation	Code ORDER	I	GB	DE
G L2A	3140380003	= Asta livello olio - Type2A	= Oil dipstick - Type2A	= Ölmesstab - Type2A
G L2A	3140120014	= Asta livello olio - Type2A	= Oil dipstick - Type2A	= Ölmesstab - Type2A
G L2A	3140340003	= Asta livello olio - Type2A	= Oil dipstick - Type2A	= Ölmesstab - Type2A
G L2A	3141000003	= Asta livello olio - Type2A	= Oil dipstick - Type2A	= Ölmesstab - Type2A

Applicabilità

Application

Applikation

	CODE ORDER*	DESCRIPTION	Note
802	3140380003	TAPPO DI LIVELLO CON ASTINA 3/8" GAS	
804	3140120014	TAPPO DI LIVELLO CON ASTINA 1/2" GAS	
806	3140120014	TAPPO DI LIVELLO CON ASTINA 1/2" GAS	
808	3140120014	TAPPO DI LIVELLO CON ASTINA 1/2" GAS	
810	3140340003	TAPPO DI LIVELLO CON ASTINA 3/4" GAS	
812	3140340003	TAPPO DI LIVELLO CON ASTINA 3/4" GAS	
814	3140340003	TAPPO DI LIVELLO CON ASTINA 3/4" GAS	
816	3141000003	TAPPO DI LIVELLO CON ASTINA 1" GAS	
818	3141000003	TAPPO DI LIVELLO CON ASTINA 1" GAS	
820	3141000003	TAPPO DI LIVELLO CON ASTINA 1" GAS	

TECHNICAL DATASHEET

DESCRIZIONE

Tappo filettato con asta di livello incorporata.
A richiesta è possibile fornire con tacche di minimo e massimo e lunghezze diverse.

DESCRIPTION

Threaded plug with integrated dipstick.
On request, it is possible to receive it with min. and max. notches and in different lengths.

BESCHREIBUNG

Gewindeverschluss mit integriertem Messstab.
Auf Anfrage ist es möglich, ihn mit min. und max. Kerben und verschiedenen Längen zu erhalten.

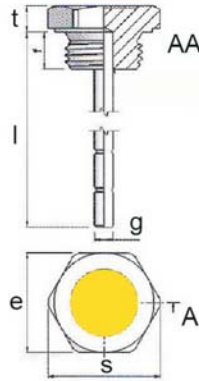
Dimensioni**Dimensions****Abmessungen**

Code Designation	Code ORDER	GAS	t	f	l	g	e	S	Kg
G L2A	3140380003	3/8"	7	10	—	5	22	24.5	
G L2A	3140120014	1/2"	7	10	—	5	27	30.5	
G L2A	3140340003	3/4"	8	12	—	5	32	36	
G L2A	3141000003	1"	8	14	—	5	40	44.5	

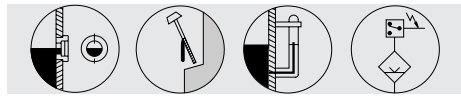

ACC7G	Accessori idraulici - LEVEL	Hydraulic accessories - LEVEL	Hydraulikzubehör - LEVEL
--------------	------------------------------------	--------------------------------------	---------------------------------

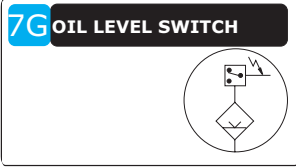

Per controllare il livello dell'olio nel riduttore, può essere fornito un interruttore di livello olio. L'interruttore può far scattare un allarme quando il livello dell'olio scende al di sotto di un valore specifico

To control the oil level in the gear unit, an oil level switch can be provided. The switch can trigger an alarm signal when the oil level falls beneath a specified

Für die Füllstandkontrolle des sich im Getriebe befindlichen Öls kann ein Ölfüllstandschalter geliefert werden. Dieser Schalter kann einen Alarm auslösen, sobald der Ölfüllstand unter einen bestimmten Wert sinkt

Possono essere forniti i seguenti accessori e dispositivi:

Some devices can optionally be provided:

Folgende Zubehörteile und Vorrichtungen können geliefert werden:

Code Designation	Code ORDER	I	GB	DE
G_L4A	4411270001	= Livello stato visivo - Type4A- NO	= Level switch with sight window - Type4A- NO	= Schauglas - Type4A- NO
G_L5D	4411500001	= Livello stato a galleggiante - Type5D	= Float level switch - Type5D	= Pegelwächter - Type5D

TECHNICAL DATASHEET



G_L4A



Indicatori di livello a colonna

Pillar level gauges

Säulen-Füllstandanzeigen

MATERIALE

Tecnopolimero trasparente a base poliammidica (PA-T). Alta resistenza a urti, solventi, oli additivati, idrocarburi alifatici e aromatici, benzine, nafta, esteri fosforici. Evitare il contatto con alcool o con miscele di lavaggio contenenti alcool.

MATERIAL

Polyamide-based transparent engineering polymer (PA-T). High resistance to shocks, solvents, allied oil, aliphatic and aromatic hydrocarbons, petrol, naphtha, phosphoric esters. Avoid any contact with alcohol or washing mixtures containing alcohol.

MATERIAL

Transparentes Technopolymer auf Polyamidbasis (PA-T). Hohe Festigkeit gegenüber Stößen, Lösungsmitteln, mit Zusatzstoffen bereicherten Ölen, aliphatischen und aromatischen Kohlenwasserstoffen, Benzin, Dieselmotortreibstoff, Phosphorsäureestern. Der Kontakt mit Alkohol oder Reinigungsgemischen, die Alkohol enthalten, ist zu vermeiden.

VITI, DADI E RONDELLE

Acciaio zincato lucido.

SCREWS, NUTS AND WASHERS

Polished galvanised steel.

SCHRAUBEN, MUTTERN UND UNTERLEGSCHLEIBEN

Verzinkter Stahl, glänzend.

GUARNIZIONI DI TENUTA

OR gomma sintetica NBR. Rugosità della superficie di appoggio della guarnizione Ra = 3 µm.

SEALS

NBR synthetic rubber O-ring. Seal resting surface roughness Ra = 3 µm.

DICHTUNGEN

O-Ringe aus synthetischem Kautschuk NBR. Rauheit der Auflagefläche der Dichtung Ra = 3 µm.

GALLEGGIANTE

Tecnopolimero espanso a base poliammidica (PA), colore nero, incorporante un elemento magnetico per l'attivazione del contatto elettrico quando il galleggiante raggiunge la soglia di allarme posta a circa 50 mm sopra l'asse del dado inferiore (dati riferiti a olio minerale tipo CB68, secondo ISO 3498, temperatura 23°C).

FLOAT

Black polyamide-based engineering plastic foam (PA), including a magnetic element to enable the electric contact once the float reaches the warning threshold located at about 50 mm above the axis of the lower nut (data concerning CB68 mineral oil, according to ISO 3498, temperature 23°C).

SCHWIMMER

Schaum-Technopolymer auf Polyamidbasis (PA), schwarz, mit integriertem magnetischen Element zur Aktivierung des elektrischen Kontakts, wenn der Schwimmer die auf ungefähr 50 mm oberhalb der Achse der unteren Mutter gesetzte Alarmschwelle erreicht (auf Mineralöl-Typ CB68, nach ISO 3498, Temperatur 23 °C bezogene Daten).

SQUADRETTA CON SENSORE

A perfetta tenuta stagna in tecnopolimero a base polipropilena (PP), colore nero, incorporante il relé (reed) con due conduttori cablati al connettore bipolare.

BRACKET WITH SENSOR

Black, watertight polypropylene-based engineering polymer (PP), including the relay (reed) with two conductors wired to the bipolar connector.

BEFESTIGUNGSWINKEL MIT SENSOR

Mit perfekter Abdichtung aus Technopolymer auf Polyamidbasis (PP), schwarz, im Relais (reed) integriert mit zwei an den zweipoligen Steckern verkabelten Leitern.

TECHNICAL DATASHEET

CONNETTORE BIPOLARE ORIENTABILE

Con pressacavo e portacontatti incorporati. Uscita frontale o laterale (dx o sx) che offre una completa protezione contro getti d'acqua (grado di protezione IP 65 come da tabella IEC 529

ADJUSTABLE BIPOLAR CONNECTOR

Cable entry and contact holder included. Front or side (RH or LH) output providing complete protection against water jets (IP 65 protection level according to IEC 529 table)

AUSRICHTBARER ZWEIPOLIGER STECKER

Mit Kabelverschraubung und eingebauten Kontaktfassungen. Frontale und seitlicher Ausgang (rechts oder links), der einen vollständigen Schutz gegen Wasserspritzer bietet (Schutzart IP 65 gemäß Tabelle IEC 529

MOSTRINA

Alluminio laccato bianco. Alloggiata nell'apposita sede posteriore esterna quindi non a contatto diretto con il fluido. Può essere sfilata prima del montaggio dalla parte con l'invito per tracciare linee di livello o diciture.

PLATE

White lacquered aluminium. Located in the corresponding external rear housing, avoiding any direct contact with the liquid. Before installation, it can be removed from the side featuring the mark to trace contours or inscriptions.

EINFASSUNG

Weiß lackiertes Aluminium. Da in einem entsprechenden externen Sitz an der Rückseite angeordnet, kommt es zu keinem direkten Kontakt mit der Flüssigkeit. Kann vor der Montage von der Laschenseite her abgezogen werden, um die Füllstandmarkierungslinien oder Beschriftungen anbringen zu können.

ESECUZIONI STANDARD

-G_L4A: con contatto elettrico normalmente aperto.
-G_L4B: con contatto elettrico normalmente chiuso.

STANDARD OPERATIONS

-G_L4A: with normally open electric contact.
-G_L4B: with normally closed electric contact.

STANDARD-AUSFÜHRUNGEN

-G_L4A: mit Schließerkontakt.
-G_L4B: mit Öffnerkontakt.

TEMPERATURA MASSIMA DI ESERCIZIO IN CONTINUO

90°C (funzionamento con olio).

CONTINUOUS MAXIMUM OPERATING TEMPERATURE

90°C (operation with oil).

MAXIMALE TEMPERATUR IM DAUERBETRIEB

90 °C (bei Betrieb mit Öl).

CARATTERISTICHE E PRESTAZIONI

L'indicatore di livello a colonna oltre al controllo visivo fornisce un segnale elettrico al raggiungimento del valore minimo del livello del fluido. Saldatura ad ultrasuoni che assicura una perfetta tenuta. Massima visibilità del livello del fluido anche da posizioni laterali. Visiera lenticolare per una maggiore visibilità del livello.

FEATURES AND PERFORMANCE

Besides visual check, the pillar level gauge provides an electrical signal once the minimum liquid level is reached. Ultrasonic sealing ensures perfect tightness. Maximum visibility of liquid level even from the sides. Magnifying lens allowing greater level visibility.

EIGENSCHAFTEN UND LEISTUNGEN

Die Säulen-Füllstandanzeige liefert zusätzlich zur Sichtkontrolle ein elektrisches Signal bei Erreichen des Mindestwerts des Flüssigkeitsstands. Ultraschall-Schweißung, die eine perfekte Dichtigkeit gewährleistet. Besonders gut, auch aus seitlichen Positionen, ersichtlicher Flüssigkeitsstand. Linsenblende für eine bessere Sicht des Füllstands.

DATI TECNICI

In prove di laboratorio effettuate con olio minerale tipo CB68 (secondo ISO 3498), a 23°C per un tempo relativamente limitato, la saldatura ha resistito fino a 13 bar.

TECHNICAL DATA

During laboratory tests performed with CB68 mineral oil (according to ISO 3498), at 23°C in a relatively short period, sealing resisted up to 13 bar.

TECHNISCHE DATEN

In mit Mineralöl vom Typ CB68 durchgeführten Labortests (nach ISO 3498) bei 23 °C und über eine relativ begrenzte Zeit hinweg, hielt die Schweißnaht bis 13 bar.

FUNZIONAMENTO DEL SENSORE ELETTRICO DI LIVELLO MIN

-G_L4A: il circuito elettrico si chiude al raggiungimento del livello di minimo.
-G_L4B: il circuito elettrico si apre al raggiungimento del livello di minimo.

MIN LEVEL ELECTRIC SENSOR OPERATION

-G_L4A: the electric circuit closes once the minimum level is reached.
-G_L4B: the electric circuit opens once the minimum level is reached.

FUNKTION DES ELEKTRISCHEN MINDESTFÜLLSTANDSENSORS

-G_L4A: der Stromkreis schließt bei Erreichen des Mindestfüllstands.
-G_L4B: der Stromkreis öffnet bei Erreichen des Mindestfüllstands.

TECHNICAL DATASHEET

Caratteristiche elettriche	<i>Electric features</i>	Eigenschaften des elektrischen Teils				
Alimentazione	<i>Power supply</i>	Versorgung	AC/DC			
Contatti elettrici	<i>Electric contacts</i>	Elektrische Kontakte	NO NC	normalmente aperto normalmente chiuso	<i>Normally open</i> <i>Normally closed</i>	Schließer Öffner
Tensione max.	<i>Max. voltage</i>	Max. Spannung	NO: 150 Vac, 100 Vdc NC: 150Vac, 150 Vdc			
Intensità max. di corrente commutabile	<i>Max. intensity of switching current</i>	Max. schaltbare Stromstärke	1 A			
Intensità max. di corrente sopportabile	<i>Max. intensity of carrying current</i>	Max. verträgliche Stromstärke	NO: 1A NC: 2A			
Max. potenza commutabile	<i>Max. switching power</i>	Max. schaltbare Leistung	NO: 10 Va NC: 20 Va			
Pressacavo	<i>Cable gland</i>	Kabelverschraubung	Pg 7	per cavi in guaina Ø 6 o 7mm	<i>For wires in sheath Ø 6 or 7 mm</i>	Für Kabel mit Ummantelung Ø6 oder 7 mm
Sezione conduttori	<i>Wire cross-section</i>	Leiterquerschnitt	Max. 1.5 mm ²			Max. 1.5 mm ²
NOTA	<i>NOTE</i>	HINWEIS		Evitare l'utilizzo di questo indicatore in prossimità di campi magnetici	<i>Avoid using this indicator close to magnetic fields</i>	Diese Anzeige sollte nicht in der Nähe von Magnetfeldern verwendet werden

Collegamenti elettrici standard:

Standard electrical connections:

Elektrische Standard-Verbindungen:

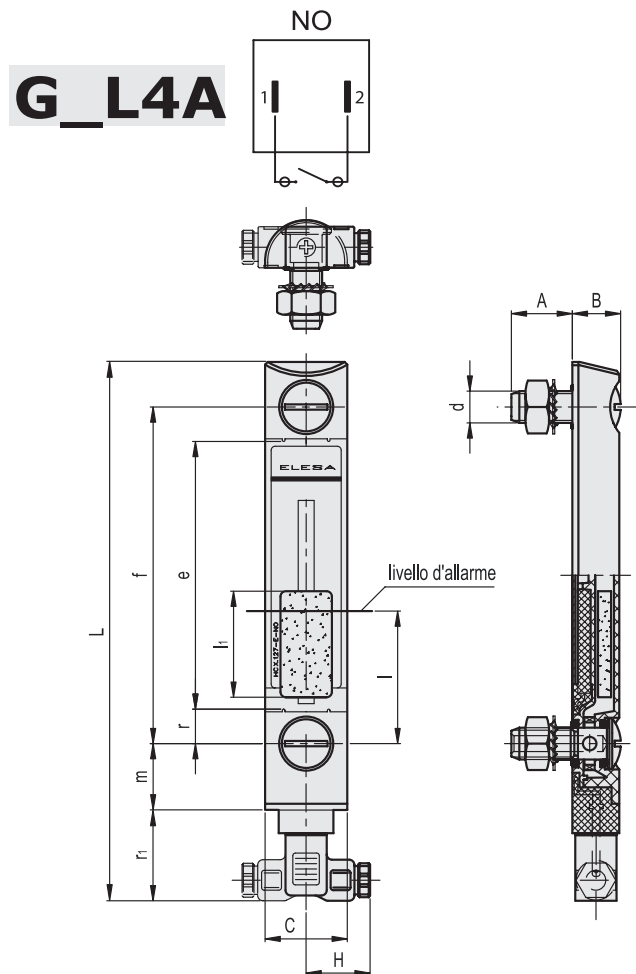

Code Designation	Code ORDER	f	d	A	B	C	H	L	e	l	l1	m	r	r1	C# [N m]	Kg
G_L4A	4411270001	127	M12	23	20	32	26	202	101	50	40	25	13	32.5	12	0.15 0

TECHNICAL DATASHEET



G_L5D

Livellostato a galleggiante

Float level switch

Schwimmerfüllstandanzeige

DESCRIZIONE

Sensore per il rilievo a distanza del livello olio con contatti reedposti all'interno del tubo scorrevole, azionati dal campomagnetico esercitato dai magneti contenuti nel galleggiante che si muove lungo il tubo stesso.

DESCRIPTION

Sensor allowing oil level remote detection with reed contacts located inside the sliding tube. They are enabled by the magnetic field created by the magnets contained in the float moving along the tube itself.

BESCHREIBUNG

Sensor zur Fernerfassung des Ölpegels mit Reed-Kontakten, die im Gleitrohr angeordnet sind und vom Magnetfeld betätigt werden, das von den im Schwimmer enthaltenen Magneten erzeugt wird. Dieser Schwimmer bewegt sich am Rohr entlang.

CARATTERISTICHE GENERALI

- Ottone–Spansil–asta inox
- N° 1 punti di intervento
- Lunghezza 150 mm
- Pressione di lavoro fino a 20 Bar
- temperatura di lavoro standard fino a 100°C
- temperatura ambiente: -40/+40°C =T6, -40/+60°C =T5
- Grado di protezione minimo IP67

GENERAL FEATURES

- Brass–Spansil–stainless bar
- No. 1 operating points
- Length 150 mm
- Operating pressure up to 20 Bar
- standard working temperature up to 100°C
- ambient temperature: -40/+40°C =T6, -40/+60°C =T5
- IP67 minimum protection level

ALLGEMEINE EIGENSCHAFTEN

- Messing–Spansil–Stab aus Edelstahl
- 1 Eingriffspunkt
- Länge 150 mm
- Arbeitsdruck bis 20 bar
- Standard-Arbeitstemperatur bis 100 °C
- Umgebungstemperatur: -40/+40 °C =T6, -40/+60 °C =T5
- Min. Schutzart IP67

OMOLOGATI IN CONFORMITA'ALLADIRETTIVAATEX2014/34 /UE

Questi strumenti, in esecuzione antideflagrante certificata CESIATEX Ext.1 II 1/2G Exd IICT6/T5, permettono il controllo del livello di liquidi o carburante in serbatoi, sia interrati che all'aperto, installati in area classificata dove vengono trattati prodotti infiammabili.

APPROVED IN COMPLIANCE WITH 2014/34/EU ATEX DIRECTIVE

These explosion-proof tools (CESIATEX Ext.1 II 1/2G Exd IICT6/T5 certified) allow liquid or fuel level check in both underground and open-air tanks installed in a classified area where flammable products are treated.

IN ÜBEREINSTIMMUNG MIT DER RICHTLINIE ATEX 2014/34/EU ZUGELASSEN

Diese Instrumente in explosions-sicherer, gemäß CESIATEX Ext.1 II 1 / 2G Exd IICT6 / T5 zertifizierter Ausführung, ermöglichen die Kontrolle des Füllstands von Flüssigkeiten oder Brennstoff in sowohl unterirdisch als auch im Freien montierten Tanks, die in einem klassifizierten Bereich installiert sind, in denen brennbare Produkte gehandhabt werden.

TECHNICAL DATASHEET

DATI ELETTRICI

Le ampole reed utilizzate nei livellostati sono ermeticamente sigillate, ad attuazione magnetica e con una affidabilità di milioni di cicli. Il tipo di contatto a riposo è in scambio (SPDT). La portata dei contatti varia secondo il tipo di ampolla reed adottata. Per i dati elettrici fare riferimento alla tabella sotto riportata.

ELECTRICAL DATA

The reed tubes used in the level switches are hermetically sealed, magnetically driven and characterised by a reliability of millions of cycles. At rest, it is a changeover contact (SPDT). Contact capacity varies according to the type of reed tube adopted. For further details about electrical data, refer to the table below.

DATEN DES ELEKTRISCHEN TEILS

Die Reed-Ampullen, die in den Füllstandwächtern verwendet werden, sind hermetisch versiegelt, werden magnetisch betätigt und weisen eine Zuverlässigkeit für Millionen an Zyklen auf. Der Ruhekontakt ist ein einpoliger Wechselschalter (SPDT-Single Pole Double Throw). Die Leistungsfähigkeit der Kontakte variiert mit dem angewendeten Typ der Reed-Ampulle.

Code Designation	Code ORDER	Potenza		Tensione		Corrente	
		VA	W	AC	DC	AC	DC
G_L5D	4411500001	20	20	150	150	0.5	0.5

Collegamenti elettrici standard::

Standard electrical connections:

Elektrische Standard-Verbindungen:

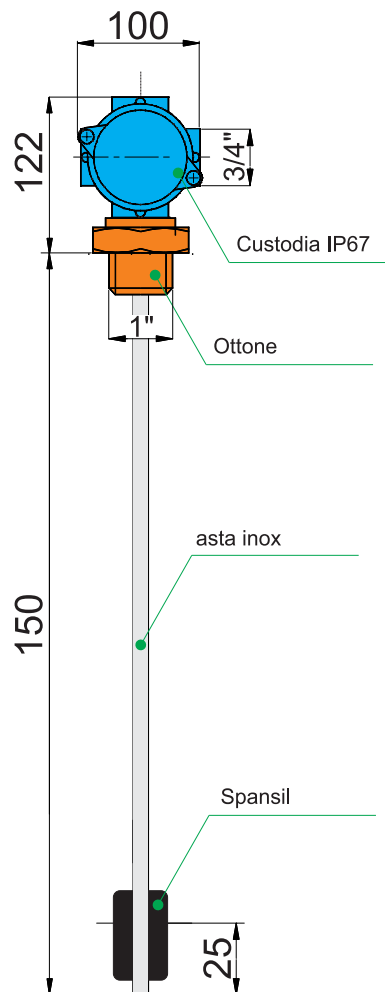
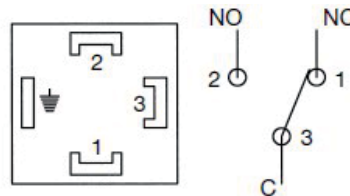



ACC7H

Accessori idraulici - HEATER

Hydraulic accessories - HEATER

Hydraulikzubehör - HEATER

7H HEATERS

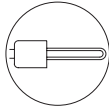

Dispositivi elettrici riscaldamento per avviamenti a basse temperature

Electrical heating devices for low temperature start-up

Elektrische Heizvorrichtungen für Starts bei niedrigen Temperaturen

Possono essere forniti i seguenti accessori e dispositivi:

Some devices can optionally be provided:

Folgende Zubehörteile und Vorrichtungen können geliefert werden:

Code Designation	Code ORDER	I	GB	DE
H ...	On request	Code HEATER	Code HEATER	Code HEATER





3.0 - Accessori idraulici

3.0 - Hydraulic accessories

3.0 - Hydraulikzubehör

ACC711	Accessori idraulici - TEMPERATURE SENSOR	Hydraulic accessories - TEMPERATURE SENSOR	Hydraulikzubehör - TEMPERATURE SENSOR
---------------	---	---	--

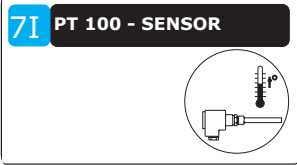

Per controllare la temperatura bagno olio. Il Pt100 può attivare un segnale d'allarme quando la temperatura dell'olio è superiore al limite specificato

To control the oil bath temperature. The Pt100 can trigger an alarm signal when the oil temperature is higher than a specified limit

Für die Kontrolle der Ölsumpftemperatur. Der Pt100 kann ein Alarmsignal auslösen, wenn die Öltemperatur über den vorgegebenen Grenzwert ansteigt

Possono essere forniti i seguenti accessori e dispositivi:

Some devices can optionally be provided:

Folgende Zubehörteile und Vorrichtungen können geliefert werden:

Code Designation	Code ORDER	I	GB	DE
I TPT1A	5031000013	= Sonda PT100 - Type1A		
I TPT2A	5031000042	= Sonda PT100 - Type2A		



TECHNICAL DATASHEET

I_TPT1A



BU

SENSORE DI TEMPERATURA

TEMPERATURE SENSOR

TEMPERATURENSOR

DESCRIZIONE

Sensore per il rilievo a distanza della temperatura.
La sonda di temperatura è realizzata con le seguenti caratteristiche.

DESCRIPTION

Sensor allowing temperature remote detection.
The temperature probe is manufactured with the following features.

BESCHREIBUNG

Sensor für die Fernfassung der Temperatur.
Die Temperatursonde verfügt über die folgenden Eigenschaften.

Caratteristiche costruttive generali

General manufacturing features

Allgemeine Konstruktionsmerkmale

- filo di platino con 100 Ω a 0 °C secondo EN 60751
- precisione classe A secondo EN 60751;
- campo di temperatura di funzionamento -40 °C + 200 °C;
- collegamento a tre fili secondo IEC 751
- sonda di acciaio inossidabile AISI 316; diametro 8 mm;
- Testa di connessione tipo DIN B
- grado di protezione IP66;
- entrata cavi G 1/2".

- platinum wire with 100 Ω at 0 °C according to EN 60751
- class A accuracy according to EN 60751;
- operating temperature range -40 °C + 200 °C;
- 3-wire connection according to IEC 751
- AISI 316 stainless steel probe; diameter 8 mm;
- terminal box DIN B;
- IP66 protection level;
- G 1/2" cable entry.

- Platindraht mit 100 Ω bei 0°C gemäß EN 60751
- Genauigkeitsklasse A gemäß EN 60751;
- Betriebstemperaturbereich -40 °C + 200 °C;
- 3-Draht-Verbindung gemäß IEC 751
- Sonde aus rostfreiem Stahl AISI 316; Durchmesser 8 mm;
- Klemmenkasten DIN B;
- Schutzart IP66;
- Kabeleingang G 1/2".

Per il collegamento del sensore al relativo dispositivo di controllo utilizzare cavo schermato di sezione 1,5 mm² posato separato dai cavi di potenza.

To connect the sensor to the corresponding control device, use a shielded cable having a section of 1.5 sq.mm, separated from power cables.

Für die Herstellung der Verbindung des Sensors an die entsprechende Kontrollvorrichtung ist ein abgeschirmtes Kabel mit einem Querschnitt von 1,5 mm² zu verwenden, das von den Leistungskabeln getrennt zu verlegen ist.

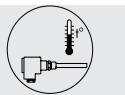

TECHNICAL DATASHEET

Collegamenti elettrici standard::

Standard electrical connections:

Elektrische Standard-Verbindungen:

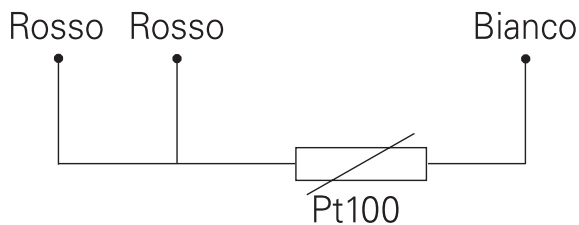

Dimensioni

Dimensions

Abmessungen

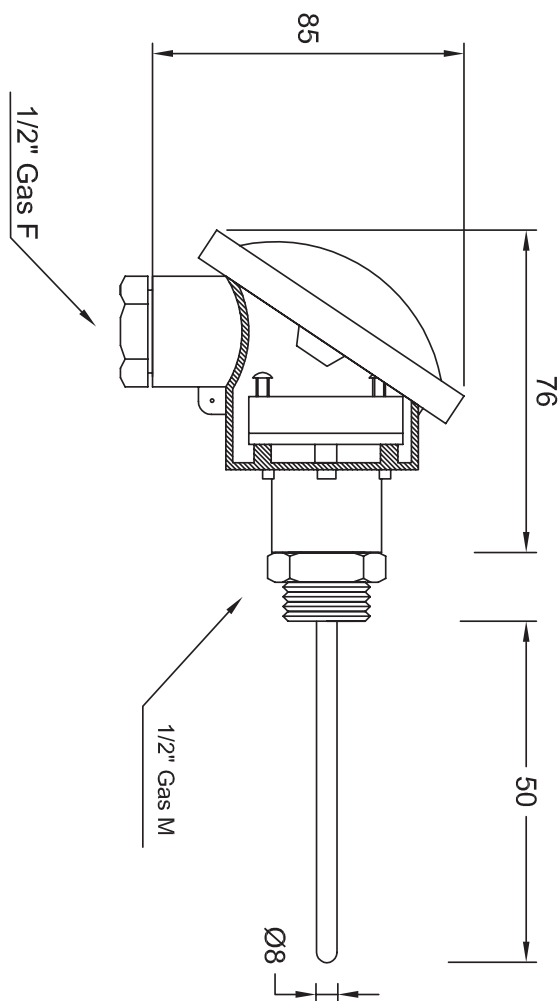



TECHNICAL DATASHEET

I_TPT2A

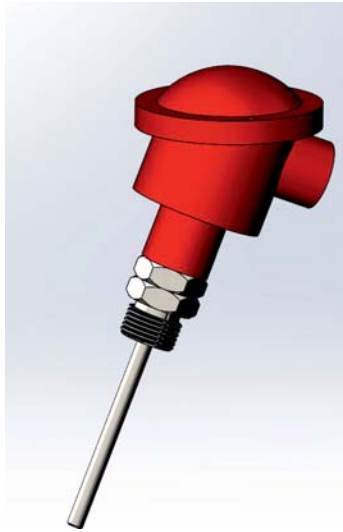

SENSORE DI TEMPERATURA

TEMPERATURE SENSOR

TEMPERATURENSOR

DESCRIZIONE

Sensore per il rilievo a distanza della temperatura.
La sonda di temperatura è realizzata con le seguenti caratteristiche.

DESCRIPTION

Sensor allowing temperature remote detection. The temperature probe is manufactured with the following features.

BESCHREIBUNG

Sensor für die Fernfassung der Temperatur. Die Temperatursonde verfügt über die folgenden Eigenschaften.

Caratteristiche costruttive generali

- filo di platino con 100 Ω a 0 °C secondo EN 60751
- Singolo elemento a 4 fili
- Trasmettitore di temperatura programmabile linearizzato 4+20 mA con protocollo HART.
- Scala -10+200 °C (altro da comunicare)
- Uscita 4+20 mA
- Alimentazione 10+36 VDC (tecnica a 2 fili)
- Precisione classe A IEC 751.
- Gambo inox \varnothing 6 mm
- Lunghezza 100 mm
- Attacco inox scorrevole filettato 1/2" Gas M cilindrico
- Testa di connessione tipo DIN B
- Esecuzione ATEX EEx-ia per applicazione in ambienti pericolosi
- Protezione IP 66

- Certificato di taratura con rif. ACCREDIA su n°03 punti

Per il collegamento del sensore al relativo dispositivo di controllo utilizzare cavo schermato di sezione 1,5 mm² posato separato dai cavi di potenza.

General manufacturing features

- *platinum wire with 100 Ω at 0 °C according to EN 60751*
- *4-wire individual element*
- *4+20 mA linearised programmable temperature transmitter with HART protocol. -Scale -10+200 °C (other to be communicated)*
- *4+20 mA output*
- *10+36 VDC power supply (2-wire method)*
- *IEC 751 class A accuracy.*
- *Stainless stem \varnothing 6 mm*
- *Length 100 mm*
- *Cylindrical Gas M 1/2" threaded sliding stainless connection*
- *DIN B connection head*
- *ATEX EEx-ia operation for hazardous environment application*
- *IP 66 protection*

- Calibration certificate with ACCREDIA ref. on no. 03 points.

To connect the sensor to the corresponding control device, use a shielded cable having a section of 1.5 sq.mm, separated from power cables.

Allgemeine Konstruktionsmerkmale

- Platindraht mit 100 Ω bei 0°C gemäß EN 60751
- Einzelnes Element mit 4 Drähten
- Programmierbarer, linearisierter Temperaturgeber 4+20 mA mit HART-Protokoll.
- Skala -10+200 °C (weitere sind mitzuteilen)
- Ausgang 4+20 mA
- Versorgung 10+36 VDC (2-Draht-Technik)
- Genauigkeitsklasse A IEC 751.
- Schaft rostfreier Stahl \varnothing 6 mm
- Länge 100 mm
- Verschiebbarer Anschluss aus rostfreiem Stahl mit Gewinde 1/2" Gas M zylindrisch
- Anschlusskopf, Typ DIN B
- Ausführung ATEX EEx-ia für die Anwendung in gefährlichen Umgebungen
- Schutzart IP 66

- Eichzertifikat mit Bez. ACCREDIA an 03 Punkten

Für die Herstellung der Verbindung des Sensors an die entsprechende Kontrollvorrichtung ist ein abgeschirmtes Kabel mit einem Querschnitt von 1,5 mm² zu verwenden, das von den Leistungskabeln getrennt zu verlegen ist.

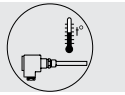

TECHNICAL DATASHEET

Dimensioni

Dimensions

Abmessungen

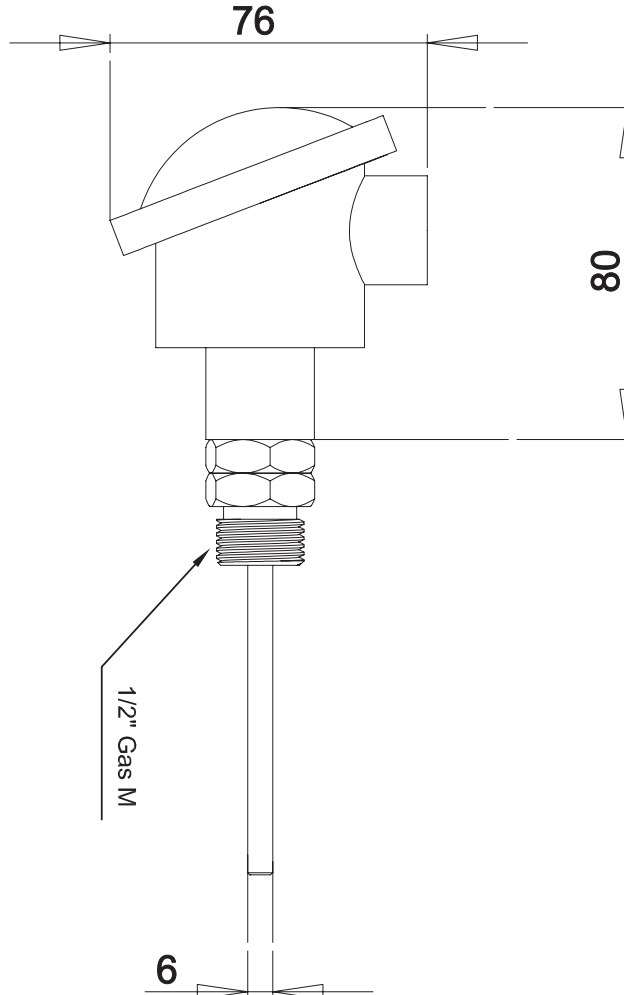

Trasmettitore a due fili con protocollo HART

2-wire transmitter with HART protocol

2-Draht-Geber mit HART-Protokoll



- Ingressi RTD, TC, Ohm, o mV
- Livello elevatissimo di precisione di misurazione
- Protocollo HART 5
- Isolamento galvanico
- Per supporto testa sensore DIN forma B

- RTD, TC, Ohm, or mV input
- Extremely high measurement accuracy
- HART 5 protocol
- Galvanic isolation
- For DIN form B sensor head mounting

- Eingänge RTD, TC, Ohm oder mV
- Höchste Messgenauigkeit
- Protokoll HART 5
- Galvanisch getrennt
- Für Abstützung des Sensorkopfs DIN Forma B



3.0 - Accessori idraulici

3.0 - Hydraulic accessories

3.0 - Hydraulikzubehör

TECHNICAL DATASHEET

Applicazione

-Misurazione temperatura linearizzata con sensore Pt100...Pt1000,Ni100...Ni1000, o TC.
 - Differenza o media di misurazione temperatura di 2 resistenze o sensori TC.
 - Conversione di variazione resistenza lineare a segnale di corrente analogico standard, per esempio da valvole o sensori di livello ohmici.
 - Amplificazione di segnale mV bipolare a un segnale di corrente standard 4...20 mA.
 -Collegamento di fino a 15 trasmettitori a un segnale digitale a due fili con comunicazione HART.

Application

*-Linearized temperature measurement with Pt100...Pt1000,Ni100...Ni1000, or TC sensor.
 -Difference or average temperature measurement of 2resistance or TC sensors.
 -Conversion of linear resistance variation to a standard analogcurrent signal, for instance from valves or Ohmic levelsensors.
 -Amplification of a bipolar mV signal to a standard 4...20 mAcurrent signal.
 -Connection of up to 15 transmitters to a digital 2-wire signalwith HART communication.*

Anwendung

-Linearisierte Temperaturmessung mit Sensor Pt100...Pt1000, Ni100...Ni1000 oder TC.
 - Differenz oder Mittelwert der Temperaturmessung von 2 Widerständen oder TC-Sensoren.
 - Umwandlung der linearen Widerstandsvariation in analoges Standard-Stromsignal, beispielsweise von Ventilen oder ohmschen Füllstandsensoren.
 - Verstärkung eines zweipoligen mV-Signals in ein Standard-Stromsignal 4...20 mA.
 - Anschlussmöglichkeit von bis zu 15 Gebern an ein digitales Signal mit zwei Drähten und HART-Kommunikation.

Caratteristiche tecniche

- In pochi secondi l'utente può programmare PR5335D affinché misuri le temperature in tutte le gamme definite dalle norme.
 -Gli ingressi RTD e di resistenza hanno una compensazione di cavo per il collegamento a 2, 3 e 4 fili.
 -Il 5335D è stato disegnato in conformità a severi requisiti di sicurezza e quindi è adatto per applicazione in installazioni SIL 2.
 - Controllo continuo di dati vitali salvati per motivi di sicurezza.
 -Rilevamento errore sensore secondo le linee guida in NAMURNE89.

Technical characteristics

*-Within a few seconds the user can program PR5335D tomeasure temperatures within all ranges defined by the norms.
 -The RTD and resistance inputs have cable compensation for2-, 3- and 4-wire connection.
 -The 5335D has been designed according to strict safetyrequirements and is therefore suitable for application in SIL 2installations.
 -Continuous check of vital stored data for safety reasons.
 -Sensor error detection according to the guidelines in NAMURNE89.*

Technische Eigenschaften

- Der PR5335D kann in nur wenigen Minuten vom Benutzer programmiert werden, um die Temperaturen in allen von den Normen vorgegebenen Bereichen zu messen.
 - Die Eingänge von RTD und des Widerstands haben einen Kabelabgleich für die 2-, 3- und 4-Drahtverbindung.
 - Der 5335D wurde in Übereinstimmung mit den strengsten Sicherheitsanforderungen entwickelt und eignet sich daher für den Einsatz in SIL 2 Installationen.
 - Dauerkontrolle der lebenswichtigen, aus Sicherheitsgründen gespeicherten Daten.
 - Erfassung eines Sensorfehlers laut Anweisungen in NAMURNE89.

Collegamenti elettrici standard::

Standard electrical connections:

Elektrische Standard-Verbindungen:

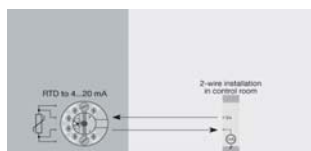

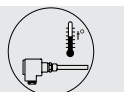

TECHNICAL DATASHEET

Condizioni ambientali	Environmental Conditions	Umgebungsbedingungen	
Gamma specifiche	Specifications range	Bereichsspezifikationen	-40°C to +85°C
Temperatura di calibrazione	Calibration temperature	Kalibriertemperatur	20...28°C
Umidità relativa	Relative humidity	Relative Feuchtigkeit	< 95% RH (non-cond.)
Grado di protezione (cust./morsettiere)	Protection degree (encl./terminal)	Schutzart (Gehäuse/Klemmenkasten)	IP68 / IP00
Specifiche meccaniche	Mechanical specifications	Mechanische Spezifikationen	
Dimensioni	Dimensions	Abmessungen	ø 44 x 20.2 mm
Peso approssimativo	Weight approx.	Gewicht, ungefähr	50 g
Dimens.filo	Wire size	Maße Draht	1 x 1.5 mm ² stranded wire
Coppia vite morsetto	Screw terminal torque	Anzugsmoment Klemmschraube	0.4 Nm
Vibrazione	Vibration	Schwingung	IEC 60068-2-6 : 2007
Vibrazione: 2...25 Hz	Vibration: 2...25 Hz	Schwingung: 2...25 Hz	± 1.6 mm
Vibrazione: 25...100 Hz	Vibration: 25...100 Hz	Schwingung: 25...100 Hz	± 4 g
Specifiche comuni	Common specifications	Allgemeine Daten	
Alimentazione	Supply voltage	Versorgung	8.0...30 VDC
Tensione isolamento, test/funzionamento	Isolation voltage, test /working	Isolierspannung, Test/Betrieb	1.5 kVAC / 50 VAC
Tempo risposta (programmabile)	Response time (programmable)	Ansprechzeit (programmierbar)	1...60 s
Tempo riscaldamento	Warm-up time	Heizdauer	30 s
Programmazione	Programming	Programmierung	Loop Link & HART
Rapporto segnale / rumore	Signal / noise ratio	Verhältnis Signal / Lärm	Min. 60 dB
Precisione	Accuracy	Genauigkeit	Better than 0.05% of selected range
Dinamica di segnale, ingresso	Signal dynamics, input	Signaldynamik, Eingang	22 bit
Dinamica di segnale, uscita	Signal dynamics, output	Signaldynamik, Ausgang	16 bit
Effetto del cambio di alimentazione	Effect of supply voltage change	Reaktion des Versorgungswechsels	< 0.005% of span / VDC
influenza immunità EMC	EMC immunity influence	Einfluss der Störfestigkeit EMV	< ± 0.1% of span
Immunità EMC estesa: NAMURNE 21, criterio A, scarica	Extended EMC immunity: NAMUR NE 21, A criterion, burst	Erweiterte Störfestigkeit EMV: NAMURNE 21, Kriterium A, Entladung	< ± 1% of span
Specifiche ingresso	Input specifications	Eingangsdaten	
Offset max.	Max. offset	Max. Offset	50% of selected max. value
Tipo RTD	RTD type	Typ RTD	Pt100, Ni100, lin. R
Resistenza cavo per filo (max.)	Cable resistance per wire (max.)	Kabelwiderstand pro Draht (max.)	5 Ω (up to 50 Ω per wire is possible with reduced measurement accuracy)
Corrente sensore	Sensor current	Sensorstrom	Nom. 0.2 mA
Effetto della resistenza del cavo del sensore (3-/4-fili)	Effect of sensor cable resistance (3-/4-wire)	Reaktion des Widerstands des Sensorkabels (3-/4-Drähte)	< 0.002 Ω / Ω
Rilevamento errore sensore	Sensor error detection	Erfassung des Sensorfehlers	Yes
Ingresso tensione	Voltage input	Spannungseingang	
Gamma misurazione	Measurement range	Messbereich	-800...+800 mV
Gamma min. misurazione (campo)	Min. measurement range (span)	Min. Messbereich (Feld)	2.5 mV
Resistenza ingresso	Input resistance	Eingangswiderstand	10 MΩ



TECHNICAL DATASHEET

Specifiche uscita	Output specifications		
Gamma segnale	Signal range	Output specifications	4...20 mA
Gamma segnale min.	Min. signal range	Ausgangsdaten	16 mA
Carico (@ uscita corrente)	Load (@ current output)	Signalbereich	$\leq (V_{supply} - 8) / 0.023 [\Omega]$
Stabilità carico	Load stability	Min. Signalbereich	$\leq 0.01\%$ of span / 100 Ω
Indicazione errore sensore.	Sensor error indication.	Last (@ Stromausgang)	Programmable 3.5...23 mA
NAMUR NE 43 Upscale/Downscale	NAMUR NE 43 Upscale/Downscale	Laststabilität	Programmable 3.5; 23 mA
*del campo	*of span	*des Felds	= of the presently selected range
Requisiti rispettati per le autorità	Observed authority requirements	Für die Behörden eingehaltene Anforderungen	
EMC	EMC	EMC	2014/30/EU
Approvazioni	Approvals	Bescheinigungen	
ATEX 2014/34/EU	ATEX 2014/34/EU	ATEX 2014/34/EU	KEMA 03ATEX1537
IECEX	IECEX	IECEX	KEM 10.0083X
FM	FM	FM	2D5A7
CSA	CSA	CSA	1125003
INMETRO	INMETRO	INMETRO	NCC 12.0844 X
EAC	EAC	EAC	TR-CU 020/2011
EAC Ex TR-CU 012/2011	EAC Ex TR-CU 012/2011	EAC Ex TR-CU 012/2011	RU C-DK.GB08.V.00410
DNV Marine	DNV Marine	DNV Marine	Stand. f. Certific. No. 2.4
SIL	SIL	SIL	Hardware assessed for use in SIL applications



ACC7M2	Accessori idraulici - PRESSURE SWITCH	Hydraulic accessories - PRESSURE SWITCH	Hydraulikzubehör - PRESSURE SWITCH
---------------	--	--	---

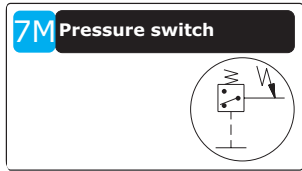

Per controllare la pressione dell'olio, può essere fornito un pressostato / trasmettitore di pressione. Possono attivare un segnale d'allarme quando la pressione scende al di sotto di un limite specifico.

To control the oil pressure, a pressure switch transmitter can be provided. They can trigger an alarm signal when the oil pressure falls beneath a specified limit.

Für die Öldruckkontrolle kann ein Druckschalter / Druckgeber geliefert werden. Diese können ein Alarmsignal auslösen, wenn der Druck unter den vorgegebenen Grenzwert sinkt.

Possono essere forniti i seguenti accessori e dispositivi:

Some devices can optionally be provided:

Folgende Zubehörteile und Vorrichtungen können geliefert werden:

Code Designation	Code ORDER	I	GB	DE
M_PSW1A	4200200001	= Pressostato - Type1A	= Pressure switch - Type1A	= Druckschalter - Type1A

TECHNICAL DATASHEET

M_PSW1A



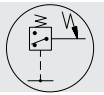

TECHNICAL DATASHEET

PRESSOSTATO DI MINIMA

MINIMUM PRESSURE SWITCH

MINDESTDRUCKWÄCHTER

Il pressostato di minima controlla la pressione dell'olio e commuta due contatti in scambio quando tale pressione diminuisce al di sotto del valore di minima preimpostato. Il valore di minima è da reimpostare a cura del Cliente ed è visualizzato da un indice che scorre sulla destra e si ottiene agendo sulla vite di regolazione posta sul frontale del pressostato.

The low pressure switch controls the oil pressure and commutates two exchange contacts when the pressure decreases under the minimum value. The minimum value to be preset by the Customer is shown by an index on the right and it is achieved by acting on the adjustment screw on the front of the pressure switch.

Der Mindestdruckwächter überwacht den Öldruck und schaltet zwei Wechselkontakte, wenn dieser Druck unter den untersten voreingestellten Wert sinkt. Der Mindestwert muss vom Kunden eingegeben werden und wird von einer rechts stehenden Anzeige angegeben. Die Einstellung erfolgt über die Einstellschraube, die vorne am Druckwächter angeordnet ist.

Dati tecnici

Tensione massima 48 Vca/cc
 Intensità di corrente 0.5(0.2) A
 Campo di temperatura -5° +60°C
 Contatti:NO
 Protezione con Coperchio in classe di protezione IP 65.

Technical data

Max voltage 48V ac/dc
 Current intensity 0.5(0.2) A
 Temperature range -5°/+60°
 Contacts: NO
 Protection with cover following IP65 protection class

Technische Daten

Max Spannung 48V AC / DC
 Stromstärke 0.5(0.2) A
 Temperaturbereich -5°/+60°
 Kontakte: NO
 Schutzeinrichtung mit Deckel entsprechend Schutzart IP65

Designation	Code Part	ø D	Regulation range bar	Contact type	Max static pressure bar	Fixed Hysteresis at 25°C bar	Tolerance at 25°C bar	Execution	Set-point adjustment bar
M_PSW1A	4200200001	G 1/8 taper	0.15 - 2	NO	300	0.15	±0.2	Diaphragm	falling at 0.3

M_PSW1A

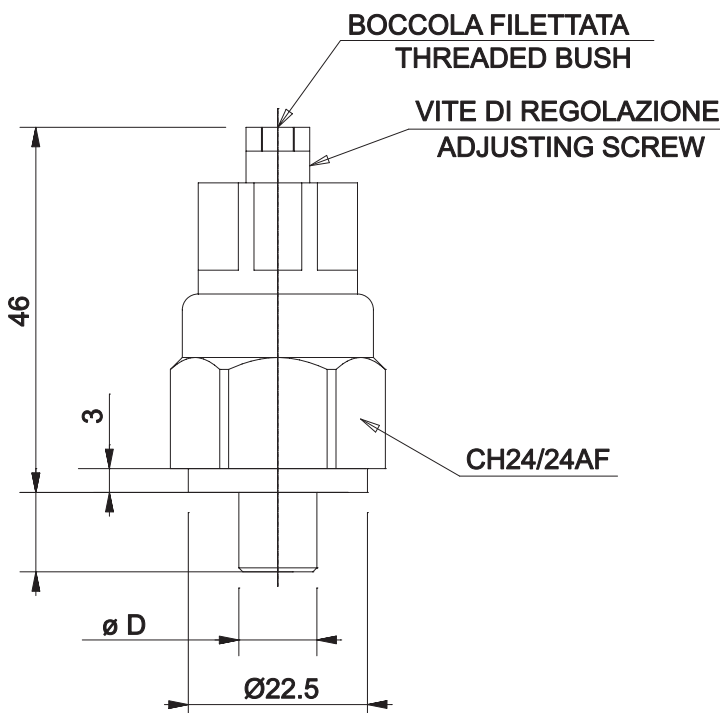
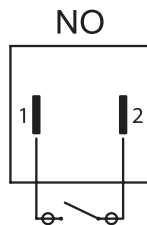

CAPPUCIO DI PROTEZIONE / PROTECTION CAP

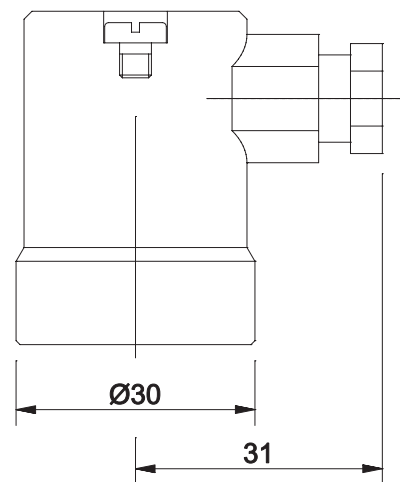

4250650001



4.0 - Anelli di tenuta

4.0 - Seals

4.0 - Dichtringe

ACC8	ACC8 - Accessori - Tipo Tenute	ACC8 - Accessories - Seal Type	ACC8 - Zubehör - Typ von Dichtung
-------------	---	---	--

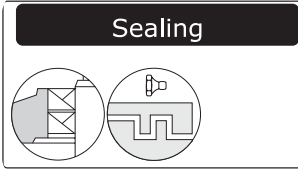

E' possibile richiedere diverse tipologie costruttive per realizzare la tenuta dinamica del riduttore.

It is possible to request various types of manufacturing to ensure the dynamic tightness of the gearbox.

Es können verschiedene Bauarten angefordert werden, um die dynamische Dichtigkeit des Getriebes zu erhalten.

Possono essere forniti i seguenti accessori e dispositivi:

Some devices can optionally be provided:

Folgende Zubehörteile und Vorrichtungen können geliefert werden:

Code Designation	Code ORDER	I	GB	DE
DW2		= Dry-Well - Type 2	= Dry-Well- Type 2	= Dichtungsstoffe- Type 2
DW2-LB2		= Doppio anello di tenuta con labbro parapolvere con tenuta a labirinto in Uscita+Dry-Well - Type 2	= Double dust lip seal with Labyrinth seal - Output Shaft+Dry-Well - Type 2	= Doppeldichtung mit Staublippe mit Labyrinth-Dichtung - Abtriebwellen-Dry-Well - Type 2
On request		= Stainless steel ring under the oil seal	= Stainless steel ring under the oil seal	= Stainless steel ring under the oil seal

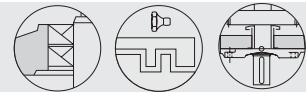

4.0 - Anelli di tenuta

4.0 - Seals

4.0 - Dichtringe

4.1 - Albero Entrata

4.1 - Input shaft

4.1 - Antriebswelle



4.2 - Albero Uscita - DW2

4.2 - Output shaft - DW2

4.2 - Abtriebswelle - DW2

Dry-Well

Dry-Well

Dichtungsstoffe

DW2 Questo dispositivo garantisce la tenuta dell'albero lento sporgente. Si rende necessario verificare/ripristinare la carica di grasso al cuscinetto inferiore dell'asse lento.

The dry-well feature prevents oil leakage at the solid output shaft.
Ple ase note that the grease charge of the output shaft lower bearing must be checked/refilled.

Diese Vorrichtung gewährleistet die Abdichtung der hervorstehenden Abtriebswelle. Hier ist eine Kontrolle/Nachfüllung der Fettfüllung des unteren Lagers der Abtriebsachse erforderlich.

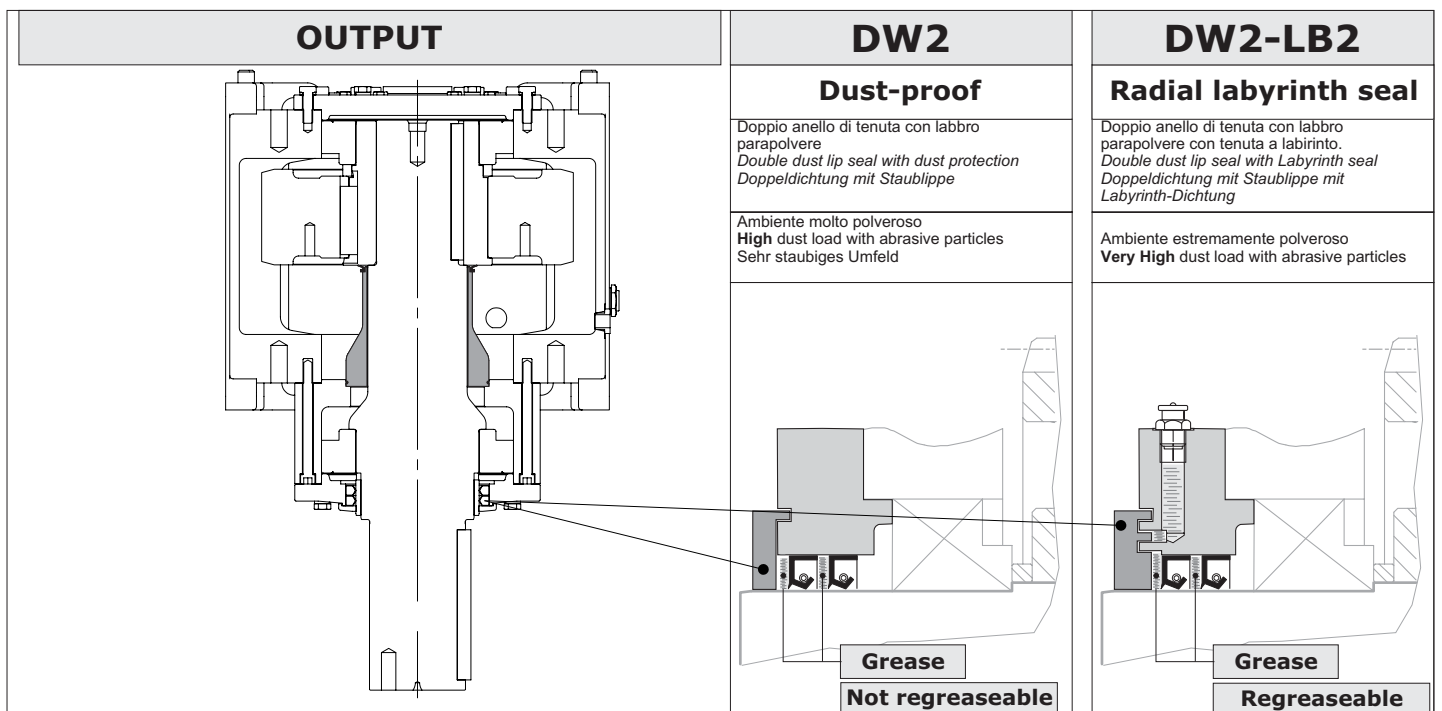



4.0 - Anelli di tenuta

4.0 - Seals

4.0 - Dichtringe

4.2 - Albero Uscita

4.2 - Output shaft

4.2 - Abtriebswelle

Stainless steel ring under the oil seal

Stainless steel ring under the oil seal

Stainless steel ring under the oil seal

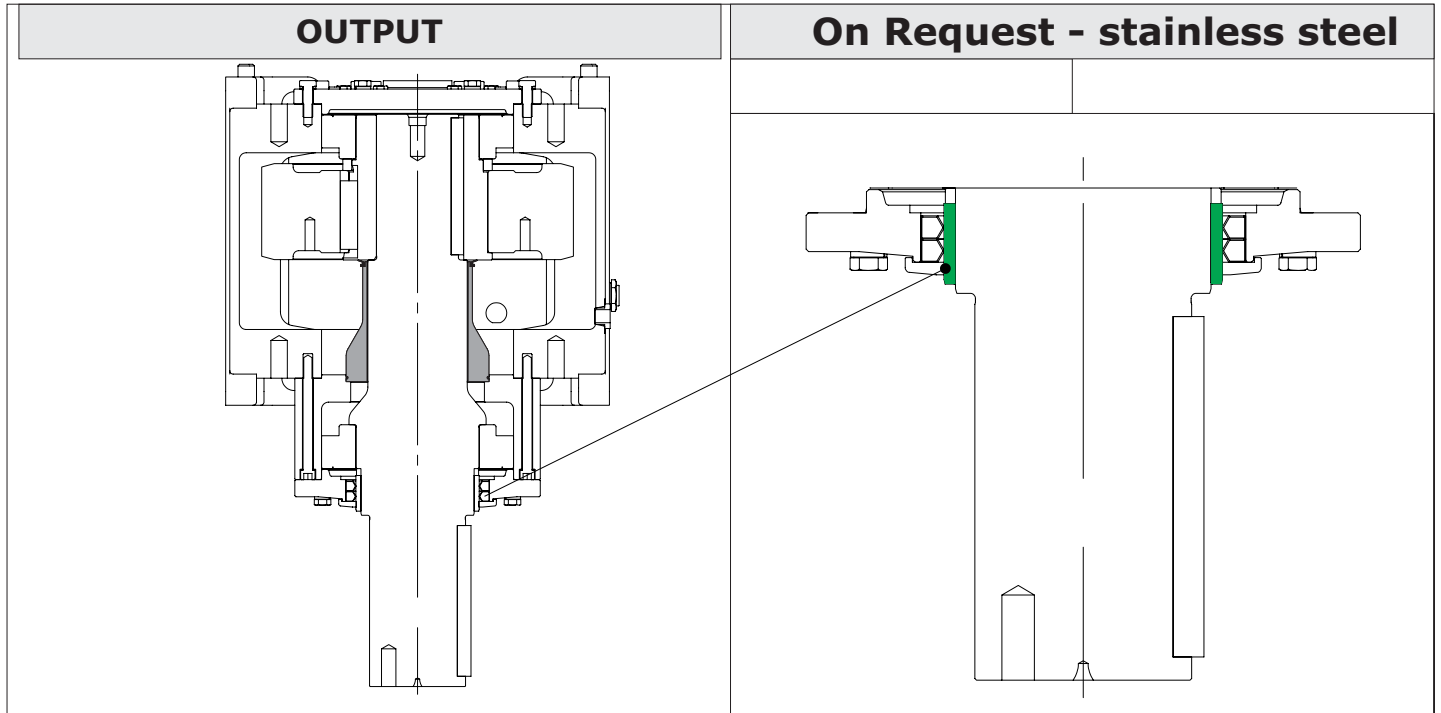



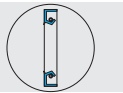

4.0 - Anelli di tenuta

4.0 - Seals

4.0 - Dichtringe

OPT	OPT - Opzioni - Materiale degli anelli di tenuta	OPT - Options - Materials of Seals	OPT - Optionen - Dichtungstoffe
-----	---	---	--

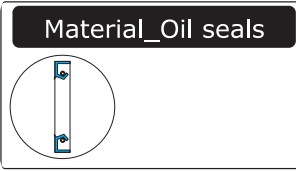

E' possibile richiedere materiali opzionali per gli anelli per la tenuta dinamica del riduttore.

It is possible to request optional material for the dynamic tightness of gearbox seal rings.

Es können Dichtringe aus optionalen Materialien für die dynamische Dichtigkeit des Getriebes angefordert werden.

Possono essere forniti i seguenti accessori e dispositivi:

Some devices can optionally be provided:

Folgende Zubehörteile und Vorrichtungen können geliefert werden:

Code Designation	Code ORDER	I	GB	DE
VT1		= Paraoli in viton in entrata	= <i>Viton oil seals at input end</i>	= Ölabdichtungen aus Viton im Antrieb
VT2		= Paraoli in viton in uscita	= <i>Viton oil seals at output end</i>	= Ölabdichtungen aus Viton im Abtrieb
VT		= Paraoli in viton in entrata ed in uscita	= <i>Viton oil seals at input and output end</i>	= Ölabdichtungen aus Viton im An- und Abtrieb
SL1		= Paraoli in silicone in entrata	= <i>Input Silicon oil seals</i>	= Eingehender Silikon-Dichtungsring
SL2		= Paraoli in silicone in uscita	= <i>Output Silicon oil seals</i>	= Ausgehender Silikon-Dichtungsring
SL		= Tenute in Silicone in Entrata - Uscita	= <i>Inpu and Output Silicon oil seals</i>	= Ein-und ausgehende Silikon-Dichtungsringe

4.0 - Anelli di tenuta

4.0 - Seals

4.0 - Dichtringe

4.1 - Applicabilità

4.1 - Application

4.1 - Applikation

	RX01 - RXV1	RX02 - RXV2 RX03 - RXV3
VT1		
VT2	A richiesta <i>On request</i> Auf Anfrage	
VT		
SL1		
SL2	A richiesta <i>On request</i> Auf Anfrage	
SL		

4.2 - Materiale degli anelli di tenuta



4.2 - Materials of Seals

4.2 - Dichtungstoffe

Serie Series Baureihe	OPT Opzioni - Materiale degli anelli di tenuta <i>Options - Materials of Seals</i> Optionen - Dichtungsstoffe	
	— (Tenute STANDARD <i>Oil Seals Standard</i> Ölabdichtungen Standard) Opzioni - Disponibile <i>Options Available</i> Optionen - verfügbar
RX	— (NBR)	VT1 - VT2 - VT - SL1- SL2 - SL

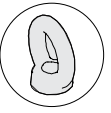

NBR1	Paraoli in NBR in entrata	<i>NBR oil seals at input end</i>	Ölabdichtungen aus NBR im Antrieb
NBR2	Paraoli in NBR in uscita	<i>NBR oil seals at output end</i>	Ölabdichtungen aus NBR im Abtrieb
NBR	Paraoli in NBR in entrata ed in uscita	<i>NBR oil seals at input and output end</i>	Ölabdichtungen aus NBR im An- und Abtrieb
VT1	Paraoli in viton in entrata	<i>Viton oil seals at input end</i>	Ölabdichtungen aus Viton im Antrieb
VT2	Paraoli in viton in uscita	<i>Viton oil seals at output end</i>	Ölabdichtungen aus Viton im Abtrieb
VT	Paraoli in viton in entrata ed in uscita	<i>Viton oil seals at input and output end</i>	Ölabdichtungen aus Viton im An- und Abtrieb
SL1	Paraoli in silicone in entrata	<i>Input Silicon oil seals</i>	Eingehender Silikon-Dichtungsring
SL2	Paraoli in silicone in uscita	<i>Output Silicon oil seals</i>	Ausgehender Silikon-Dichtungsring
SL	Paraoli in silicone in entrata ed in uscita	<i>Input and output oil seals</i>	Ein- und ausgehende Silikon-Dichtungsringe

ACC9.	ACC9. - Custom on request	ACC9. - Custom on request	ACC9. - Custom on request
<p>9B Brake flange - IEC motor</p> 	<p>Un freno personalizzato può essere fornito su richiesta nella flangia IEC del riduttore.</p>	<p><i>Custom type of brake can be supplied on request in input IEC flange of gearbox.</i></p>	<p>Auf Anfrage kann ein kundenspezifischer Bremsentyp im IEC-Eingangsfansch des Getriebes geliefert werden.</p>
<p>9. EYEBOLT</p> 	<p>Per facilitare le operazioni di trasporto e movimentazione del riduttore..</p>	<p><i>To facilitate operations for the transport and movement of the gearbox</i></p>	<p>Um den Transport und die Bewegung des Getriebes zu erleichtern.</p>
<p>9. ISPECTION</p> 	<p>Un tappo può essere fornito su richiesta per controllare il giunto..</p>	<p><i>A cap can be supplied on request to be checked the joint</i></p>	<p>Auf Anfrage kann eine Kappe geliefert werden, um die Verbindung zu überprüfen.</p>