

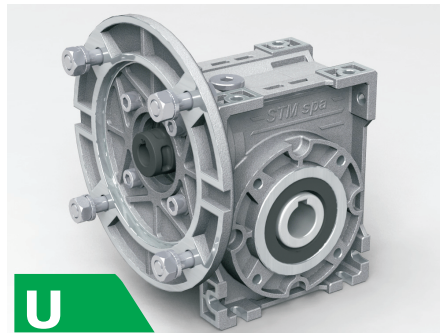

**1.0 RIDUTTORI A VITE SENZA FINE U**  
**1.0 WORM GEARBOXES U**  
**1.0 SCHNECKENGETRIEBE U**

**U**

1.1	Caratteristiche tecniche	<i>Technical characteristics</i>	Technische Eigenschaften	<b>C1</b>
1.2	Designazione	<i>Designation</i>	Bezeichnungen	<b>C3</b>
1.2	Versioni	<i>Versions</i>	Ausführungen	<b>C3</b>
1.4	Lubrificazione	<i>Lubrication</i>	Schmierung	<b>C7</b>
1.5	Carichi radiali e assiali	<i>Axial and overhung loads</i>	Radiale und Axiale Belastungen	<b>C8</b>
1.6	Prestazioni riduttori	<i>Gearboxes performances</i>	Leistungen der Getriebe	<b>C10</b>
1.7	Prestazioni motoriduttori	<i>Gearmotors performances</i>	Leistungen der Getriebemotoren	<b>C12</b>
1.8	Dimensioni	<i>Dimensions</i>	Abmessungen	<b>C18</b>
1.9	Accessori	<i>Accessories</i>	Zubehör	<b>C20</b>



**1.1 Caratteristiche tecniche**

STM presenta un nuovo riduttore di moderna concezione a forma cubica. Questa forma del riduttore permette universalità di fissaggio e modularità estrema per lo stoccaggio del prodotto finito: con l'adozione di un giunto d'accoppiamento al quale possono essere accoppiati tutti i motori Brushless e IEC si garantisce così un'ulteriore versatilità delle configurazioni possibili e l'eliminazione del fenomeno di fretting. La carcassa è disegnata in modo da ottimizzare lo smaltimento del calore e semplificare le operazioni di pulizia, anche negli ambienti più ostili.

**1.1 Technical characteristics**

STM introduces a new range of cube-shaped worm gearboxes. This execution is suitable for a wide variety of fixing possibilities and allows a better modularity of the components in stock. In fact, through an input coupling it is possible to connect all sizes IEC and brushless electric motors and enable a wide range of possible gearbox configurations as well as improving the overall quality by eliminating the fretting. The body has been designed in order to optimize the heat dissipation and to simplify the cleaning of it, even in the most difficult environmental conditions.

**1.1 Technische Eigenschaften**

STM stellt ein neues modern gestaltetes Getriebe in kubischer Form vor. Diese Getriebeform bietet universelle Befestigungsmöglichkeiten und ist äußerst anpassungsfähig bei der Lagerung des Endproduktes: durch die Verwendung einer Kupplung, an die alle bürstenlosen Motoren und IEC angeschlossen werden können, wird die Vielseitigkeit der möglichen Konfigurationen erhöht und die Beseitigung des Phänomens „Fressen“ sichergestellt. Das Gehäuse ist so konzipiert, dass die Wärmeableitung optimiert ist und die Reinigungsarbeiten vereinfacht werden, und dies auch unter schwierigsten Bedingungen.





### 1.1 Caratteristiche tecniche

#### Caratteristiche giunto STM

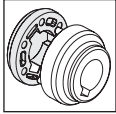

- Ingombri **Ridotti**;
- Semplicità di connessione;
- **NO** Fretting;
- **NO** Vibrazioni;
- Progettato per garantire efficienza e affidabilità con servizi gravosi in presenza di urti e con numerosi avviamenti.

### 1.1 Technical characteristics

#### STM Special features - Coupling

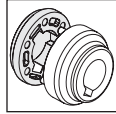

- **Reduced Sizes**
- **Simplified connections**
- **No fretting**
- **No vibrations**
- *Designed in order to warrant efficiency and reliability with heavy duty in case of bumps and frequent start-ups*

### 1.1 Technische Eigenschaften

#### Die STM Sondermerkmale - Kupplung:

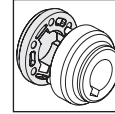

- Verringerter Platzbedarf;
- Einfacher Anschluss;
- Keine Abnutzung;
- Keine Vibrationen;
- Gewährleistet Effizienz und Zuverlässigkeit bei hoher Belastung, Stossbeeinträchtigung und zahlreichen Maschinen-Starts.

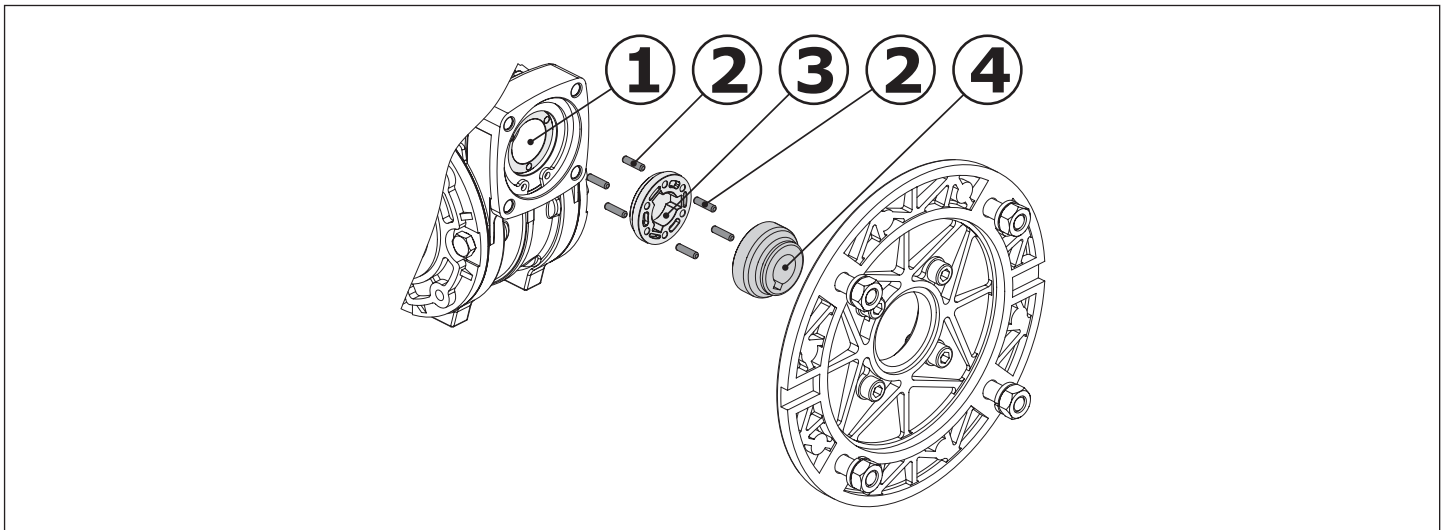

#### MATERIALE:

- 1 - Vite senza fine  
Acciaio Cementazione;
- 2 - Pioli - - Acciaio per cuscinetti
- 3 - Giunto - Tecnopolimero PA 46
- 4 - Semigiunto - Acciaio da bonifica.

#### MATERIAL:

- 1 - Worm gear – cementation steel
- 2 – Pin – bearing steel
- 3 - Coupling – techno polymer PA 46
- 4 – Coupling half - tempered steel

#### MATERIAL:

- 1 – Schneckenwelle - Einsatzstahl
- 2 – Stifte – Lagerstahl
- 3 – Kupplung – Technopolymer PA 46
- 4 – Kupplungshälfte – Stahl wärmebehandelt

#### MANUTENZIONE:

- Facilità di Montaggio motore;
- Facilità di Smontaggio

#### MAINTENANCE:

- Easy motor assembly;
- Easy disassembly.

#### WARTUNG:

- Einfacher Motoreinbau;
- Einfacher Ausbau.

#### MODULARITA':

- Possibilità di utilizzare il giunto sulle serie "RMI" - "CRMI".

#### MODULARITY:

- Possibility of coupling's using specially those of "RMI" - "CRMI" series.*

#### MODULARITÄT

- Die Kupplung kann in den Serien „RMI“ - „CRMI...G“ verwendet werden.

#### TEMPI DI CONSEGNA:

- Maggiore modularità del prodotto;
- Stock a magazzino del prodotto assemblato.

#### DELIVERY DATES

- Higher product's modularity
- Stock warehouse finished product.

#### LIEFERZEITEN:

- Größere Modularität des Produktes;
- Montiertes Produkt im Lagerbestand





**1.2 Designazione**

**1.2 Designation**

**1.2 Bezeichnung**

**04 IR- Rapporto di riduzione**

**IR - Reduction ratio**

**IR - Übersetzungsverhältnis**

(Vedi prestazioni). Tutti i valori dei rapporti sono approssimati. Per applicazioni dove necessita il valore esatto consultare il ns. servizio tecnico.

(See ratings). Ratios are approximate values. If you need exact values for a specific application, please contact our Engineering.

(Siehe "Leistungen"). Bei allen Werten der Übersetzungen handelt es sich um approximative Wertangaben. Bei Applikationen, bei denen die exakte Wertangabe erforderlich ist, muss unser Technischer Kundendienst konsultiert werden.

05 06 07	<b>UMI</b>	<b>IECT - Tipo IEC e Albero Entrata</b>	<b>IECT - IEC type and Input Shaft</b>	<b>OV - IEC Typ und Antriebswelle</b>
		<b>IV - Versione Entrata</b>	<b>IV - Input Version</b>	<b>IV - Antriebsausführung</b>
		<b>IS - Albero Entrata</b>	<b>IS - Input shaft</b>	<b>IS - Antriebswelle</b>

Possibili accoppiamenti con motori IEC - Possible couplings with IEC motors - Mögliche Verbindungen mit IEC-Motoren															
	IECT	IV	IS	ir - (Rapporto di riduzione / Reduction ratio / Übersetzungsverhältnis)											
				5	7	10	15	20	28	40	49	56	70	80	100
40	G	—	71	14/160 (B5) - 14/105 (B14) - 14/140 - 14/120 - 14/90•											
			63	11/140 (B5) - 11/90• (B14) - 11/160 - 11/120 - 11/105											
			56	9/120 (B5) - 9/160 - 9/140 - 9/105 - 9/90•											
50	G	—	80	19/120 (B14) - 19/200 (B5) - 19/160 - 19/140 - 19/105• - 19/90•											
			71	14/160 (B5) - 14/105• (B14) - 14/200 - 14/140 - 14/120 - 14/90•											
			63	11/140 (B5) - 11/90• (B14) - 11/200 - 11/160 - 11/120 - 11/105•											
63	G	—	90	24/200 (B5) - 24/140 (B14) - 24/160 - 24/120 - 24/105•											
			80	19/200 (B5) - 19/120 (B14) - 19/160 - 19/140 - 19/105•											
			71	14/160 (B5) - 14/105• (B14) - 14/200 - 14/140 - 14/120											
75	G	—	112 <sup>(1)</sup>	—	28/250 (B5) - 28/160 (B14) 28/140										
			100 <sup>(1)</sup>	—	28/250 (B5) - 28/160 (B14) 28/140										
			90	—	24/200 (B5) - 24/140 (B14) - 24/250 - 24/160 - 24/120•										
			80	—	19/200 (B5) - 19/120 (B14)• - 19/250 - 19/160 - 19/140										
90	G	—	112 <sup>(1)</sup>	—	28/250 (B5) - 28/160 (B14)										
			100 <sup>(1)</sup>	—	28/250 (B5) - 28/160 (B14)										
			90	—	24/200 (B5) - 24/140 (B14) - 24/250 - 24/160 - 24/120										
			80	—	19/200 (B5) - 19/120 (B14) - 19/250 - 19/160 - 19/140										
110	G	—	132 <sup>(1)</sup>	—	38/300 (B5) - 38/250 - 38/160 - 38/140										
			112	—	28/250 (B5) - 28/160 (B14) - 28/140 - 28/200 - 28/300										
			100	—	28/250 (B5) - 28/160 (B14) - 28/140 - 28/200 - 28/300										
			90	—	24/200 (B5) - 24/140 (B14) - 24/250 - 24/160 - 24/300										

<sup>(1)</sup>**ATTENZIONE!**  
(Vedere Paragrafo 1.12).

<sup>(1)</sup>**WARNING!**  
(Look at chapter 1.12).

<sup>(1)</sup>**ACHTUNG!**  
(s. S. 1.12).

Nella tab. sono riportate le grandezze motore accoppiabili (IEC) unitamente alle dimensioni albero/flangia motore standard

Legenda:  
11/140 (B5): combinazioni albero/flangia standard  
11/120 : combinazioni albero/flangia a richiesta

In table the possible shaft/flange dimensions IEC standard are listed.

Key:  
11/140 : standard shaft/flange combination  
11/120 : shaft/flange combinations upon request

In Tabelle sind die möglichen Welle/Flansch- Abmessungen IEC-Standard aufgelistet.

Legende:  
11/140 : Standardkombinationen Welle/Flansch  
11/120 : Sonderkombinationen Welle/Flansch



1.2 Designazione

1.2 Designation

1.2 Bezeichnung

<b>IECT</b>	<b>G</b>	Accoppiamento con Giunto / <i>Direct with coupling</i> / Direkte mit Kupplung
<b>IV</b>	—	Predisposto per accoppiamento con Unità Motrice IEC / <i>pre arrangement motor IEC</i> / geeignet für die Kombination mit Antriebseinheit IEC
	<b>N</b>	A richiesta / on Request / Auf Anfrage Predisposto per accoppiamento con Unità Motrice NEMA/ <i>pre arrangement motor NEMA</i> / geeignet für die Kombination mit Antriebseinheit NEMA - <b>CT 36 US GB</b>
<b>IS</b>	...	Grandezza IEC / <i>Size IEC</i> /



**Posizione morsettiere - Vedere - 19 - PMT - Pagina C6**  
**Terminal board position - Look - 19 - PMT - Page C6**  
**Legende des Klemmenkastens - Siehe - 19 - PMT - Auf Seite C6**

Designazione motore elettrico Se è richiesto un motoriduttore completo di motore è necessario riportare la designazione di quest'ultimo. A tale proposito consultare il ns. catalogo dei motori elettrici Electronic Line.	<i>Electric motor designation</i> For applications requiring a gearmotor, motor designation must be specified. To this end, please refer to our Electronic Line electric motor catalogue.	Bezeichnung des Elektromotors Wird ein Getriebemotor komplett mit Elektromotor angefordert, müssen dessen Daten angegeben werden. Diesbezüglich verweisen wir auf unseren Katalog der Elektromotoren "Electronic Line".
-------------------------------------------------------------------------------------------------------------------------------------------------------------------------------------------------------------------------------	----------------------------------------------------------------------------------------------------------------------------------------------------------------------------------------------	----------------------------------------------------------------------------------------------------------------------------------------------------------------------------------------------------------------------------

05 06 07	<b>UI</b>	<b>IECT - Tipo IEC e Albero Entrata</b>	<b>IECT - IEC type and Input Shaft</b>	<b>OV - IEC Typ und Antriebswelle</b>
		<b>IV - Versione Entrata</b>	<b>IV - Input Version</b>	<b>IV - Antriebsausführung</b>
		<b>IS - Albero Entrata</b>	<b>IS - Input shaft</b>	<b>IS - Antriebswelle</b>

— Nessuna indicazione = diametro standard; — No indications = standard diameter; — Keine Angabe = Standard-durchmesser

<b>UI</b>		<b>40</b>	<b>50</b>	<b>63</b>	<b>75</b>	<b>90</b>	<b>110</b>
		(Ø 11)	(Ø 14)	(Ø 18)	(Ø 24)	(Ø 24)	(Ø 28)

**14 TYPSPD - Tipo Albero uscita**

**TYPSPD - Typ output shaft**

**TYPSPD - Typ Abtriebswelle**

— Nessuna indicazione = le dimensioni dell' albero sono secondo il sistema di misura SI (mm);

— *No indications = The shaft dimensions are subject to the system of units SI (mm).*

— Keine Angabe = Die Wellendimensionen unterliegen dem Einheitensystem SI (mm)

**US** = a richiesta  
è possibile richiedere alberi con le dimensioni secondo il sistema di misura US (inch).  
**CT 36 US GB**

**US** = On request  
It's possible to request shafts dimensions according US measurement system (inch).  
**CT 36 US GB**

**US** = Auf Anfrage  
es ist möglich Wellen anzufordern, die den amerikanischen Abmessungen (inch) entsprechen.  
**CT 36 US GB**

**15 SD - Diametro Albero**

**SD - Shaft diameter**

**SD - Durchmesser Abtriebswelle**



**Diametro albero:**  
— Nessuna indicazione = diametro foro standard.

**Shaft Diameter:**  
— No indications = standard hole diameter.

**Wellendurchmesser:**  
— Keine Angabe = Standard-Bohrungsdurchmesser.

<b>UI - UMI</b>	<b>40</b>	<b>50</b>	<b>63</b>	<b>75</b>	<b>90</b>	<b>110</b>
<b>Standard (mm)</b>	18	25	25	28 (30)	35	42



## 1.2 Designazione

### 16 MPOF - Lato Flangia Uscita

— Nessuna indicazione = flangia uscita con montaggio destro (flange dal lato come indicato nelle figure);

**SIN** = flange uscita con montaggio sinistro (flange dal lato opposto alle figure indicate).

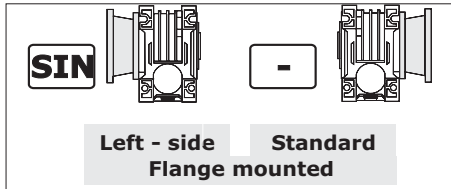

## 1.2 Designation

### MPOF - Mounting Position Output

— No indication (standard) = output flange on right side (like indicated in the figures);

**SIN** = output flange on left side (flanges on the opposite side like indicated in figures).

## 1.2 Bezeichnung

### MPOF - Montageseite Abtriebsflansch

— Keine Angabe (Standard) = Abtriebsflansch rechts (wie in den Abbildungen dargestellt)

**SIN** = Abtriebsflansch links (gegenüber der Position in den Katalogabbildungen).

### 17 MP - Posizioni di montaggio

[M2, M3, M4, M5, M6] Posizioni di montaggio con indicazione dei tappi di livello, carico e scarico; se non specificato si considera standard la posizione **M1** (vedi par. 1.4)

### MP - Mounting positions

[M2, M3, M4, M5, M6] Mounting position with indication of breather level and drain plugs; if not specified, standard position is **M1** (see par. 1.4).

### MP - Einbaulagen

Montageposition [M2, M3, M4, M5, M6] mit Angabe von . Entlüftung, Schaugläsern und Ablasschraube. Wenn nicht näher spezifiziert, wird die Standard - position **M1** zugrunde gelegt (s. Abschnitt 1.4).

### 18 OPT-ACC. - Opzioni

### OPT-ACC - Options

### OPT-ACC. - Optionen

vedi par. 1.9 see pa. 1.9 s. Abschnitt 1.9	ACC1	AL	Alberi lenti - AL	Output shafts - AL	Abtriebswellen - AL
		AL_BU	Alberi lenti Bisporgenti - AL_BU	Double Output shafts - AL_BU	Beidseitige Abtriebswellen - AL_BU
		PROT.	Coperchio di protezione	Protection cover	Schutzvorrichtungdeckel
	ACC3	BRS_VKL	Braccio Reazione Semplice_con boccola_VKL	Torque arm - Single_with VKL_bushing	Drehmomentstütze - Normal_mit VKL - Buchse
	ACC9	ELSX	Vite senza fine - Elica Sinistra	Worm Geraboxe - Left helix	Linksgängige Schraubenlinie der Schneke
vedi Sezione A-1.12 see Section A-1.12 s. Abschnitt A-1.12	OPT.	OPT	Materiale degli anelli di tenuta	Materials of Seals	Dichtungsstoffe
		OPT1	Stato fornitura olio	Scope of the supply - Options - OIL	Optionen - Lieferzustand - Optionen - Öl
		OPT2	Verniciatura	Painting and surface protection	Lackierung und Oberflächenschutzl

### 19 PMT - Posizioni della Morsettieria

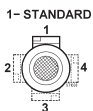

[2, 3, 4] Posizione della morsettieria del motore se diversa da quella standard (1).

**N.B.**

La configurazione standard della flangia at- tacco motore prevede 4 fori a 45°.

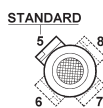

Per le flange contrassegnate con il simbolo (\*) (vedi pagina B10) i fori per il fissaggio al motore sono disposti in croce (esempio +). Pertanto è opportuno valutare l'ingombro della morsettieria del motore che verrà installato in quanto essa verrà a trovarsi orientata a 45° rispetto agli assi. Per la scelta della posizione della morsettieria rispetto agli assi fare riferimento allo schema seguente (in cui la posizione 5 è quella standard):

### PMT - Position Terminal Box

[2, 3, 4] Position of the motor terminal box if different from the standard one (1).

**Note.**

The standard configuration for the 4 holes is 45° to the axes (like an x: see par 2.3).

For the flanges marked with (\*) (see page B10) the holes to fit the motor are on the axes (like a +). Therefore we suggest to check the dimensions of the terminal board of the motor as it will be at 45° to the axes. Please choose the terminal board position referring to the following sketch (in which n° 5 is the standard position):

### PMT - Montagposition Klemmenkasten

Montageposition Klemmenkasten [2, 3, 4], wenn abweichend von Standardposition [1] (für Motortriebe).

**HINWEIS.**

In der Standardkonfiguration sind die 4 Flansch- bohrungen im 45°-Winkel zu den Achsen angeordnet

Bei Flanschen, die mit (\*) (Siehe auf Seite B10) gekennzeichnet sind, sind die Bohrungen auf den Achsen angeordnet (wie ein +). Es sollte deshalb der Platzbedarf des Motorklemmenkastens beachtet werden, da er sich in 45°-Position zu den Achsen befinden wird. Die Lage des Klemmenkastens des Motors wählen Sie bitte anhand der folgenden Skizze (Pos. 5 ist Standardposition):



1.4 Lubrificazione

1.4 Lubrication

1.4 Schmierung



Posizioni di montaggio  
Mounting positions  
Montagepositionen

UI - UMI

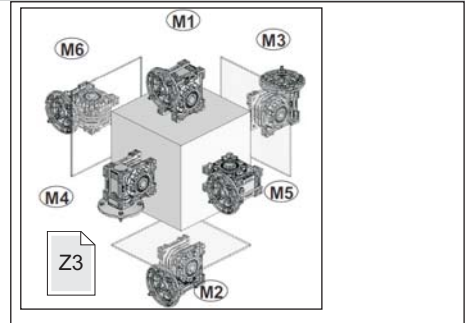
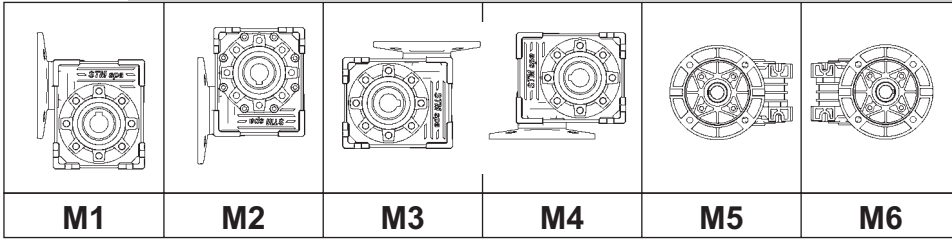

Posizioni di montaggio - Mounting positions - Montagepositionen			
UI UMI		Posizioni Positions Positionen	Prescrizioni da indicare in fase d'ordine Ordering requirements Anforderungen bei der Bestellung
	40	M1-M2 M3-M4 M5-M6	Non necessaria Not necessary Nicht erforderlich
	50		
	63		
	75		
	90	M1-M2 M3-M4 M5-M6	Necessaria Necessary Erforderlich
110			

**M3-M4**  
Particolare attenzione va posta per i riduttori montati nelle posizioni M3 e M4 che sono forniti con il cuscinetto schermato.

**M3-M4**  
Particular attention should be paid to worm gearboxes with a shielded bearing mounted in positions M3 and M4.

**M3-M4**  
Besondere Aufmerksamkeit sollte den Getrieben zukommen, die in den Einbautagen M3 und M4 montiert werden und mit abgeschirmtem Lager geliefert werden.

TARGHETTA - RIDUTTORE

**NON NECESSARIA**  
Indicata sempre nella targhetta del riduttore la posizione di montaggio "M1".

Identification Plate - Gearbox

**NOT NECESSARY**  
The mounting position is always indicated on the nameplate "M1".

Typeschild - Getriebe

**NICHT ERFORDERLICH**  
Die Einbaulage ist immer auf dem Typenschild angegeben "M1".

**NECESSARIA**  
La posizione richiesta è indicata nella targhetta del riduttore

**NECESSARY**  
The indication it on the label of the gearbox

**ERFORDERLICH**  
Findet man die angefragte Position auf dem Typenschild des Getriebe

Lub	Quantità di lubrificante - Lubricant Quantity - Schmiermittelmenge - [Kg]							OPT1	Tappi-Plug-Stopfen		
		M1	M2	M3	M4	M5	M6		N°	Diameter	Type
UI UMI	UI-UMI	40	0.060					INOIL_STD	1	1/4"	
		UI	0.170						1		
	UMI	0.105					1				
	UI	0.350					1				
	UMI	0.240					1				
	UI-UMI	0.450					1				
	UI-UMI	90	1.000	0.600			1		3/8"		
		110	1.600	1.300							

**Attenzione !:**  
Il tappo di sfiato è allegato solo nei riduttori che hanno più di un tappo olio

**Warning!:**  
A breather plug is supplied only with worm gearboxes that have more than one oil plug

**Achtung!:**  
Der Entlüftungstopfen ist lediglich bei den Getrieben vorhanden, die über mehr als einen Öfüllstopfen verfügen

**Nota:** Se in fase d'ordine la posizione di montaggio è omessa, il riduttore verrà fornito con i tappi predisposti per la posizione M1.

**Note:** If the mounting position is not specified in the order, the worm gearbox supplied will have plugs pre-arranged for position M1.

**Anmerkung:** Sollte in der Auftragsphase die Einbaulage nicht angegeben werden, wird das Getriebe mit Stopfen für die Einbaulage M1.

Eventuali forniture con predisposizioni tappi diverse da quella indicata in tabella, dovranno essere concordate.

The supply of gearboxes with different plug pre-arrangements has to be agreed with the manufacturer.

Lieferungen, die eine Auslegung hinsichtlich der Stopfen aufweisen, die von den Angaben in der Tabelle abweichen, müssen vorab vereinbart werden..



### 1.5 Carichi radiali e assiali

Quando la trasmissione del moto avviene tramite meccanismi che generano carichi radiali sull'estremità dell'albero, è necessario verificare che i valori risultanti non eccedono quelli indicati nelle tabelle.

Nella Tab. 2.5 sono riportati i valori dei carichi radiali ammissibili per l'albero veloce ( $Fr_1$ ). Come carico assiale ammissibile contemporaneo si ha:

$$Fa_1 = 0.2 \times Fr_1$$

Tab. 2.5



**UI**

$n_1$ min <sup>-1</sup>	$Fr_1$ (N)					
	UI					
	40	50	63	75	90	110
<b>2800</b>	187	272	357	510	700	850
<b>1400</b>	220	320	420	600	800	1000
<b>900</b>	250	350	460	660	900	1200
<b>700</b>	280	400	500	730	1000	1300
<b>500</b>	310	450	530	800	1100	1450

In Tab. 2.7 sono riportati i valori dei carichi radiali ammissibili per l'albero lento ( $Fr_2$ ). Come carico assiale ammissibile contemporaneo si ha:

$$Fa_2 = 0.2 \times Fr_2$$

Tab. 2.7



**UI  
UMI**

$n_2$ min <sup>-1</sup>	$Fr_2$ (N)					
	UI - UMI					
	40	50	63	75	90	110
<b>400</b>	686	925	946	1400	1897	2168
<b>280</b>	808	1088	1114	1700	2232	2550
<b>200</b>	950	1280	1310	2000	2625	3000
<b>140</b>	1050	1450	1680	2300	2775	3150
<b>93</b>	1200	1620	1740	2600	3050	3600
<b>70</b>	1350	1850	1930	2800	3400	4150
<b>50</b>	1500	2100	2150	3400	4205	4850
<b>35</b>	1600	2230	2300	3700	4775	5700
<b>29</b>	1700	2400	2500	4100	5300	6200
<b>25</b>	1800	2580	2700	4300	5610	6600
<b>20</b>	1950	2700	2900	4700	6175	7200
<b>18</b>	2100	2850	3100	4900	6650	7800
<b>14</b>	2300	3200	3300	5200	7025	8250

A richiesta possono essere fornite versioni rinforzate con cuscinetti a rulli conici sulla corona in grado di sopportare carichi superiori a quelli ammessi dalle versioni normali.

Si veda a tal proposito la tabella 2.9, in cui sono riportati i valori dei carichi radiali e assiali ammissibili sull'albero uscita nel caso di cuscinetti conici sulla corona. Si consiglia, in questi casi, di adottare versioni flangiate, verificando che il carico assiale venga interamente assorbito dal cuscinetto alloggiato nella flangia di fissaggio.

### 1.5 Axial and overhung loads

Should transmission movement determine radial loads on the angular shaft end, it is necessary to make sure that resulting values do not exceed the ones indicated in the tables.

In Table 2.5 permissible radial load for input shaft are listed ( $Fr_1$ ). Contemporary permissible axial load is given by the following formula:

$$Fa_1 = 0.2 \times Fr_1$$

### 1.5 Radiale und Axiale Belastungen

Wird das Wellenende auch durch Radialkräfte belastet, so muß sichergestellt werden, daß die resultierenden Werte die in der Tabelle angegebenen nicht überschreiten.

In Tabelle 2.5 sind die Werte der zulässigen Radialbelastungen für die Antriebswelle ( $Fr_1$ ) angegeben. Die Axialbelastung beträgt dann:

$$Fa_1 = 0.2 \times Fr_1$$

In Table 2.7 permissible radial loads for output shaft are listed ( $Fr_2$ ). Permissible axial load is given by the following formula:

$$Fa_2 = 0.2 \times Fr_2$$

In Tabelle 2.7 sind die Werte der zulässigen Radialbelastungen für die Abtriebswelle angegeben.

Als zulässige Axialbelastung gilt:

$$Fa_2 = 0.2 \times Fr_2$$

In order to increase the load capacity of the gearboxes it is possible to fit taper roller bearings on to the output shaft. Such reinforced versions are available upon request.

With regard to this reinforced version, let see output radial and axial load values shown on tab. 2.9. It's advisable to use flange mounted versions and to make sure that the axial load is absorbed by the bearing, housed in the fixing flange.

Für größere Belastungen stehen auf Wunsch auch verstärkte Ausführungen mit Kegelrollenlagern für die Schneckenwelle zur Verfügung.

Tabelle 2.9 listet die zulässigen Radial- und Axiallasten bei Verwendung von Kegelrollenlagern auf. Es wird in diesen Fällen empfohlen, Flanschausführungen zu verwenden und sicherzustellen, daß die axiale Last vollständig vom Lager, das sich im Befestigungsflansch befindet, aufgenommen wird.





Tab. 2.9



UI  
UMI

CARICHI RADIALI - ASSIALI CON CUSCINETTI CONICI SULLA CORONA AXIAL AND OVERHUNG LOADS WITH TAPER ROLLER BEARINGS ON WORMWHEEL RADIALE UND AXIALE BELASTUNGEN MIT KEGELROLLENLAGERN AUF DEM SCHNECKENRAD												
n <sub>2</sub> (rpm)	UI - UMI											
	40		50		63		75		90		110	
	Fr <sub>2</sub>	Fa <sub>2</sub>	Fr <sub>2</sub>	Fa <sub>2</sub>	Fr <sub>2</sub>	Fa <sub>2</sub>	Fr <sub>2</sub>	Fa <sub>2</sub>	Fr <sub>2</sub>	Fa <sub>2</sub>	Fr <sub>2</sub>	Fa <sub>2</sub>
400	2076	2708	4603	5325	4693	5415	5415	6588	6543	8529	7671	9837
280	2185	2850	4845	5605	4940	5700	5700	6935	6888	8978	8075	10355
200	2300	3000	5100	5900	5200	6000	6000	7300	7250	9450	8500	10900
140	2300	3000	5600	6500	5750	6650	6700	8200	7900	10300	9200	11800
93	2300	3000	6300	7300	6500	7550	7500	9150	8400	10950	9200	11800
70	2300	3000	6550	7600	6200	7200	7600	9300	7850	10225	9200	11800
50	2300	3000	6900	8000	6900	8000	8700	10600	9250	12050	10600	13600
35	2300	3000	6900	8000	6900	8000	9000	11000	11450	14900	13900	13600
29	2300	3000	6900	8000	6900	8000	9000	11000	11900	15500	14800	17800
25	2300	3000	6900	8000	6900	8000	9000	11000	11900	15500	14800	19000
20	2300	3000	6900	8000	6900	8000	9000	11000	11900	15500	14800	19000
18	2300	3000	6900	8000	6900	8000	9000	11000	11900	15500	14800	19000

I carichi radiali indicati nelle tabelle si intendono applicati a metà della sporgenza dell'albero e sono riferiti ai riduttori operanti con fattore di servizio 1.

Valori intermedi relativi a velocità non riportate possono essere ottenuti per interpolazione considerando però che Fr<sub>1</sub> a 500 min<sup>-1</sup> e Fr<sub>2</sub> a 14 min<sup>-1</sup> rappresentano i carichi massimi consentiti.

Per i carichi non agenti sulla mezzeria dell'albero lento o veloce si ha:

*The radial loads shown in the tables are applied on the centre line of the shaft extension and are related to gearboxes working with service factor 1.*

*Intermediate values of speeds that are not listed can be obtained through interpolation but it must be considered that Fr<sub>1</sub> at 500 min<sup>-1</sup> and Fr<sub>2</sub> at 14 min<sup>-1</sup> represent the maximum allowable loads.*

*For loads which are not applied on the centre line of the output or input shaft, following values will be obtained:*

Bei den in der Tabelle angegebenen Radialbelastungen wird eine Kräfteinwirkung auf die Mitte des Wellenendes zugrunde gelegt; außerdem arbeiten die Getriebe mit Betriebsfaktor 1. Zwischenwerte für nicht aufgeführte Drehzahlen können durch Interpolation ermittelt werden. Hierbei ist jedoch zu berücksichtigen, daß die Werte von Fr<sub>1</sub> bei 500 min<sup>-1</sup> und von Fr<sub>2</sub> bei 14 min<sup>-1</sup> die Maximalbelastungen repräsentieren.

Bei Lasten, die nicht auf die Mitte der Ab- bzw. Antriebswellen wirken, legt man folgende Werte zugrunde:

a 0.3 della sporgenza:  
 $Fr_x = 1.25 \times Fr_{1-2}$

a 0.8 dalla sporgenza:  
 $Fr_x = 0.8 \times Fr_{1-2}$

at 0.3 from extension:  
 $Fr_x = 1.25 \times Fr_{1-2}$

at 0.8 from extension:  
 $Fr_x = 0.8 \times Fr_{1-2}$

0.3 vom Wellenabsatz:  
 $Fr_x = 1.25 \times Fr_{1-2}$

0.8 vom Wellenabsatz:  
 $Fr_x = 0.8 \times Fr_{1-2}$

Tab. 2.11

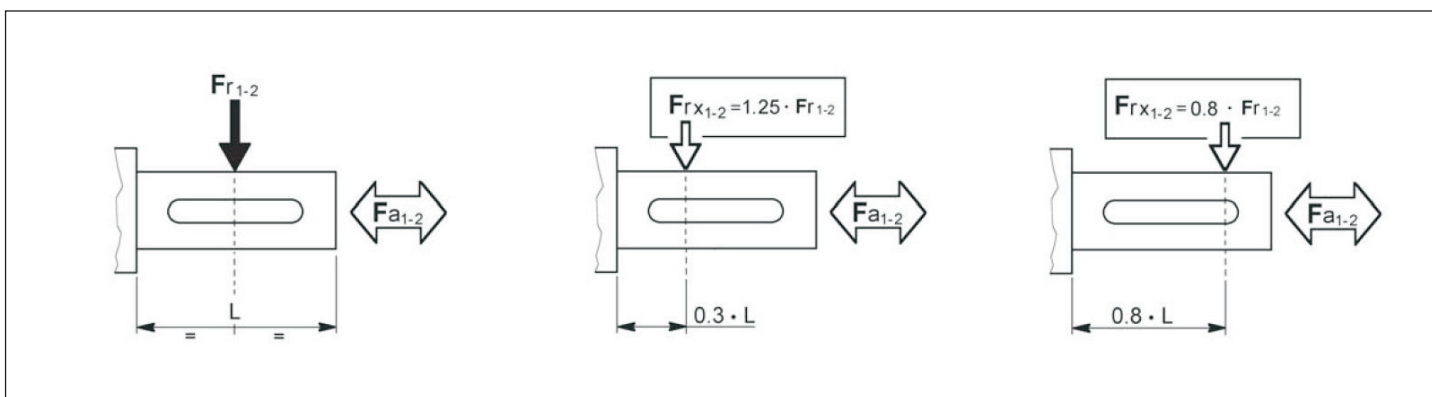



1.6 Prestazioni riduttori UI

1.6 UI Gearboxes performances

1.6 Leistungen der UI-Getriebe

UI 40



2.1

ir	n <sub>1</sub> = 2800 min <sup>-1</sup> ⚠				n <sub>1</sub> = 1400 min <sup>-1</sup>				n <sub>1</sub> = 900 min <sup>-1</sup>				n <sub>1</sub> = 500 min <sup>-1</sup>				IEC
	n <sub>2</sub> min <sup>-1</sup>	T <sub>2M</sub> Nm	P kW	RD %	n <sub>2</sub> min <sup>-1</sup>	T <sub>2M</sub> Nm	P kW	RD %	n <sub>2</sub> min <sup>-1</sup>	T <sub>2M</sub> Nm	P kW	RD %	n <sub>2</sub> min <sup>-1</sup>	T <sub>2M</sub> Nm	P kW	RD %	
5	560	27	1.8	86	280	37	1.28	85	180	44	1.00	83	100	54	0.69	82	71-63-56
7	400	27	1.3	84	200	37	0.93	83	129	44	0.73	81	71	54	0.50	80	
10	280	31	1.1	83	140	42	0.76	81	90	49	0.58	79	50	59	0.40	78	
15	187	32	0.78	80	93	42	0.53	77	60	49	0.41	75	33	59	0.28	73	
20	140	29	0.56	76	70	37	0.37	73	45	43	0.29	70	25	51	0.20	67	
28	100	34	0.50	71	50	43	0.34	67	32	50	0.26	64	17.9	59	0.18	61	
40	70	32	0.36	65	35	40	0.24	60	23	45	0.19	56	12.5	53	0.13	53	
49	57	30	0.29	62	29	38	0.20	57	18.4	43	0.16	53	10.2	50	0.11	49	
56	50	28	0.24	60	25	36	0.17	54	16.1	40	0.13	51	8.9	47	0.09	47	
70	40	23	0.18	53	20	28	0.12	47	12.9	32	0.10	44	7.1	37	0.07	39	
80	35	21	0.15	50	17.5	26	0.11	44	11.3	29	0.09	40	6.3	34	0.06	36	
100	28	23	0.13	51	14.0	28	0.09	45	9.0	30	0.07	41	5.0	31	0.04	38	

UI 50



3.5

ir	n <sub>1</sub> = 2800 min <sup>-1</sup> ⚠				n <sub>1</sub> = 1400 min <sup>-1</sup>				n <sub>1</sub> = 900 min <sup>-1</sup>				n <sub>1</sub> = 500 min <sup>-1</sup>				IEC
	n <sub>2</sub> min <sup>-1</sup>	T <sub>2M</sub> Nm	P kW	RD %	n <sub>2</sub> min <sup>-1</sup>	T <sub>2M</sub> Nm	P kW	RD %	n <sub>2</sub> min <sup>-1</sup>	T <sub>2M</sub> Nm	P kW	RD %	n <sub>2</sub> min <sup>-1</sup>	T <sub>2M</sub> Nm	P kW	RD %	
5	560	45	3.0	87	280	65	2.2	86	180	75	1.7	85	100	95	1.18	84	80-71-63
7	400	50	2.5	85	200	68	1.7	84	129	81	1.3	83	71	100	0.91	82	
10	280	55	1.9	84	140	73	1.3	82	90	86	1.0	81	50	105	0.70	79	
15	187	58	1.4	82	93	76	0.93	80	60	89	0.71	79	33	106	0.48	77	
20	140	57	1.1	79	70	74	0.71	76	45	86	0.55	74	25	102	0.38	71	
28	100	62	0.88	74	50	80	0.60	70	32	92	0.46	67	17.9	109	0.32	64	
40	70	64	0.67	70	35	81	0.45	66	23	92	0.34	63	12.5	108	0.24	59	
49	57	57	0.51	67	29	72	0.34	63	18.4	82	0.27	59	10.2	96	0.19	55	
56	50	55	0.44	65	25	69	0.30	60	16.1	78	0.23	56	8.9	91	0.16	53	
70	40	52	0.36	61	20	64	0.24	56	12.9	72	0.19	52	7.1	84	0.13	48	
80	35	47	0.30	57	17.5	58	0.21	51	11.3	66	0.17	47	6.3	75	0.11	43	
100	28	42	0.23	54	14.0	52	0.16	48	9.0	59	0.13	44	5.0	60	0.08	40	

UI 63



6.0

ir	n <sub>1</sub> = 2800 min <sup>-1</sup> ⚠				n <sub>1</sub> = 1400 min <sup>-1</sup>				n <sub>1</sub> = 900 min <sup>-1</sup>				n <sub>1</sub> = 500 min <sup>-1</sup>				IEC
	n <sub>2</sub> min <sup>-1</sup>	T <sub>2M</sub> Nm	P kW	RD %	n <sub>2</sub> min <sup>-1</sup>	T <sub>2M</sub> Nm	P kW	RD %	n <sub>2</sub> min <sup>-1</sup>	T <sub>2M</sub> Nm	P kW	RD %	n <sub>2</sub> min <sup>-1</sup>	T <sub>2M</sub> Nm	P kW	RD %	
5	560	79	5.3	88	280	110	3.8	86	180	132	2.9	86	100	164	2.0	85	90-80-71
7	400	84	4.1	86	200	115	2.9	84	129	137	2.2	84	71	169	1.5	83	
10	280	93	3.2	84	140	126	2.2	83	90	149	1.7	81	50	182	1.2	80	
15	187	98	2.3	82	93	131	1.6	80	60	153	1.2	78	33	184	0.85	76	
20	140	104	1.9	80	70	136	1.3	77	45	158	0.99	75	25	189	0.69	72	
28	100	105	1.5	75	50	135	1.0	71	32	156	0.77	68	17.9	186	0.54	65	
40	70	113	1.2	71	35	145	0.79	67	23	166	0.61	64	12.5	195	0.43	60	
49	57	98	0.85	69	29	125	0.58	64	18.4	142	0.45	61	10.2	166	0.31	57	
56	50	101	0.79	67	25	127	0.54	62	16.1	145	0.42	58	8.9	169	0.29	54	
70	40	94	0.62	63	20	117	0.42	58	12.9	133	0.33	54	7.1	154	0.23	50	
80	35	88	0.53	61	17.5	110	0.37	55	11.3	124	0.29	51	6.3	144	0.20	47	
100	28	80	0.41	57	14.0	99	0.28	51	9.0	112	0.22	47	5.0	125	0.15	43	

⚠ ATTENZIONE!

Per situazioni con velocità di ingresso particolari attenersi alla tabella pagina A2.

I pesi riportati sono indicativi e possono variare in funzione della versione del riduttore.

N.B. Per i riduttori evidenziati dal doppio bordo nella colonna delle potenze è necessario verificare lo scambio termico del riduttore (come nel par. 1.7-A). Per maggiori informazioni contattare l'ufficio tecnico STM.

⚠ WARNING!

If in presence of non standard input speed please attain to the page A2.

Listed weights are for reference only and can vary according to the gearbox version.

NOTE. Please pay attention to the frame around the input power value: for this gearboxes it's important to check the thermal capacity (comp. chapter 1.7-A). For details please contact our technical department.

⚠ ACHTUNG!

Mit unstandardisierte Antriebsgeschwindigkeit bitte auf Seite A2.

Die angegebenen Gewichte sind Richtwerte und können je nach Getriebeversion etwas variieren.

HINWEIS. Sind in den Tabellen Nennleistungen eingerahmt, so ist die thermische Leistungsgrenze der Getriebe zu beachten (s. S. 1.7-A). Für weitere Informationen wenden Sie sich bitte an unser technisches Büro.

1.6 Prestazioni riduttori UI

1.6 UI Gearboxes performances

1.6 Leistungen der UI-Getriebe

UI 75

9.0

ir	n <sub>1</sub> = 2800 min <sup>-1</sup> ⚠				n <sub>1</sub> = 1400 min <sup>-1</sup>				n <sub>1</sub> = 900 min <sup>-1</sup>				n <sub>1</sub> = 500 min <sup>-1</sup>				IEC
	n <sub>2</sub> min <sup>-1</sup>	T <sub>2M</sub> Nm	P kW	RD %	n <sub>2</sub> min <sup>-1</sup>	T <sub>2M</sub> Nm	P kW	RD %	n <sub>2</sub> min <sup>-1</sup>	T <sub>2M</sub> Nm	P kW	RD %	n <sub>2</sub> min <sup>-1</sup>	T <sub>2M</sub> Nm	P kW	RD %	
7	400	146	7,11	86	200	205	5,05	85	129	241	3,86	84	71	298	2,69	83	100-112 90-80
10	280	163	5,66	85	140	220	3,86	84	90	261	2,98	83	50	320	2,08	81	
15	187	173	4,12	82	93	230	2,79	81	60	270	2,16	79	33	325	1,48	77	
20	140	161	2,93	81	70	220	2,07	78	45	245	1,52	76	25	293	1,05	73	
28	100	193	2,71	75	50	255	1,87	72	32	290	1,42	69	18	345	1,00	65	
40	70	176	1,80	72	35	230	1,24	68	23	258	0,94	65	13	303	0,65	61	
49	57	169	1,47	69	29	220	1,02	65	18	245	0,77	61	10	287	0,54	57	
56	50	153	1,17	69	25	200	0,82	64	16	219	0,61	60	9	256	0,43	56	
70	40	153	1,00	64	20	195	0,69	59	13	217	0,53	56	7	252	0,37	51	
80	35	145	0,86	62	18	185	0,61	56	11	205	0,46	52	6	237	0,32	48	
100	28	131	0,66	59	14	170	0,48	52	9	183	0,36	49	5	206	0,25	44	

UI 90

14.0

ir	n <sub>1</sub> = 2800 min <sup>-1</sup> ⚠				n <sub>1</sub> = 1400 min <sup>-1</sup>				n <sub>1</sub> = 900 min <sup>-1</sup>				n <sub>1</sub> = 500 min <sup>-1</sup>				IEC
	n <sub>2</sub> min <sup>-1</sup>	T <sub>2M</sub> Nm	P kW	RD %	n <sub>2</sub> min <sup>-1</sup>	T <sub>2M</sub> Nm	P kW	RD %	n <sub>2</sub> min <sup>-1</sup>	T <sub>2M</sub> Nm	P kW	RD %	n <sub>2</sub> min <sup>-1</sup>	T <sub>2M</sub> Nm	P kW	RD %	
7	400	230	11,2	86	200	320	7,8	86	129	382	6,1	85	71	474	4,2	84	100-112 90-80
10	280	255	8,8	85	140	347	6,0	85	90	412	4,6	84	50	505	3,2	82	
15	187	278	6,6	83	93	371	4,4	82	60	436	3,4	80	33	526	2,4	78	
20	140	290	5,2	82	70	381	3,5	80	45	444	2,7	78	25	531	1,9	75	
28	100	318	4,4	76	50	414	2,9	74	32	480	2,3	71	18	572	1,6	67	
40	70	316	3,2	73	35	406	2,1	71	23	466	1,6	67	13	550	1,1	64	
49	57	290	2,4	71	29	368	1,6	67	18	421	1,3	64	10	494	0,9	60	
56	50	272	2,0	71	25	344	1,3	68	16	392	1,0	63	9	458	0,7	59	
70	40	246	1,5	67	20	309	1,0	63	13	350	0,8	59	7	408	0,6	54	
80	35	238	1,4	65	18	297	0,9	60	11	336	0,7	56	6	390	0,5	52	
100	28	217	1,1	61	14	270	0,7	55	9	296	0,5	52	5	313	0,4	47	

UI 110

22.0

ir	n <sub>1</sub> = 2800 min <sup>-1</sup> ⚠				n <sub>1</sub> = 1400 min <sup>-1</sup>				n <sub>1</sub> = 900 min <sup>-1</sup>				n <sub>1</sub> = 500 min <sup>-1</sup>				IEC
	n <sub>2</sub> min <sup>-1</sup>	T <sub>2M</sub> Nm	P kW	RD %	n <sub>2</sub> min <sup>-1</sup>	T <sub>2M</sub> Nm	P kW	RD %	n <sub>2</sub> min <sup>-1</sup>	T <sub>2M</sub> Nm	P kW	RD %	n <sub>2</sub> min <sup>-1</sup>	T <sub>2M</sub> Nm	P kW	RD %	
7	400	341	16,6	86	200	478	11,6	86	129	577	9,1	85	71	720	6,4	84	132 112-100-90
10	280	391	13,5	85	140	537	9,3	85	90	640	7,2	84	50	788	5,0	82	
15	187	396	9,3	83	93	535	6,4	82	60	632	5,0	80	33	769	3,4	78	
20	140	465	8,3	82	70	617	5,6	81	45	722	4,3	79	25	869	3,0	76	
28	100	433	5,9	77	50	570	4,0	75	32	665	3,1	72	17,9	796	2,2	69	
40	70	493	4,9	74	35	638	3,2	72	23	737	2,6	68	12,5	873	1,8	65	
49	57	452	3,8	72	29	581	2,5	69	18,4	667	1,9	66	10,2	786	1,4	62	
56	50	364	2,7	71	25	465	1,8	69	16,1	532	1,4	64	8,9	624	0,97	60	
70	40	381	2,3	68	20	483	1,6	64	12,9	551	1,2	60	7,1	644	0,88	55	
80	35	390	2,2	66	17,5	491	1,5	62	11,3	559	1,1	58	6,3	651	0,80	53	
100	28	355	1,7	62	14,0	444	1,1	57	9,0	503	0,89	53	5,0	583	0,62	49	

⚠ ATTENZIONE!

Per situazioni con velocità di ingresso particolari attenersi alla tabella pagina A2.

I pesi riportati sono indicativi e possono variare in funzione della versione del riduttore.

N.B. Per i riduttori evidenziati dal doppio bordo nella colonna delle potenze è necessario verificare lo scambio termico del riduttore (come nel par. 1.7-A). Per maggiori informazioni contattare l'ufficio tecnico STM.

⚠ WARNING!

If in presence of non standard input speed please attain to the page A2.

Listed weights are for reference only and can vary according to the gearbox version.

NOTE. Please pay attention to the frame around the input power value: for this gearboxes it's important to check the thermal capacity (comp. chapter 1.7-A). For details please contact our technical department.

⚠ ACHTUNG!

Mit unstandardisierte Antriebsgeschwindigkeit bitte auf Seite A2.

Die angegebenen Gewichte sind Richtwerte und können je nach Getriebeversion etwas variieren.

HINWEIS. Sind in den Tabellen Nennleistungen eingerahmt, so ist die thermische Leistungsgrenze der Getriebe zu beachten (s. S. 1.7-A). Für weitere Informationen wenden Sie sich bitte an unser technisches Büro.

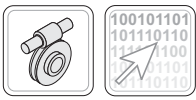

### 1.7 Prestazioni motoriduttori

$n_2$ min <sup>-1</sup>	ir	T2 Nm	FS'		
----------------------------	----	----------	-----	--	--

<b>0.09 kW</b>	$n_1 = 2740 \text{ min}^{-1}$ $n_1 = 1360 \text{ min}^{-1}$ $n_1 = 860 \text{ min}^{-1}$	56A 2 56B 4 63B 6
----------------	------------------------------------------------------------------------------------------------	-------------------------

49	28	12	3.6	UMI 40	56B 4
43	20	14	3.1	UMI 40	63B 6
34	40	15	2.6	UMI 40	56B 4
31	28	18	2.8	UMI 40	63B 6
28	49	18	2.2	UMI 40	56B 4
24	56	19	1.9	UMI 40	56B 4
19.4	70	21	1.3	UMI 40	56B 4
17.0	80	22	1.2	UMI 40	56B 4
15.4	56	29	1.4	UMI 40	63B 6
13.6	100	28	1.0	UMI 40	56B 4
12.3	70	31	1.0	UMI 40	63B 6

<b>0.11 kW</b>	$n_1 = 1360 \text{ min}^{-1}$	56C 4
----------------	-------------------------------	-------

68	20	11	3.3	UMI 40	56C 4
49	28	14	3.0	UMI 40	56C 4
34	40	19	2.2	UMI 40	56C 4
28	49	22	1.8	UMI 40	56C 4
24	56	23	1.5	UMI 40	56C 4
19.4	70	25	1.1	UMI 40	56C 4
17.0	80	27	1.0	UMI 40	56C 4
13.6	100	35	0.8	UMI 40	56C 4

<b>0.13 kW</b>	$n_1 = 2750 \text{ min}^{-1}$ $n_1 = 1360 \text{ min}^{-1}$ $n_1 = 860 \text{ min}^{-1}$	56B 2 63A 4 63C 6
----------------	------------------------------------------------------------------------------------------------	-------------------------

550	5	2.1	13.0	UMI 40	56B 2
393	7	3	10.2	UMI 40	56B 2
393	7	3	9.8	UMI 40	56B 2
275	10	4	8.3	UMI 40	56B 2
275	10	4	8.0	UMI 40	56B 2
268	5	3.9	9.4	UMI 40	63A 4
194	7	5	7.0	UMI 40	63A 4
136	10	7	5.7	UMI 40	63A 4
91	15	11	4.0	UMI 40	63A 4
68	20	13	2.8	UMI 40	63A 4
56	49	14	2.2	UMI 40	56B 2
56	49	14	2.1	UMI 40	56B 2
49	28	17	2.5	UMI 40	63A 4
34	40	24	3.4	UMI 50	63A 4
34	40	22	1.8	UMI 40	63A 4
28	49	28	2.6	UMI 50	63A 4
28	49	25	1.5	UMI 40	63A 4
24	56	31	2.2	UMI 50	63A 4
24	56	28	1.3	UMI 40	63A 4
22	40	36	2.5	UMI 50	63C 6
22	40	32	1.4	UMI 40	63C 6
19.4	70	36	1.8	UMI 50	63A 4
19.4	70	30	0.9	UMI 40	63A 4
17.0	80	37	1.6	UMI 50	63A 4
17.0	80	32	0.8	UMI 40	63A 4
13.6	100	44	1.2	UMI 50	63A 4
12.3	70	53	1.4	UMI 50	63C 6
8.6	100	64	0.9	UMI 50	63C 6

$n_2$ min <sup>-1</sup>	ir	T2 Nm	FS'		
----------------------------	----	----------	-----	--	--

<b>0.18 kW</b>	$n_1 = 2760 \text{ min}^{-1}$ $n_1 = 1370 \text{ min}^{-1}$ $n_1 = 870 \text{ min}^{-1}$	63A 2 63B 4 71A 6
----------------	------------------------------------------------------------------------------------------------	-------------------------

554	5	2.7	10.0	UMI 40	63A 2
394	7	4	7.4	UMI 40	63A 2
276	10	5	6.0	UMI 40	63A 2
272	5	5.5	6.8	UMI 40	63B 4
196	7	7	5.1	UMI 40	63B 4
137	10	10	4.1	UMI 40	63B 4
124	7	11	3.9	UMI 40	71A 6
91	15	14	2.9	UMI 40	63B 4
69	20	18	2.0	UMI 40	63B 4
58	15	22	2.2	UMI 40	71A 6
49	28	25	3.3	UMI 50	63B 4
49	28	24	1.8	UMI 40	63B 4
44	20	29	2.9	UMI 50	71A 6
44	20	28	1.6	UMI 40	71A 6
34	40	33	2.4	UMI 50	63B 4
34	40	30	1.3	UMI 40	63B 4
28	49	39	1.9	UMI 50	63B 4
28	49	35	1.1	UMI 40	63B 4
24	56	42	1.6	UMI 50	63B 4
24	56	38	0.9	UMI 40	63B 4
19.6	70	49	1.3	UMI 50	63B 4
17.1	80	51	1.1	UMI 50	63B 4
15.5	56	64	2.3	UMI 63	71A 6
15.5	56	62	1.3	UMI 50	71A 6
13.7	100	60	0.9	UMI 50	63B 4
12.4	70	75	1.8	UMI 63	71A 6
12.4	70	72	1.0	UMI 50	71A 6
10.9	80	81	1.5	UMI 63	71A 6
10.9	80	74	0.9	UMI 50	71A 6
8.7	100	93	1.2	UMI 63	71A 6

<b>0.22 kW</b>	$n_1 = 1400 \text{ min}^{-1}$	63C 4
----------------	-------------------------------	-------

272	5	6.6	5.6	UMI 40	63C 4
200	7	9	4.2	UMI 40	63C 4
140	10	12	3.5	UMI 40	63C 4
93	15	17	2.4	UMI 40	63C 4
70	20	22	1.7	UMI 40	63C 4
50	28	29	2.7	UMI 50	63C 4
50	28	28	1.5	UMI 40	63C 4
35	40	40	2.0	UMI 50	63C 4
35	40	36	1.1	UMI 40	63C 4
29	49	46	1.6	UMI 50	63C 4
29	49	42	0.9	UMI 40	63C 4
25	56	50	1.4	UMI 50	63C 4
20	70	59	1.1	UMI 50	63C 4

### 1.7 Leistungen der Getriebemotoren

$n_2$ min <sup>-1</sup>	ir	T2 Nm	FS'		
----------------------------	----	----------	-----	--	--

<b>0.25 kW</b>	$n_1 = 2790 \text{ min}^{-1}$ $n_1 = 1370 \text{ min}^{-1}$ $n_1 = 870 \text{ min}^{-1}$	63B 2 71A 4 71B 6
----------------	------------------------------------------------------------------------------------------------	-------------------------

564	5	3.6	7.5	UMI 40	63B 2
399	7	5	5.4	UMI 40	63B 2
282	5	7.2	5.1	UMI 40	71A 4
279	10	7	4.4	UMI 40	63B 2
196	7	10	6.6	UMI 50	71A 4
196	7	10	3.7	UMI 40	71A 4
137	10	14	5.1	UMI 50	71A 4
137	10	14	3.0	UMI 40	71A 4
124	7	16	5.1	UMI 50	71B 6
124	7	16	2.8	UMI 40	71B 6
91	15	21	3.6	UMI 50	71A 4
91	15	20	2.1	UMI 40	71A 4
69	20	26	2.8	UMI 50	71A 4
69	20	25	1.5	UMI 40	71A 4
58	15	33	2.7	UMI 50	71B 6
58	15	31	1.6	UMI 40	71B 6
49	28	34	2.3	UMI 50	71A 4
49	28	33	1.3	UMI 40	71A 4
44	20	41	2.1	UMI 50	71B 6
44	20	38	1.1	UMI 40	71B 6
34	40	47	3.1	UMI 63	71A 4
34	40	46	1.8	UMI 50	71A 4
31	28	52	3.0	UMI 63	71B 6
31	28	51	1.8	UMI 50	71B 6
31	28	49	1.0	UMI 40	71B 6
28	49	55	2.3	UMI 63	71A 4
28	49	54	1.3	UMI 50	71A 4
24	56	61	2.1	UMI 63	71A 4
24	56	59	1.2	UMI 50	71A 4
22	40	70	2.4	UMI 63	71B 6
22	40	69	1.3	UMI 50	71B 6
19.6	70	71	1.7	UMI 63	71A 4
19.6	70	68	0.9	UMI 50	71A 4
17.1	80	77	1.4	UMI 63	71A 4
17.1	80	71	0.8	UMI 50	71A 4
15.5	56	89	1.6	UMI 63	71B 6
15.5	56	86	0.9	UMI 50	71B 6
13.7	100	89	1.1	UMI 63	71A 4
12.4	70	104	1.3	UMI 63	71B 6
10.9	80	112	1.1	UMI 63	71B 6

<b>0.37 kW</b>	$n_1 = 2790 \text{ min}^{-1}$ $n_1 = 2790 \text{ min}^{-1}$ $n_1 = 1380 \text{ min}^{-1}$ $n_1 = 910 \text{ min}^{-1}$	63C 2 71A 2 71B 4 80A 6
----------------	---------------------------------------------------------------------------------------------------------------------------------	----------------------------------

572	5	5.3	5.0	UMI 40	71A 2
560	5	5.4	5.0	UMI 40	63C 2
399	7	7	3.6	UMI 40	71A 2
399	7	7	3.6	UMI 40	63C 2
279	10	11	2.9	UMI 40	71A 2
279	10	11	2.9	UMI 40	63C 2
274	5	11	3.4	UMI 40	71B 4
197	7	15	4.5	UMI 50	71B 4
197	7	15	2.5	UMI 40	71B 4
186	15	16	3.7	UMI 50	71A 2
186	15	15	2.1	UMI 40	71A 2
186	15	15	2.1	UMI 40	63C 2



### 1.7 Prestazioni motoriduttori

$n_2$ min <sup>-1</sup>	ir	T2 Nm	FS'		
----------------------------	----	----------	-----	--	--

<b>0.37 kW</b>	$n_1= 2790 \text{ min}^{-1}$	63C 2
	$n_1= 2790 \text{ min}^{-1}$	71A 2
	$n_1= 1380 \text{ min}^{-1}$	71B 4
	$n_1= 910 \text{ min}^{-1}$	80A 6

140	20	20	2.8	<b>UMI 50</b>	71A 2
140	20	19	1.5	<b>UMI 40</b>	71A 2
140	20	19	1.5	<b>UMI 40</b>	63C 2
138	10	21	3.5	<b>UMI 50</b>	71B 4
138	10	21	2.0	<b>UMI 40</b>	71B 4
92	15	31	2.5	<b>UMI 50</b>	71B 4
92	15	30	1.4	<b>UMI 40</b>	71B 4
61	15	46	5.7	<b>UMI 75</b>	80A 6
69	20	39	3.4	<b>UMI 63</b>	71B 4
69	20	39	1.9	<b>UMI 50</b>	71B 4
69	20	37	1.0	<b>UMI 40</b>	71B 4
49	28	51	2.7	<b>UMI 63</b>	71B 4
49	28	50	1.6	<b>UMI 50</b>	71B 4
49	28	48	0.9	<b>UMI 40</b>	71B 4
35	40	69	2.1	<b>UMI 63</b>	71B 4
45	20	60	3.9	<b>UMI 75</b>	80A 6
35	40	68	1.2	<b>UMI 50</b>	71B 4
33	28	76	3.7	<b>UMI 75</b>	80A 6
28	49	80	1.6	<b>UMI 63</b>	71B 4
28	49	79	0.9	<b>UMI 50</b>	71B 4
25	56	89	1.4	<b>UMI 63</b>	71B 4
25	56	86	0.8	<b>UMI 50</b>	71B 4
23	40	104	4.5	<b>UMI 90</b>	80A 6
23	40	104	2.4	<b>UMI 75</b>	80A 6
20	70	104	1.1	<b>UMI 63</b>	71B 4
19	49	122	3.5	<b>UMI 90</b>	80A 6
19	49	120	2.0	<b>UMI 75</b>	80A 6
17	80	113	1.0	<b>UMI 63</b>	71B 4
16	56	137	2.9	<b>UMI 90</b>	80A 6
16	56	135	1.6	<b>UMI 75</b>	80A 6
13	70	160	2.2	<b>UMI 90</b>	80A 6
13	70	155	1.4	<b>UMI 75</b>	80A 6
11	80	174	1.9	<b>UMI 90</b>	80A 6
11	80	171	1.2	<b>UMI 75</b>	80A 6
9	100	202	1.5	<b>UMI 90</b>	80A 6
9	100	198	0.9	<b>UMI 75</b>	80A 6

<b>0.55 kW</b>	$n_1= 2800 \text{ min}^{-1}$	71B 2
	$n_1= 1380 \text{ min}^{-1}$	71C 4
	$n_1= 1390 \text{ min}^{-1}$	80A 4
	$n_1= 910 \text{ min}^{-1}$	80B 6

572	5	7.9	3.4	<b>UMI 40</b>	71B 2
572	5	8.0	5.6	<b>UMI 50</b>	71B 2
400	7	11	4.5	<b>UMI 50</b>	71B 2
400	7	11	2.4	<b>UMI 40</b>	71B 2
286	5	15.8	4.1	<b>UMI 50</b>	80A 4
280	5	15.9	2.3	<b>UMI 40</b>	71C 4
280	5	16.1	4.0	<b>UMI 50</b>	71C 4
280	10	16	3.5	<b>UMI 50</b>	71B 2
280	10	16	2.0	<b>UMI 40</b>	71B 2
199	7	22	3.1	<b>UMI 50</b>	80A 4
197	7	22	3.0	<b>UMI 50</b>	71C 4
197	7	22	1.7	<b>UMI 40</b>	71C 4
187	15	23	1.4	<b>UMI 40</b>	71B 2
140	20	29	1.0	<b>UMI 40</b>	71B 2
139	10	32	7.0	<b>UMI 75</b>	80A 4
139	10	31	2.4	<b>UMI 50</b>	80A 4
138	10	31	2.3	<b>UMI 50</b>	71C 4

### 1.7 Gearmotors performances

$n_2$ min <sup>-1</sup>	ir	T2 Nm	FS'		
----------------------------	----	----------	-----	--	--

<b>0.55 kW</b>	$n_1= 2800 \text{ min}^{-1}$	71B 2
	$n_1= 1380 \text{ min}^{-1}$	71C 4
	$n_1= 1390 \text{ min}^{-1}$	80A 4
	$n_1= 910 \text{ min}^{-1}$	80B 6

138	10	31	1.4	<b>UMI 40</b>	71C 4
130	7	34	7.0	<b>UMI 75</b>	80B 6
130	7	34	2.4	<b>UMI 50</b>	80B 6
100	28	39	2.7	<b>UMI 63</b>	71B 2
100	28	39	1.6	<b>UMI 50</b>	71B 2
93	15	46	5.0	<b>UMI 75</b>	80A 4
93	15	45	2.9	<b>UMI 63</b>	80A 4
93	15	45	1.7	<b>UMI 50</b>	80A 4
92	15	46	1.7	<b>UMI 50</b>	71C 4
92	15	44	1.0	<b>UMI 40</b>	71C 4
70	20	60	3.7	<b>UMI 75</b>	80A 4
70	20	58	2.3	<b>UMI 63</b>	80A 4
70	20	57	1.3	<b>UMI 50</b>	80A 4
69	20	58	1.3	<b>UMI 50</b>	71C 4
61	15	69	6.3	<b>UMI 90</b>	80B 6
61	15	68.4	3.8	<b>UMI 75</b>	80B 6
50	28	78	5.3	<b>UMI 90</b>	80A 4
50	28	76	3.3	<b>UMI 75</b>	80A 4
50	28	75	1.8	<b>UMI 63</b>	80A 4
50	28	74	1.1	<b>UMI 50</b>	80A 4
49	28	76	1.8	<b>UMI 63</b>	71C 4
49	28	75	1.1	<b>UMI 50</b>	71C 4
46	20	90	4.9	<b>UMI 90</b>	80B 6
46	20	88	2.6	<b>UMI 75</b>	80B 6
46	20	87	1.8	<b>UMI 63</b>	80B 6
46	20	85	1.0	<b>UMI 50</b>	80B 6
35	40	107	3.8	<b>UMI 90</b>	80A 4
35	40	102	2.2	<b>UMI 75</b>	80A 4
35	40	101	1.4	<b>UMI 63</b>	80A 4
35	40	102	1.4	<b>UMI 63</b>	71C 4
35	40	100	0.8	<b>UMI 50</b>	71C 4
28	49	124	3.0	<b>UMI 90</b>	80A 4
28	49	120	1.8	<b>UMI 75</b>	80A 4
28	49	119	1.1	<b>UMI 63</b>	80A 4
28	49	119	1.0	<b>UMI 63</b>	71C 4
25	56	144	2.4	<b>UMI 90</b>	80A 4
25	56	138	1.5	<b>UMI 75</b>	80A 4
25	56	131	1.0	<b>UMI 63</b>	80A 4
25	56	132	1.0	<b>UMI 63</b>	71C 4
20	70	167	1.9	<b>UMI 90</b>	80A 4
20	70	161	1.2	<b>UMI 75</b>	80A 4
19	49	181	2.3	<b>UMI 90</b>	80B 6
19	49	178	1.4	<b>UMI 75</b>	80B 6
17	80	181	1.6	<b>UMI 90</b>	80A 4
17	80	178	1.0	<b>UMI 75</b>	80A 4
16	56	204	1.9	<b>UMI 90</b>	80B 6
16	56	200	1.0	<b>UMI 75</b>	80B 6
14	100	208	1.3	<b>UMI 90</b>	80A 4
14	100	208	0.8	<b>UMI 75</b>	80A 4
13	70	238	1.5	<b>UMI 90</b>	80B 6
13	70	230	0.9	<b>UMI 75</b>	80B 6
11	80	259	1.3	<b>UMI 90</b>	80B 6
11	80	254	0.8	<b>UMI 75</b>	80B 6
9	100	300	1.0	<b>UMI 90</b>	80B 6

### 1.7 Leistungen der Getriebemotoren

$n_2$ min <sup>-1</sup>	ir	T2 Nm	FS'		
----------------------------	----	----------	-----	--	--

<b>0.75 kW</b>	$n_1= 2820 \text{ min}^{-1}$	71C 2
	$n_1= 2820 \text{ min}^{-1}$	80A 2
	$n_1= 1390 \text{ min}^{-1}$	80B 4
	$n_1= 910 \text{ min}^{-1}$	80C 6
	$n_1= 920 \text{ min}^{-1}$	90S 6

572	5	10.9	4.1	<b>UMI 50</b>	80A 2
562	5	11	2.5	<b>UMI 40</b>	71C 2
562	5	11.1	4.0	<b>UMI 50</b>	71C 2
403	7	15	3.3	<b>UMI 50</b>	80A 2
400	7	15	3.3	<b>UMI 50</b>	71C 2
286	5	21.5	3.0	<b>UMI 50</b>	80B 4
282	10	21	2.6	<b>UMI 50</b>	80A 2
280	10	21	2.6	<b>UMI 50</b>	71C 2
199	7	31	6.7	<b>UMI 75</b>	80B 4
199	7	30	3.8	<b>UMI 63</b>	80B 4
199	7	30	2.2	<b>UMI 50</b>	80B 4
139	10	43	5.1	<b>UMI 75</b>	80B 4
139	10	43	2.9	<b>UMI 63</b>	80B 4
139	10	42	1.7	<b>UMI 50</b>	80B 4
131	7	46	5.1	<b>UMI 75</b>	90S 6
131	7	46	3.0	<b>UMI 63</b>	90S 6
101	28	55	3.4	<b>UMI 75</b>	80A 2
101	28	53	2.0	<b>UMI 63</b>	80A 2
101	28	53	1.2	<b>UMI 50</b>	80A 2
100	28	54	2.0	<b>UMI 63</b>	71C 2
100	28	53	1.2	<b>UMI 50</b>	71C 2
93	15	63	3.7	<b>UMI 75</b>	80B 4
93	15	62	2.1	<b>UMI 63</b>	80B 4
93	15	62	1.2	<b>UMI 50</b>	80B 4
70	20	82	4.6	<b>UMI 90</b>	80B 4
70	20	81	2.7	<b>UMI 75</b>	80B 4
70	20	79	1.7	<b>UMI 63</b>	80B 4
70	20	78	0.9	<b>UMI 50</b>	80B 4
50	28	107	3.9	<b>UMI 90</b>	80B 4
50	28	103	2.4	<b>UMI 75</b>	80B 4
50	28	102	1.3	<b>UMI 63</b>	80B 4
35	40	146	2.8	<b>UMI 90</b>	80B 4
35	40	139	1.6	<b>UMI 75</b>	80B 4
35	40	138	1.0	<b>UMI 63</b>	80B 4
28	49	169	2.2	<b>UMI 90</b>	80B 4
28	49	169	1.3	<b>UMI 75</b>	80B 4
25	56	196	1.8	<b>UMI 90</b>	80B 4
25	56	188	1.1	<b>UMI 75</b>	80B 4
23	40	211	2.2	<b>UMI 90</b>	80C 6
23	40	211	1.2	<b>UMI 75</b>	80C 6
20	70	227	1.4	<b>UMI 90</b>	80B 4
20	70	220	0.9	<b>UMI 75</b>	80B 4
19	49	247	1.7	<b>UMI 90</b>	80C 6
19	49	243	1.0	<b>UMI 75</b>	80C 6
17	80	247	1.2	<b>UMI 90</b>	80B 4
17	80	243	0.8	<b>UMI 75</b>	80B 4
16	56	279	1.9	<b>UMI 110</b>	90S 6
16	56	278	1.4	<b>UMI 90</b>	80C 6
16	56	273	0.8	<b>UMI 75</b>	80C 6
14	100	283	1.0	<b>UMI 90</b>	80B 4
13	70	327	1.7	<b>UMI 110</b>	90S 6
13	70	325	1.1	<b>UMI 90</b>	80C 6
11	80	361	1.5	<b>UMI 110</b>	90S 6
11	80	353	1.0	<b>UMI 90</b>	80C 6
9	100	409	0.7	<b>UMI 90</b>	80C 6

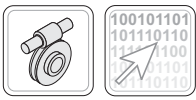

### 1.7 Prestazioni motoriduttori

$n_2$ min <sup>-1</sup>	ir	T2 Nm	FS'		
----------------------------	----	----------	-----	--	--

<b>0.88 kW</b>		$n_1 = 1350 \text{ min}^{-1}$	80C 4
----------------	--	-------------------------------	-------

282	5	25.6	2.5	<b>UMI 50</b>	80C 4
282	5	25.6	4.3	<b>UMI 63</b>	80C 4
193	7	37	5.5	<b>UMI 75</b>	80C 4
193	7	37	3.1	<b>UMI 63</b>	80C 4
193	7	37	1.9	<b>UMI 50</b>	80C 4
135	10	52	4.2	<b>UMI 75</b>	80C 4
135	10	52	2.4	<b>UMI 63</b>	80C 4
135	10	51	1.4	<b>UMI 50</b>	80C 4
90	15	75	3.0	<b>UMI 75</b>	80C 4
90	15	75	1.8	<b>UMI 63</b>	80C 4
90	15	75	1.0	<b>UMI 50</b>	80C 4
68	20	100	3.8	<b>UMI 90</b>	80C 4
68	20	98	2.2	<b>UMI 75</b>	80C 4
68	20	96	1.4	<b>UMI 63</b>	80C 4
48	28	129	3.2	<b>UMI 90</b>	80C 4
48	28	125	2.0	<b>UMI 75</b>	80C 4
48	28	124	1.1	<b>UMI 63</b>	80C 4
34	40	177	2.3	<b>UMI 90</b>	80C 4
34	40	168	1.3	<b>UMI 75</b>	80C 4
34	40	167	0.9	<b>UMI 63</b>	80C 4
28	49	204	1.1	<b>UMI 75</b>	80C 4
28	49	204	1.8	<b>UMI 90</b>	80C 4
24	56	227	0.9	<b>UMI 75</b>	80C 4
24	56	237	1.5	<b>UMI 90</b>	80C 4
19	70	266	0.7	<b>UMI 75</b>	80C 4
19	70	275	1.1	<b>UMI 90</b>	80C 4
17	80	299	1.0	<b>UMI 90</b>	80C 4
14	100	342	0.8	<b>UMI 90</b>	80C 4

<b>1.1 kW</b>		$n_1 = 2830 \text{ min}^{-1}$	80B 2
		$n_1 = 1390 \text{ min}^{-1}$	80D 4
		$n_1 = 1400 \text{ min}^{-1}$	90S 4
		$n_1 = 920 \text{ min}^{-1}$	90L 6

570	5	16.2	4.9	<b>UMI 63</b>	80B 2
570	5	16	2.8	<b>UMI 50</b>	80B 2
404	7	22	6.4	<b>UMI 75</b>	80B 2
404	7	22	3.8	<b>UMI 63</b>	80B 2
404	7	22	2.3	<b>UMI 50</b>	80B 2
286	5	31.6	3.5	<b>UMI 63</b>	90 S4
283	10	32	5.0	<b>UMI 75</b>	80B 2
283	10	31	3.0	<b>UMI 63</b>	80B 2
283	10	31	1.8	<b>UMI 50</b>	80B 2
280	5	32.3	3.4	<b>UMI 63</b>	80D 4
280	5	32.3	2.0	<b>UMI 50</b>	80D 4
200	7	45	4.6	<b>UMI 75</b>	90S 4
200	7	44	2.6	<b>UMI 63</b>	90S 4
199	7	45	4.6	<b>UMI 75</b>	80D 4
199	7	44	2.6	<b>UMI 63</b>	80D 4
189	15	46	3.7	<b>UMI 75</b>	80B 2
189	15	46	2.1	<b>UMI 63</b>	80B 2
189	15	46	1.3	<b>UMI 50</b>	80B 2
142	20	60	2.6	<b>UMI 75</b>	80B 2

N.B.  
Tutte le potenze indicate si riferiscono alla potenza meccanica dei riduttori.  
Per i riduttori contrassegnati con (\*) è opportuno effettuare la verifica della potenza limite termico secondo le indicazioni riportate nel par. 1.7-A

### 1.7 Gearmotors performances

$n_2$ min <sup>-1</sup>	ir	T2 Nm	FS'		
----------------------------	----	----------	-----	--	--

<b>1.1 kW</b>		$n_1 = 2830 \text{ min}^{-1}$	80B 2
		$n_1 = 1390 \text{ min}^{-1}$	80D 4
		$n_1 = 1400 \text{ min}^{-1}$	90S 4
		$n_1 = 920 \text{ min}^{-1}$	90L 6

142	20	59	1.0	<b>UMI 50*</b>	80B 2
140	10	63	3.5	<b>UMI 75</b>	80D 4
140	10	62	2.0	<b>UMI 63</b>	90S 4
139	10	64	5.4	<b>UMI 90</b>	80D 4
139	10	63	3.5	<b>UMI 75</b>	80D 4
139	10	63	2.0	<b>UMI 63</b>	80D 4
139	10	62	1.2	<b>UMI 50</b>	80D 4
131	7	68	5.6	<b>UMI 90</b>	90L 6
131	7	67	3.5	<b>UMI 75</b>	90L 6
131	7	67	2.0	<b>UMI 63</b>	90L 6
93	15	93	4.0	<b>UMI 90</b>	80D 4
93	15	91	2.5	<b>UMI 75</b>	80D 4
93	15	90	1.5	<b>UMI 63</b>	90S 4
93	15	91	1.4	<b>UMI 63</b>	80D 4
93	15	91	0.8	<b>UMI 50</b>	80D 4
70	20	121	3.2	<b>UMI 90</b>	80D 4
70	20	118	1.9	<b>UMI 75</b>	80D 4
70	20	116	1.2	<b>UMI 63</b>	90S 4
70	20	116	1.2	<b>UMI 63</b>	80D 4
61	15	137	3.2	<b>UMI 90</b>	90L 6
61	15	135	1.9	<b>UMI 75</b>	90L 6
61	15	134	1.1	<b>UMI 63</b>	90L 6
50	28	157	2.6	<b>UMI 90</b>	80D 4
50	28	150	1.6	<b>UMI 75</b>	80D 4
50	28	149	0.9	<b>UMI 63</b>	90S 4
50	28	150	0.9	<b>UMI 63</b>	80D 4
46	20	178	2.5	<b>UMI 90</b>	90L 6
46	20	172	1.3	<b>UMI 75</b>	90L 6
46	20	171	0.9	<b>UMI 63</b>	90L 6
35	40	216	3.0	<b>UMI 110</b>	90S 4
35	40	213	1.9	<b>UMI 90</b>	90S 4
29	49	254	2.3	<b>UMI 110</b>	90S 4
29	49	246	1.1	<b>UMI 90</b>	90S 4
29	49	234	1.0	<b>UMI 75</b>	90S 4
25	56	290	1.6	<b>UMI 110</b>	90S 4
25	56	286	1.2	<b>UMI 90</b>	90S 4
25	56	288	1.2	<b>UMI 90</b>	80D 4
23	40	306	0.8	<b>UMI 75</b>	90L 6
23	40	306	1.5	<b>UMI 90</b>	90L 6
20	70	336	1.4	<b>UMI 110</b>	90S 4
20	70	331	0.9	<b>UMI 90</b>	90S 4
20	70	333	0.9	<b>UMI 90</b>	80D 4
19	49	358	1.2	<b>UMI 90</b>	90L 6
18	80	360	0.8	<b>UMI 90</b>	90S 4
17	80	372	1.3	<b>UMI 110</b>	90S 4

NOTE.  
The indicated power is based on the mechanical capacities of the gearboxes.  
For the gearboxes marked with (\*) it is also necessary to obey the thermal capacity like shown on chapter 1.7-A.

### 1.7 Leistungen der Getriebemotoren

$n_2$ min <sup>-1</sup>	ir	T2 Nm	FS'		
----------------------------	----	----------	-----	--	--

<b>1.5 kW</b>		$n_1 = 2830 \text{ min}^{-1}$	80C 2
		$n_1 = 2830 \text{ min}^{-1}$	90S 2
		$n_1 = 1400 \text{ min}^{-1}$	90L 4
		$n_1 = 925 \text{ min}^{-1}$	90LB 6
		$n_1 = 940 \text{ min}^{-1}$	100A 6

576	5	21.9	3.6	<b>UMI 63</b>	90S 2
574	5	22	3.6	<b>UMI 63</b>	80C 2
574	5	21.7	2.0	<b>UMI 50</b>	80C 2
404	7	30	7.5	<b>UMI 90</b>	90S 2
404	7	31	4.7	<b>UMI 75</b>	90S 2
404	7	31	4.7	<b>UMI 75</b>	80C 2
404	7	30	2.8	<b>UMI 63</b>	90S 2
404	7	30	2.8	<b>UMI 63</b>	80C 2
286	5	43.1	2.5	<b>UMI 63</b>	90L 4
283	10	43	5.9	<b>UMI 90</b>	90S 2
283	10	43	3.7	<b>UMI 75</b>	90S 2
283	10	43	3.7	<b>UMI 75</b>	80C 2
283	10	43	2.2	<b>UMI 63</b>	90S 2
283	10	43	2.2	<b>UMI 63</b>	80C 2
200	7	62	5.2	<b>UMI 90</b>	90L 4
200	7	61	3.4	<b>UMI 75</b>	90L 4
200	7	60	1.9	<b>UMI 63</b>	90L 4
189	15	63	4.4	<b>UMI 90</b>	80C 2
189	15	62	2.7	<b>UMI 75</b>	90S 2
189	15	62	2.7	<b>UMI 75</b>	80C 2
189	15	62	1.6	<b>UMI 63</b>	90S 2
189	15	62	1.6	<b>UMI 63</b>	80C 2
140	10	87	4.0	<b>UMI 90</b>	90L 4
140	10	86	2.6	<b>UMI 75</b>	90L 4
140	10	85	1.5	<b>UMI 63</b>	90L 4
93	15	126	2.9	<b>UMI 90</b>	90L 4
93	15	124	1.9	<b>UMI 75</b>	90L 4
93	15	123	1.1	<b>UMI 63</b>	90L 4
70	20	164	2.3	<b>UMI 90</b>	90L 4
70	20	160	1.4	<b>UMI 75</b>	90L 4
70	20	158	0.9	<b>UMI 63</b>	90L 4
62	15	183	3.5	<b>UMI 110</b>	90LB 6
62	15	186	2.3	<b>UMI 90</b>	90LB 6
62	15	184	1.4	<b>UMI 75</b>	90LB 6
58	49	176	1.6	<b>UMI 90</b>	80C 2
58	49	176	1.6	<b>UMI 90</b>	90S 2
58	49	176	0.9	<b>UMI 75*</b>	80C 2
58	49	176	0.9	<b>UMI 75*</b>	90S 2
51	56	201	1.4	<b>UMI 90</b>	80C 2
51	56	201	1.4	<b>UMI 90</b>	90S 2
50	28	212	2.0	<b>UMI 90</b>	90L 4
50	28	212	1.2	<b>UMI 75</b>	90L 4
46	20	241	3.0	<b>UMI 110</b>	90LB 6
46	20	242	1.8	<b>UMI 90</b>	90LB 6
46	20	238	1.0	<b>UMI 75</b>	90LB 6
41	70	237	1.0	<b>UMI 90</b>	80C 2
41	70	237	1.0	<b>UMI 90</b>	90S 2
35	40	295	2.2	<b>UMI 110</b>	90L 4
35	40	291	1.4	<b>UMI 90</b>	90L 4
35	40	287	0.8	<b>UMI 75*</b>	90L 4
29	49	346	1.7	<b>UMI 110</b>	90L 4
29	49	336	1.1	<b>UMI 90</b>	90L 4
25	56	395	1.2	<b>UMI 110</b>	90L 4

HINWEIS.  
Die Leistungsangaben beziehen sich auf die mechanische Belastbarkeit der Getriebe.  
Bei den mit (\*) gekennzeichneten Getrieben ist außerdem die thermische Leistungsgrenze zu beachten (s. Kap. 1.7-A).



1.7 Prestazioni motoriduttori

$n_2$ min <sup>-1</sup>	ir	T2 Nm	FS'		
----------------------------	----	----------	-----	--	--

<b>1.5 kW</b>			$n_1= 2830 \text{ min}^{-1}$ $n_1= 2830 \text{ min}^{-1}$ $n_1= 1400 \text{ min}^{-1}$ $n_1= 925 \text{ min}^{-1}$ $n_1= 940 \text{ min}^{-1}$	80C 2 90S 2 90L 4 90LB 6 100A 6
---------------	--	--	------------------------------------------------------------------------------------------------------------------------------------------------------------	---------------------------------------------

25	56	390	0,9	<b>UMI 90</b>	90L 4
24	40	408	1,1	<b>UMI 90</b>	100A 6
23	40	415	1,1	<b>UMI 90</b>	90LB 6
20	70	458	1,1	<b>UMI 110</b>	90L 4
19	49	478	0,9	<b>UMI 90</b>	100A 6
19	49	486	0,9	<b>UMI 90</b>	90LB 6
18	80	508	1,0	<b>UMI 110</b>	90L 4
17	56	546	1,0	<b>UMI 110</b>	100A 6
17	56	555	1,0	<b>UMI 110</b>	90LB 6
13	70	640	0,9	<b>UMI 110</b>	100A 6
13	70	650	0,8	<b>UMI 110</b>	90LB 6

<b>1.8 kW</b>			$n_1= 2770 \text{ min}^{-1}$ $n_1= 1400 \text{ min}^{-1}$ $n_1= 940 \text{ min}^{-1}$	80D 2 90LB 4 100B 6
---------------	--	--	---------------------------------------------------------------------------------------------	---------------------------

560	5	27	2,9	<b>UMI 63</b>	80D 2
560	5	26,7	1,7	<b>UMI 50*</b>	80D 2
396	7	37	6,2	<b>UMI 90</b>	80D 2
396	7	37	3,8	<b>UMI 75</b>	80D 2
396	7	37	2,2	<b>UMI 63</b>	80D 2
396	7	37	1,4	<b>UMI 50*</b>	80D 2
286	5	51,7	2,1	<b>UMI 63</b>	90LB 4
277	10	53	4,8	<b>UMI 90</b>	80D 2
277	10	52	3,0	<b>UMI 75</b>	80D 2
277	10	52	1,8	<b>UMI 63</b>	80D 2
277	10	52	1,1	<b>UMI 50*</b>	80D 2
200	7	74	4,3	<b>UMI 90</b>	90LB 4
200	7	73	2,8	<b>UMI 75</b>	90LB 4
200	7	72	1,6	<b>UMI 63</b>	90LB 4
185	15	77	3,6	<b>UMI 90</b>	80D 2
185	15	76	2,2	<b>UMI 75</b>	80D 2
185	15	76	1,3	<b>UMI 63*</b>	80D 2
140	10	104	3,3	<b>UMI 90</b>	90LB 4
140	10	103	2,1	<b>UMI 75</b>	90LB 4
140	10	102	1,2	<b>UMI 63</b>	90LB 4
93	15	151	2,5	<b>UMI 90</b>	90LB 4
93	15	148	1,5	<b>UMI 75</b>	90LB 4
93	15	147	0,9	<b>UMI 63*</b>	90LB 4
70	20	196	1,9	<b>UMI 90</b>	90LB 4
70	20	194	1,1	<b>UMI 75</b>	90LB 4
63	15	219	2,9	<b>UMI 110</b>	100B 6
63	15	219	2	<b>UMI 90</b>	100B 6
57	49	216	1,3	<b>UMI 90</b>	80D 2
57	49	216	0,8	<b>UMI 75*</b>	80D 2
50	28	254	1,6	<b>UMI 90</b>	90LB 4
50	28	254	1,0	<b>UMI 75*</b>	90LB 4
49	56	247	1,1	<b>UMI 90*</b>	80D 2
47	20	289	2,5	<b>UMI 110</b>	100B 6
47	20	289	1,6	<b>UMI 90</b>	100B 6
40	70	291	0,8	<b>UMI 90*</b>	80D 2
35	40	354	1,8	<b>UMI 110</b>	90LB 4
35	40	349	1,2	<b>UMI 90</b>	90LB 4
29	49	415	1,4	<b>UMI 110</b>	90LB 4
29	49	403	0,9	<b>UMI 90*</b>	90LB 4
25	56	474	1,0	<b>UMI 110</b>	90LB 4
20	70	550	0,9	<b>UMI 110</b>	90LB 4
18	80	609	0,8	<b>UMI 110</b>	90LB 4

1.7 Gearmotors performances

$n_2$ min <sup>-1</sup>	ir	T2 Nm	FS'		
----------------------------	----	----------	-----	--	--

<b>2.2 kW</b>			$n_1= 2840 \text{ min}^{-1}$ $n_1= 1410 \text{ min}^{-1}$ $n_1= 950 \text{ min}^{-1}$	90L 2 100A 4 112A 6
---------------	--	--	---------------------------------------------------------------------------------------------	---------------------------

570	5	32,4	3,4	<b>UMI 63</b>	90L 2
406	7	45	5,2	<b>UMI 90</b>	90L 2
406	7	45	3,2	<b>UMI 75</b>	90L 2
406	7	45	1,9	<b>UMI 63*</b>	90L 2
284	10	63	4,1	<b>UMI 90</b>	90L 2
284	10	63	2,5	<b>UMI 75</b>	90L 2
284	10	62	1,5	<b>UMI 63*</b>	90L 2
189	15	92	3,0	<b>UMI 90</b>	90L 2
189	15	91	1,8	<b>UMI 75</b>	90L 2
189	15	91	1,1	<b>UMI 63*</b>	90L 2
141	10	127	2,7	<b>UMI 90</b>	100A 4
141	10	125	1,8	<b>UMI 75</b>	100A4
101	28	159	1,2	<b>UMI 75*</b>	90L2
396	7	37	6,2	<b>UMI 90</b>	80D 2
396	7	37	3,8	<b>UMI 75</b>	80D 2
277	10	53	4,8	<b>UMI 90</b>	80D 2
277	10	53	3,0	<b>UMI 75</b>	80D 2
200	7	74	4,3	<b>UMI 90</b>	90LB 4
200	7	73	2,8	<b>UMI 75</b>	90LB 4
141	10	127	2,7	<b>UMI 90</b>	100A 4
101	28	157	2,0	<b>UMI 90</b>	90L 2
101	28	159	1,2	<b>UMI 75*</b>	90L 2
94	15	183	2,9	<b>UMI 110</b>	100A 4
94	15	183	2,0	<b>UMI 90</b>	100A 4
94	15	181	1,3	<b>UMI 75</b>	100A 4
71	20	241	2,6	<b>UMI 90</b>	100A 4
71	20	238	1,6	<b>UMI 90</b>	100A 4
71	20	235	0,9	<b>UMI 75*</b>	100A 4
63	15	268	1,6	<b>UMI 90</b>	100BL 6
63	15	265	1,0	<b>UMI 75*</b>	100BL 6
58	49	261	1,7	<b>UMI 110</b>	90L 2
50	28	313	1,8	<b>UMI 110</b>	100A 4
50	28	309	1,3	<b>UMI 90</b>	100A 4
50	28	309	0,8	<b>UMI 75*</b>	100A 4
35	40	429	1,5	<b>UMI 110</b>	100A 4
35	40	423	1,0	<b>UMI 90</b>	100A 4
35	40	417	0,6	<b>UMI 75</b>	100A 4
29	49	504	1,2	<b>UMI 110</b>	100A 4
29	49	489	0,8	<b>UMI 90</b>	100A 4
25	56	576	0,8	<b>UMI 110</b>	100A 4

1.7 Leistungen der Getriebemotoren

$n_2$ min <sup>-1</sup>	ir	T2 Nm	FS'		
----------------------------	----	----------	-----	--	--

<b>3 kW</b>			$n_1= 2840 \text{ min}^{-1}$ $n_1= 2860 \text{ min}^{-1}$ $n_1= 1420 \text{ min}^{-1}$ $n_1= 940 \text{ min}^{-1}$ $n_1= 950 \text{ min}^{-1}$	90LB 2 100A 2 100B 4 112B 6 132S 6
-------------	--	--	------------------------------------------------------------------------------------------------------------------------------------------------------------	------------------------------------------------

576	5	43,8	1,8	<b>UMI 63*</b>	90LB 2
409	7	60	3,8	<b>UMI 90</b>	100A 2
406	7	61	2,3	<b>UMI 75*</b>	90LB 2
406	7	61	1,4	<b>UMI 63*</b>	90LB 2
284	10	86	3,0	<b>UMI 90</b>	90LB 2
284	10	86	1,8	<b>UMI 75*</b>	90LB 2
284	10	85	1,1	<b>UMI 63*</b>	90LB 2
203	7	121	2,6	<b>UMI 90</b>	100B 4
203	7	120	1,7	<b>UMI 75*</b>	100B 4
191	15	125	3,2	<b>UMI 110</b>	100A 2
189	15	126	2,2	<b>UMI 90</b>	90LB 2
189	15	124	1,3	<b>UMI 75*</b>	90LB 2
189	15	124	0,8	<b>UMI 63*</b>	90LB 2
142	10	171	3,1	<b>UMI 110</b>	100B 4
142	10	171	2,0	<b>UMI 90</b>	100B 4
142	10	169	1,3	<b>UMI 75*</b>	100B 4
134	7	181	2,1	<b>UMI 90</b>	112B 6
134	7	179	1,3	<b>UMI 75*</b>	112B 6
102	28	213	1,5	<b>UMI 90*</b>	100A 2
102	28	216	0,9	<b>UMI 75*</b>	100A 2
101	28	215	1,5	<b>UMI 90*</b>	90LB 2
101	28	217	0,9	<b>UMI 75*</b>	90LB 2
95	15	248	2,2	<b>UMI 110</b>	100B 4
95	15	248	1,5	<b>UMI 90</b>	100B 4
95	15	245	0,9	<b>UMI 75*</b>	100B 4
94	10	256	1,6	<b>UMI 90</b>	112B 6
94	10	253	1,0	<b>UMI 75*</b>	112B 6
72	40	293	1,1	<b>UMI 90*</b>	100A 2
71	20	327	1,9	<b>UMI 110</b>	100B 4
71	40	295	1,1	<b>UMI 90*</b>	90LB 2
71	20	323	1,2	<b>UMI 90</b>	100B 4
63	15	632	1,7	<b>UMI 110</b>	132S 6
63	15	366	1,2	<b>UMI 90*</b>	112B 6
58	49	349	0,8	<b>UMI 90*</b>	100A 2
58	49	351	0,8	<b>UMI 90*</b>	90LB 2
51	28	424	1,3	<b>UMI 110</b>	100B 4
47	20	482	1,5	<b>UMI 110</b>	112B 6
36	40	581	1,1	<b>UMI 110</b>	100B 4
29	49	682	0,9	<b>UMI 110</b>	100B 4





### 1.7 Prestazioni motoriduttori

$n_2$ min <sup>-1</sup>	ir	T2 Nm	FS'		
----------------------------	----	----------	-----	--	--

<b>4 kW</b>	$n_1 = 2860 \text{ min}^{-1}$	100B 2
	$n_1 = 2860 \text{ min}^{-1}$	112A 2
	$n_1 = 1410 \text{ min}^{-1}$	100BL 4
	$n_1 = 1425 \text{ min}^{-1}$	112A 4
	$n_1 = 950 \text{ min}^{-1}$	132M 6

409	7	80	4.2	UMI 110	112A 2
409	7	80	4.2	UMI 110	100A 2
409	7	80	2,9	UMI 90	100B 2
409	7	80	2,9	UMI 90	112A 2
409	7	80	1,8	UMI 75*	100B 2
409	7	80	1,8	UMI 75*	112A 2
286	10	114	3.4	UMI 110	112A 2
286	10	114	3.4	UMI 110	100B 2
286	10	114	2,2	UMI 90*	100B 2
286	10	114	2,2	UMI 90*	112A 2
286	10	114	1,4	UMI 75*	100B 2
286	10	114	1,4	UMI 75*	112A 2
204	7	161	3.0	UMI 110	112A 4
204	7	161	2,0	UMI 90	112A 4
204	7	160	1,3	UMI 75*	112A 4
201	7	163	2,0	UMI 90	100BL 4
201	7	161	1,3	UMI 75*	100BL 4
191	15	166	2.4	UMI 110	112A 2
191	15	166	2.4	UMI 110	100B 2
191	15	166	1,7	UMI 90*	100B 2
191	15	166	1,7	UMI 90*	112A 2
191	15	164	1,0	UMI 75*	100B 2
191	15	164	1,0	UMI 75*	112A 2
143	10	228	2.4	UMI 110	112A 4
143	20	219	1,3	UMI 90*	100B 2
143	20	219	1,3	UMI 90*	112A 2
143	10	228	1,5	UMI 90*	112A 4
143	10	225	1,0	UMI 75*	112A 4
141	10	230	1,5	UMI 90*	100BL 4
141	10	228	1,0	UMI 75*	100BL 4
136	7	239	2.4	UMI 110	132M 6
102	28	284	1,1	UMI 90*	100B 2
102	28	284	1,1	UMI 90*	112A 2
95	15	330	1.6	UMI 110	112A 4
95	15	330	1,1	UMI 90*	112A 4
94	15	333	1,1	UMI 90*	100BL 4
72	40	390	0,8	UMI 90*	100B 2
72	40	390	0,8	UMI 90*	112A 2
71	20	434	1.4	UMI 110	112A 4
71	20	429	0,9	UMI 90*	112A 4
71	20	433	0,9	UMI 90*	100BL 4
63	15	483	1.3	UMI 110	132M 6
51	28	563	1.0	UMI 110*	112A 4
36	40	772	0.8	UMI 110*	112A 4

### 1.7 Gearmotors performances

$n_2$ min <sup>-1</sup>	ir	T2 Nm	FS'		
----------------------------	----	----------	-----	--	--

<b>5.5 kW</b>	$n_1 = 2880 \text{ min}^{-1}$	112B 2
	$n_1 = 2870 \text{ min}^{-1}$	132S 2
	$n_1 = 1440 \text{ min}^{-1}$	132S 4
	$n_1 = 1400 \text{ min}^{-1}$	112BL 4
	$n_1 = 950 \text{ min}^{-1}$	132ML 6

411	7	110	3.1	UMI 110	112B 2
410	7	110	3.1	UMI 110	132S 2
411	7	110	2,1	UMI 90*	112B 2
411	7	110	1,3	UMI 75*	112B 2
288	10	156	2.5	UMI 110	112B 2
287	10	156	2.5	UMI 110	132S 2
288	10	155	1,6	UMI 90*	112B 2
288	10	155	1,0	UMI 75*	112B 2
200	7	226	1,4	UMI 90*	112BL 4
200	7	223	0,9	UMI 75*	112BL 4
192	15	227	1,7	UMI 110*	112B 2
192	15	227	1,2	UMI 90*	112B 2
191	15	228	1,7	UMI 110*	132S 2
144	10	310	1,7	UMI 110	132S 4
144	20	299	1,0	UMI 90*	112B 2
140	10	319	1,1	UMI 90*	112BL 4
136	7	329	1,8	UMI 110	132ML 6
103	28	388	0,8	UMI 90*	112B 2
96	15	449	1,2	UMI 110*	132S 4
93	15	461	1,15	UMI 110*	112BL 4
93	15	461	0,8	UMI 90*	112BL 4
63	15	663	1.0	UMI 110*	132ML 6

<b>7.5 kW</b>	$n_1 = 2890 \text{ min}^{-1}$	132SL 2
	$n_1 = 2860 \text{ min}^{-1}$	112BL 2
	$n_1 = 1440 \text{ min}^{-1}$	132M 4

413	7	149	2.3	UMI 110*	132SL 2
409	7	151	2.3	UMI 110*	112BL 2
409	7	151	1,5	UMI 90*	112BL 2
409	7	151	0,9	UMI 75*	112BL 2
289	10	211	1,9	UMI 110*	132SL 2
286	10	213	1,8	UMI 110*	112BL 2
286	10	213	1,2	UMI 90*	112BL 2
206	7	299	1,6	UMI 110*	132M 4
193	15	309	1,3	UMI 110*	132SL 2
191	15	312	1,3	UMI 110*	112BL 2
191	15	312	0,9	UMI 90*	112BL 2
96	15	612	0,9	UMI 110*	132M 4

<b>9.2 kW</b>	$n_1 = 1450 \text{ min}^{-1}$	132ML 4
		4

207	7	365	1.3	UMI 110*	132ML 4
145	10	515	1.0	UMI 110*	132ML 4

### 1.7 Leistungen der Getriebemotoren

$n_2$ min <sup>-1</sup>	ir	T2 Nm	FS'		
----------------------------	----	----------	-----	--	--

<b>11 kW</b>	$n_1 = 2940 \text{ min}^{-1}$	132M 2
	$n_1 = 1455 \text{ min}^{-1}$	160M 4
	$n_1 = 965 \text{ min}^{-1}$	160L 6

420	7	215	1.6	UMI 110*	132M 2
294	10	304	1.3	UMI 110*	132M 2

N.B.  
Tutte le potenze indicate si riferiscono alla potenza meccanica dei riduttori.

Per i riduttori contrassegnati con (\*) è opportuno effettuare la verifica della potenza limite termico secondo le indicazioni riportate nel par. 1.7-A

NOTE.  
The indicated power is based on the mechanical capacities of the gearboxes.

For the gearboxes marked with (\*) it is also necessary to obey the thermal capacity like shown on chapter 1.7-A.

HINWEIS.  
Die Leistungsangaben beziehen sich auf die mechanische Belasbarkeit der Getriebe.

Bei den mit (\*) gekennzeichneten Getrieben ist außerdem die thermische Leistungsgrenze zu beachten (s. Kap. 1.7-A).





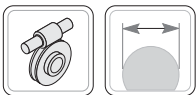

1.8 Dimensioni

1.8 Dimensions

1.8 Abmessungen

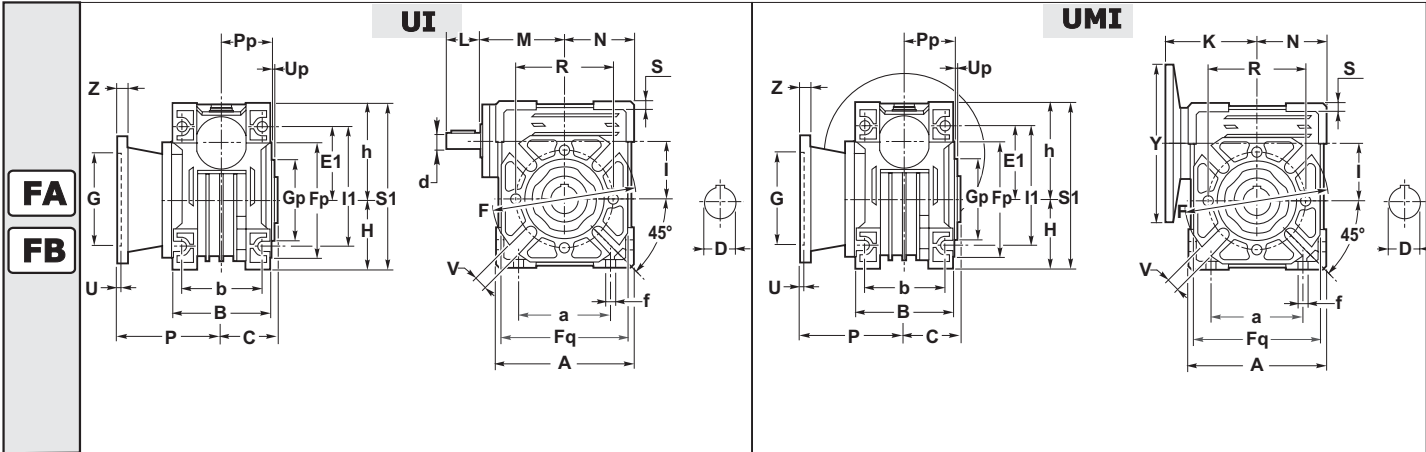
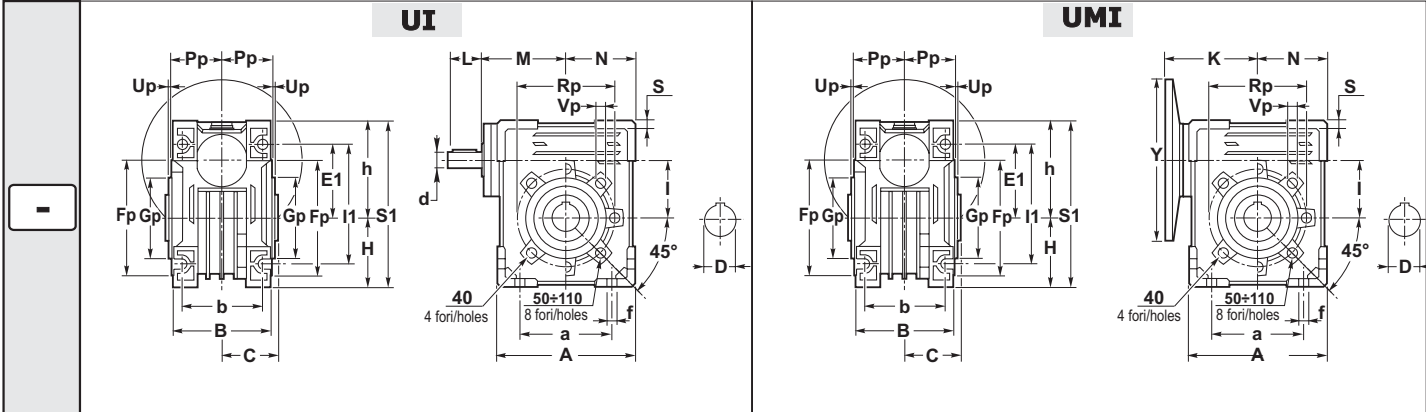
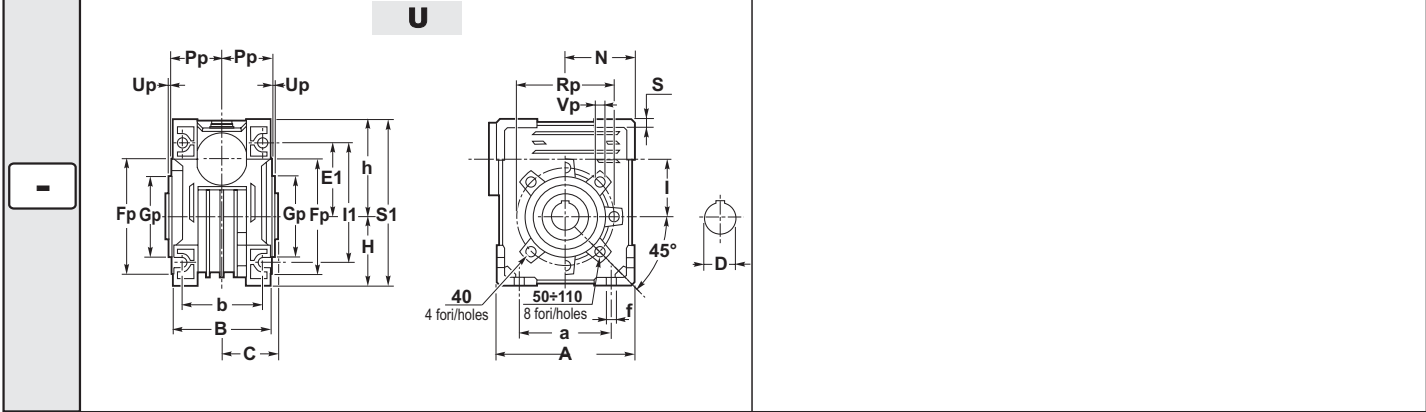



1.8 Dimensioni

1.8 Dimensions

1.8 Abmessungen

	A	a	B	b	C	D <sub>H7</sub>	d <sub>i6</sub>	E1	f	h	H	I	I1	L	M	m	N	S	S1
40	100	70	71	60	39	18	11	55	6.5	71.5	50	40	90	22	64	M5	50	6	121.5
50	120	80	85	70	46	25	14	64	8.5	84	60	50	104	30	74	M6	60	7	144
63	144	100	103	85	56	25	18	80	8.5	102	72	63	130	45	96	M6	72	8	174
75	172	120	112	90	60	28 (30)	24	93	11.5	119	86	75	153	50	105	M8	86	10	205
90	206	140	130	100	70	35	24	102	13	135	103	90	172	50	125	M8	103	11	238
110	255	170	144	115	77.5	42	28	125	14	167.5	127.5	110	207 <sup>0</sup> <sub>+3</sub>	60	142	M8	127.5	14.5	295

	Fp	Gp (e8)	Pp	Rp	Up	Vp
40	87	60	36.5	75	2.5	M6
50	100	70	43.5	85	2.5	M8
63	110	80	53	95	3	M8
75	140	95	57	115	3	M8
90	160	110	67	130	3	M10
110	200	130	74	165	3.5	M10

		F	Fq	G (F8)	P	R	U	V	Z
40	FA	110	95	60	67	75	4	9	7
	FB		95		97				
50	FA	125	110	70	90	85	5	11	9
	FB		110		120				
63	FA	180	142	115	82	150	6	11	10
	FB		142		112				
75	FA	200	170	130	111	165	6	14	13
	FB	160	160	110	90	130	5	11	12
90	FA	210	200	152	111	175	6	14	13
	FB	250	210	180	122	215	6	14	16
110	FA	280	260	170	131	230	6	14	16

UMI - Versione Entrata / Input version / Antriebsausführung							
UMI		40	50	63	75	90	110
IEC	Y	K	K	K	K	K	K
56 B5	120	70.5	-	-	-	-	-
56 B14	80	-	-	-	-	-	-
63 B5	140	70.5	80.5	-	-	-	-
63B14	90	70.5•	80.5•	-	-	-	-
71 B5	160	70.5	80.5	95	-	-	-
71B14	105	70.5	80.5•	95•	-	-	-
80 B5	200	-	80.5	95	118	128	-
80 B14	120	-	80.5	95	118•	128	-
90 B5	200	-	-	95	118	128	152
90 B14	140	-	-	95	120	128	153
100-112 B5	250	-	-	-	120	130	152
100-112 B14	160	-	-	-	120	130	153
132 B5	300	-	-	-	-	-	152.5

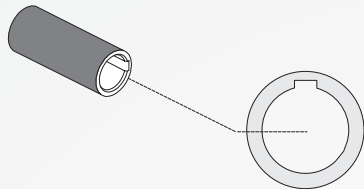
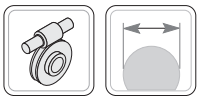

C21

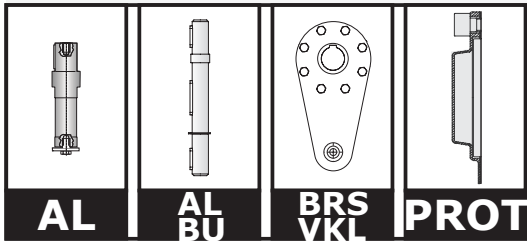

C22

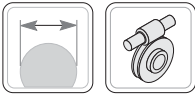

1.8.1 - ALBERI LENTI

1.8.1 - OUTPUT SHAFT

1.8.1 - ABTRIEBSWELLEN

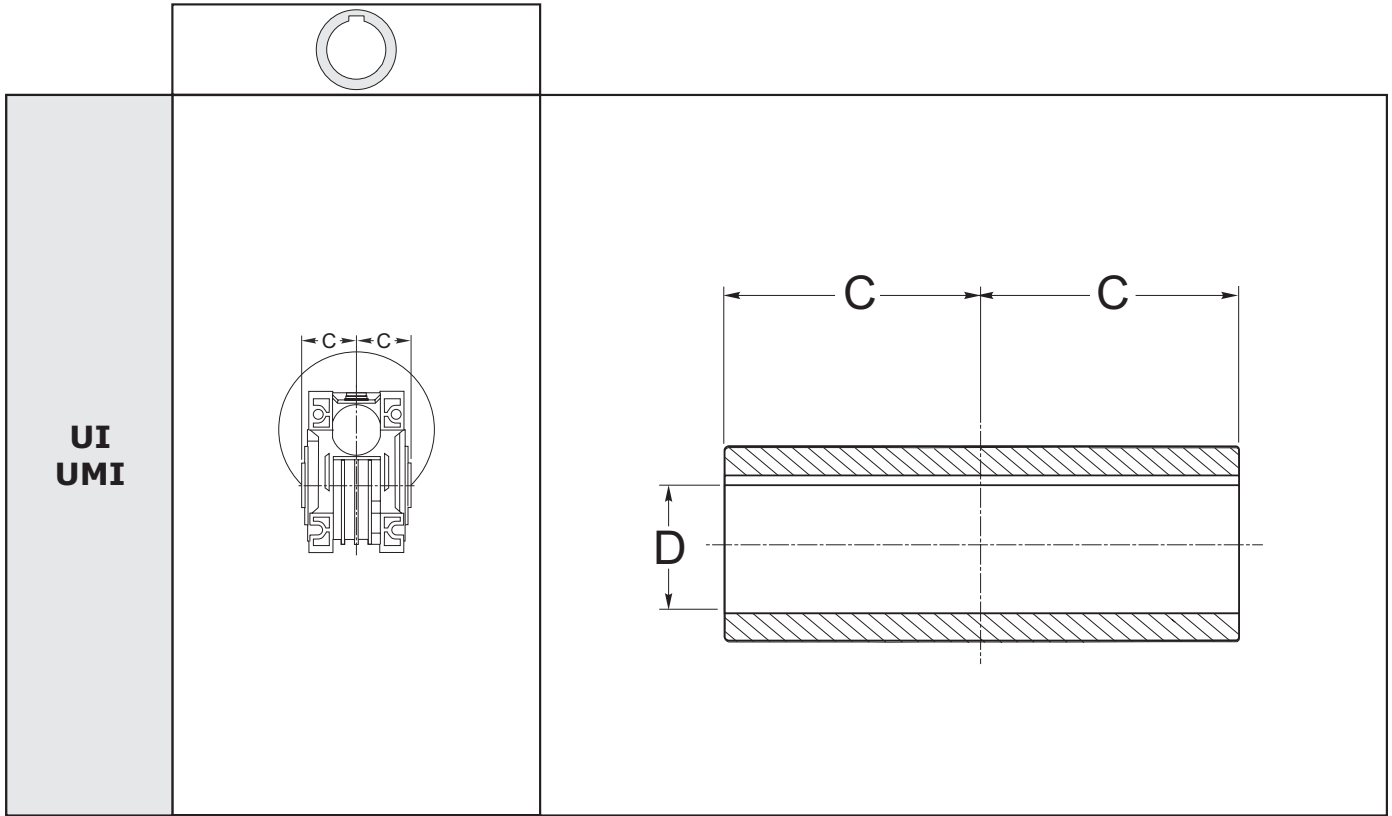

	40	50	63	75		90	110
<b>D</b>	18	25	25	28	(30)	35	42
<b>tolerance D</b>	H7	H7	H7	H7	H7	H7	H7
<b>C</b>	39	46	56	60	H7	70	77,5

Perno macchina / Customer shaft / Maschinachse

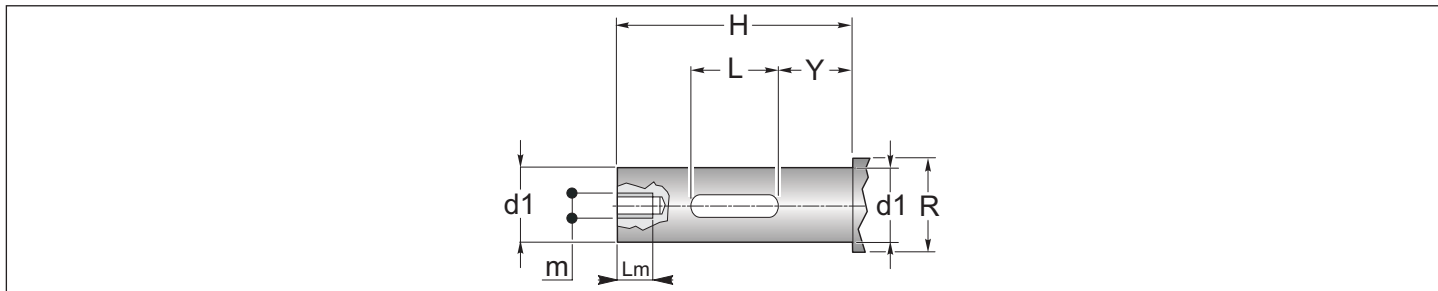

	40	50	63	75		90	110
<b>d1</b>	18	25	25	28	(30)	35	42
<b>tolerance d1</b>	g6	g6	g6	g6	g6	g6	g6
<b>H</b>	76	89	109	117	117	137	153
<b>L</b>	40	50	60	60	60	70	80
<b>m</b>	M8	M8	M8	M8	M8	M10	M10
<b>Lm</b>	16	16	16	16	16	25	25
<b>R</b>	22	28	34	34	36	38	50
<b>Y</b>	21	24	30	30	30	37	37

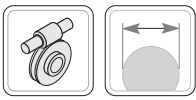

1.9 OPT - ACC. - Accessori - Opzioni

1.9 OPT - ACC. - Accessories - Options

1.9 OPT-ACC.Zubehör -Optionen

**AL** AL - ALBERO LENTO SPORGENTE  
AL - SINGLE OUTPUT SHAFTS  
AL - EINSEITIGE ABTRIEBSWELLEN

**AL BU** AL\_BU - ALBERO LENTO BISPORGENTE  
AL\_BU - DOUBLE OUTPUT SHAFTS  
AL\_BU - BEIDSEITIGE ABTRIEBSWELLEN

Tutti i riduttori a vite senza fine sono forniti con albero lento cavo.  
A richiesta, possono essere forniti alberi lenti come indicato nei disegni dimensionali.  
Le dimensioni delle linguette sono conformi alle norme UNI 6604-69.

All worm gearboxes are supplied with hollow output shaft. Output shafts as shown in the size drawings can be supplied upon request.  
Sizes of feathers comply with standards UNI 6604-69.

Alle Schneckengetriebe werden mit hohler Abtriebswelle geliefert. Auf Anfrage können Abtriebswellen gemäß den Maßzeichnungen geliefert werden.  
Die Abmessungen der Federn entsprechen den Normen UNI 6604-69.

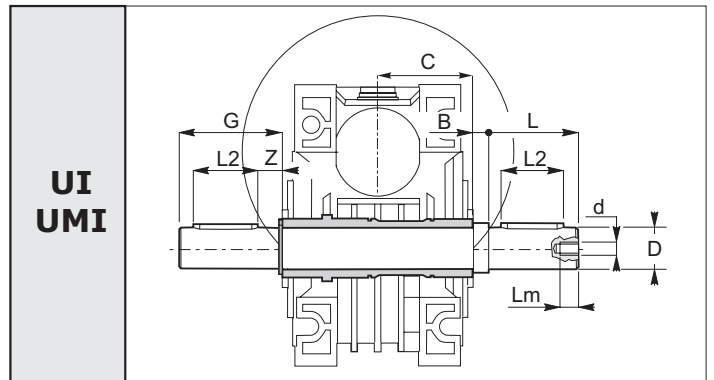
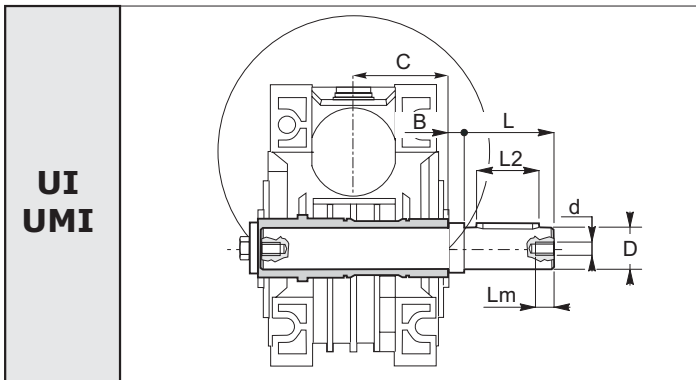
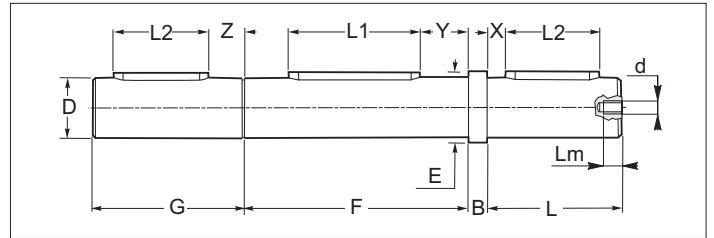
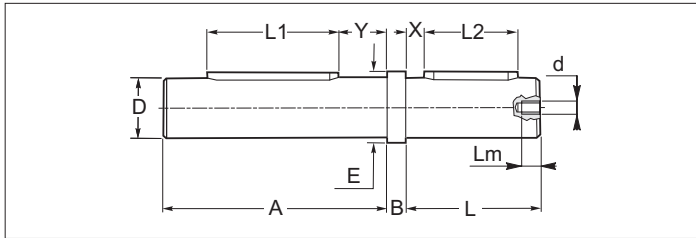

	UI - UMI					
	40	50	63	75	90	110
<b>A</b>	76	89	109	117	137	153
<b>B</b>	10	10	10	10	10	10
<b>C</b>	39	46	56	60	70	77,5
<b>D</b>	18	25	25	28	35	42
<b>tolerance D</b>	g6	g6	g6	g6	g6	g6
<b>d</b>	M8	M8	M8	M8	M10	M10
<b>E</b>	22	28	34	34	38	50
<b>F</b>	78	92	112	120	140	155
<b>G</b>	50	55	70	70	90	110
<b>L</b>	40	45	60	60	80	100
<b>L1</b>	40	50	60	60	70	80
<b>L2</b>	25	30	40	40	50	80
<b>Lm</b>	16	16	16	16	25	25
<b>X</b>	8	7.5	10	10	15	10
<b>Y</b>	21	24	30	30	37	37
<b>Z</b>	18	18	20	20	25	20

**ATTENZIONE**  
L'albero lento sporgente è fornito per essere installato sulla versione del riduttore con albero **CAVO** con diametro **STANDARD**.

**ATTENTION**  
The output shaft is available only for standard hollow shaft diameter.

**Achtung:**  
Die Einseitige Abtriebswelle wird fuer die Montage bei Getrieben mit Standart Hohlwelle geliefert.

**N.B.**  
Tutti gli alberi lenti vengono forniti in kit di montaggio completi di linguette, rondelle, viti (e anelli elastici seeger per l'albero bisporgente)

**NOTE**  
All output shafts are supplied in kit complete with feathers, washers and screws (as well as snap rings for the double extended shaft).

**HINWEIS**  
Alle Abtriebswellen werden als Bausätze komplett mit Federn, Scheiben und Schrauben geliefert (bei der beidseitigen Abtriebswelle auch die Seegerringe).

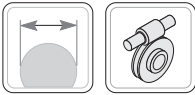

1.9 OPT - ACC. - Accessori - Opzioni

1.9 OPT - ACC. - Accessories - Options

1.9 OPT-ACC.Zubehör -Optionen

**BRS VKL** BRS\_VKL - Braccio Reazione Semplice\_con boccola\_VKL  
 BRS\_VKL - Torque arm - Single\_with VKL\_bushing  
 BRS\_VKL - Drehmomentstütze - Normal\_mit VKL - Buchse

Per il fissaggio del riduttore mediante tirante, viene fornito in allegato l'apposito braccio di reazione.

*If the gearbox shall be shaft mounted as an extra part there is also available a torque arm.*

Soll das Getriebe pendelnd gelagert werden, so ist als Zubehörteil auch eine Drehmomentstütze.

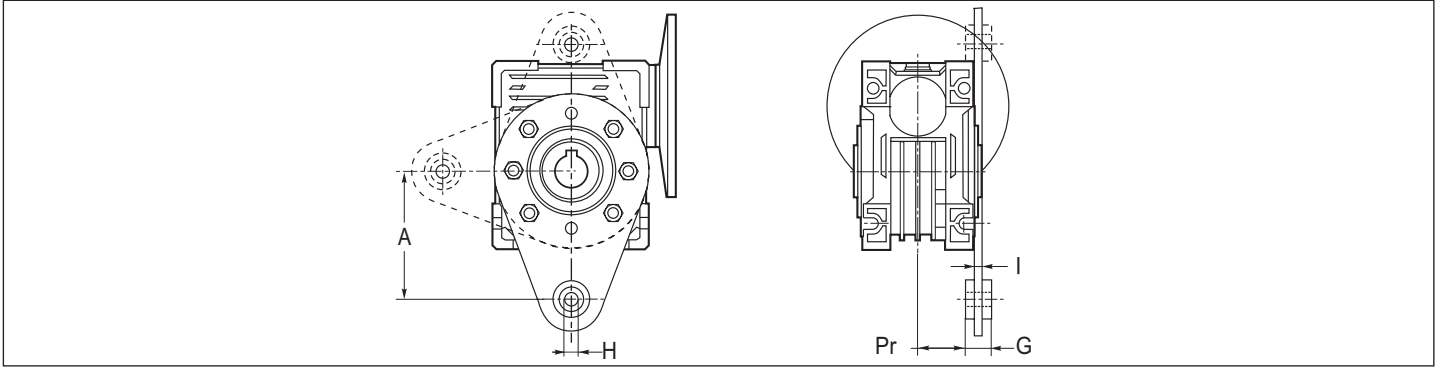

UI - UMI	40	50	63	75	90	110
A	100	100	150	200	200	250
G	15	15	20	25	25	25
H	10	10	10	20	20	20
I	4	4	6	6	6	6
Pr	31	38	46	47.5	57.5	64.5

**PROT** PROT. - Coperchio di protezione

**PROT. - Protection cover**

**PROT - Schutzeinrichtungendeckel**

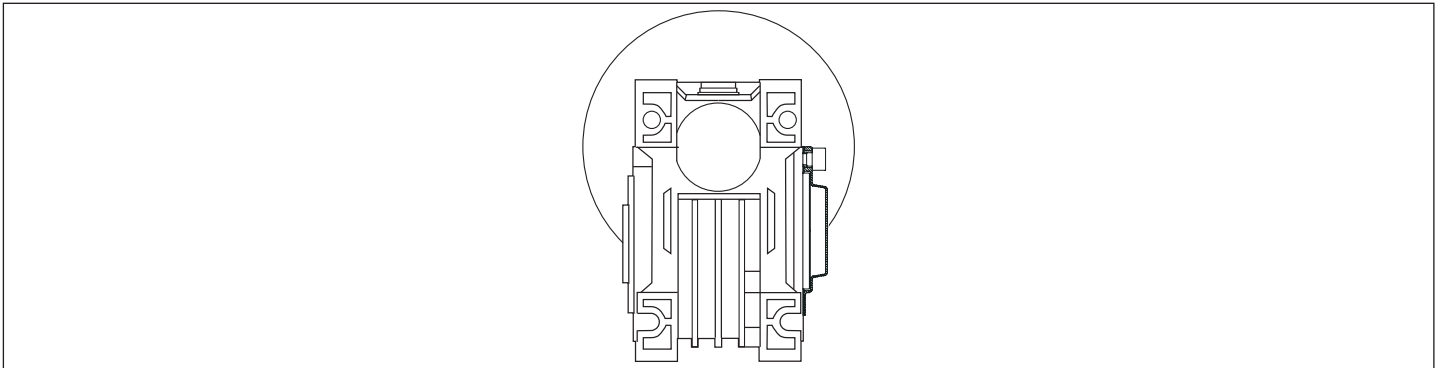

**ELSX** ELSX - Vite senza fine - Elica Sinistra

**ELSX - Worm Geraboxe - Left helix**

**ELSX - Linksgängige Schraubenlinie der Schnecke**

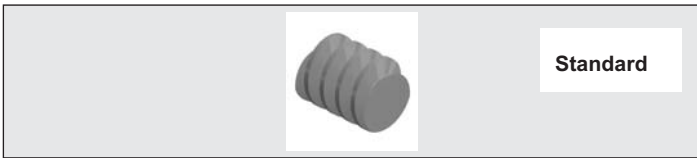

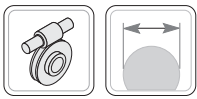

1.10 Linguette

1.10 Keys

1.10 Paßfedern

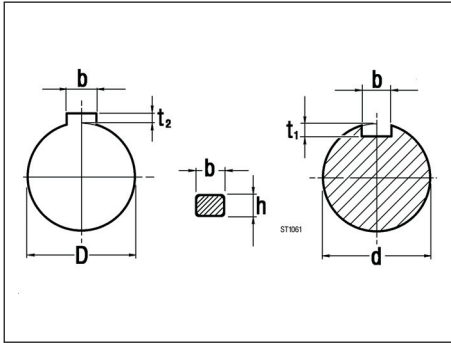

Albero entrata  
Input shaft  
Antriebswelle

d	b x h	t <sub>1</sub>	
9	3 x 3	1.8	
11	4 x 4	2.5	
14	5 x 5	3.0	+0.1 0
18	6 x 6	3.5	
19	6 x 6	3.5	
24	8 x 7	4.0	
28	8 x 7	4.0	
30	8 x 7	4.0	
35	10 x 8	5.0	
38	10 x 8	5.0	+0.2 0
42	12 x 8	5.0	
48	14 x 9	5.5	
55	16 x 10	6.0	
65	18 x 11	7.0	

Albero uscita  
Output shaft  
Abtriebswelle

D	b x h	t <sub>2</sub>	
11	4 x 4	1.8	
14	5 x 5	2.3	
18	6 x 6	2.8	+0.1 0
19	6 x 6	2.8	
24	8 x 7	3.3	
25	8 x 7	3.3	
28	8 x 7	3.3	
30	8 x 7	3.3	
32	10 x 8	3.3	
35	10 x 8	3.3	
40	10 x 8	3.3	
42	12 x 8	3.3	
48	14 x 9	3.8	
50	14 x 9	3.8	+0.2 0
55	16 x 10	4.3	
60	18 x 11	4.3	
65	18 x 11	4.4	
70	20 x 12	4.9	
80	22 x 14	5.4	
90	25 x 14	5.4	
100	28 x 16	6.4	
110	28 x 16	6.4	