

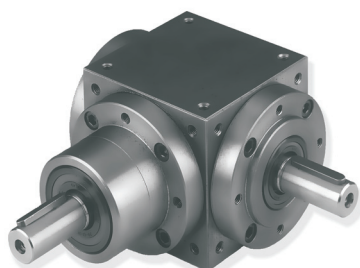

1.0 RINVII ANGOLARI Z
1.0 RIGHT ANGLE Z
1.0 WINKELGETRIEBE Z

Z

1.1	Caratteristiche tecniche	<i>Technical characteristics</i>	Technische Eigenschaften	E1
1.2	Designazione	<i>Designation</i>	Bezeichnungen	E2
1.3	Versioni	<i>Versions</i>	Ausführungen	E2
1.4	Lubrificazione	<i>Lubrication</i>	Schmierung	E5
1.5	Carichi radiali e assiali	<i>Axial and overhung loads</i>	Radiale und Axiale Belastungen	E6
1.6	Coppia massima trasmissibile per accoppiamenti in serie	<i>Maximum torque to be transmittable through in sequence connections</i>	Das hoeste drehmoment erlaubt durch Serien - verbindungen	E7
1.7	Prestazioni rinvii angolari	<i>Gearmotors performances</i>	Leistungen der Getriebe	E8
1.8	Dimensioni	<i>Dimensions</i>	Abmessungen	E12
1.9	Accessori	<i>Accessories</i>	Zubehör	E34



1.1 Caratteristiche tecniche

Il prodotto si distingue per il favorevole rapporto potenza/ingombro e per la possibilità di funzionamento silenzioso e regolare anche a velocità elevate. Carcassa monoblocco in ghisa lavorata su tutte le facce, ingranaggi Gleason e cuscinetti largamente dimensionati. Il disegno modulare dei ns rinvii angolari Z permette di equipaggiare il gruppo con alberi supplementari, fino ad un massimo di 6 (tranne che per il rapporto 1/1). Tutte queste caratteristiche rendono il ns prodotto ai vertici della categoria.

1.1 Technical characteristics

Our right angle gears make the difference for the favourable relation between power/dimension and for the possibility of a silent and regular functioning also at high speed. One body piece in cast iron with all the external faces machined, the gears are Gleason and the bearings are overrated as well. The modular construction of our Z right angle gears permits us to mount up to six input/output shafts (except ratio 1/1). All these features place our products on top of this sector

1.1 Technische Eigenschaften

Unsere Winkelgetriebe zeichnen sich durch das positive Verhältnis von Leistung und Platzbedarf und durch einen ruhigen und reibungslosen Betrieb selbst bei hohen Geschwindigkeiten aus. Monoblockgehäuse mit allseitig bearbeiteten Außenflächen, großzügig dimensionierten Gleason-Zahnradern und Lagern. Der modulare Aufbau erlaubt die Montage von bis zu sechs Wellen (Ausnahme ist das Verhältnis 1/1). Diese Eigenschaften machen dieses Produkt zu einem der führenden am Markt.

1.2 Designazione

1.2 Designation

1.2 Bezeichnung

Grandezza Size Größe	Versione Versions Ausführung	ir	IEC (B5)	Flangia uscita Output flange Abtriebsflansch	Entrata supplementare Additional input Zusatzantrieb
Z 12 19 24 32 38 42 55 75	A-AS-AD-AP C-DR-B-BS BD-AH-BH AX-DX*	1-1.5-2-3-4-5		FC 1 FC 2 FC 3 FP 1 FP 2 FP 3	A 90-A 180-A 270 AS 90-AS 180-AS 270 AD 90-AD 180-AD 270 C 90 DR 90 AH 90-AH 180-AH 270
	MA-MAS-MAD MC-MDR-MB MBS-MBD MAH-MBH	1-1.5-2-3-4-5	63 160		(non applicabili con ir =1)

Esempio / Example / Beispiel

Z19 A 1.5 FC 1 A 90



Z19 MA 1.5 PAM 80 FC 1



* Versione moltiplicatore / Multiplier version / Ausführung übersetzungsgetriebe

Altre specifiche:

Posizione della morsettiera del motore se diversa da quella standard (1).
Posizione di montaggio con indicazione tappi di livello e carico; se non specificato si considera standard la posizione M1.

Further specifications:

Terminal board box position if different from standard (1).
Mounting position. Indications must be given regarding level and breather plugs. If not specified positions, M1 is considered standard.

Weitere Spezifikationen:

Stellung des Klemmenkastens des Motors, falls diese von der Standard-Ausführung abweicht (1).
Montagestellung mit Angabe der Ölpegel und Entlüfterstöpsel. Falls nichts anderes angegeben wird, gilt die Pos. M1 als Standard.

1.3 Versioni

1.3 Versions

1.3 Ausführung

Grandezze / Sizes / Größe: 12-19-24-32-38-42-55-75, i = 1-1.5-2-3-4-5

A

MA

A90

A180

A270

Grandezze / Sizes / Größe: 12-19-24-32-38-42-55-75, i = 1-1.5-2-3-4-5

AS

MAS

AS90

AS180

AS270

1.3 Versioni

1.3 Versions

1.3 Ausführung

Grandezze / Sizes / Größe: 12-19-24-32-38-42-55-75, i = 1-1.5-2-3-4-5

AD **MAD** **AD90** **AD180** **AD270**

Grandezze / Sizes / Größe: 19-24-32-38-42-55-75, i = 1.5-2
Versione moltiplicatore / Multiplier version / Ausführung übersetzungsgetriebe

AX

Grandezze / Sizes / Größe: 12-19-24-32-38-42-55-75, i = 1-1.5-2-3-4-5

AP

Grandezze / Sizes / Größe: 12-19-24-32-38-42-55-75, i = 1-1.5-2-3-4-5

C **MC** **C90**

Grandezze / Sizes / Größe: 12-19-24-32-38-42-55-75, i = 1-1.5-2-3-4-5
Due Alberi Uscita / Two Shafts Output / Zwei Abtriebswelle

DR **MDR** **DR90** **DR180** **DR270**



1.3 Versioni

1.3 Versions

1.3 Ausführung

Grandezze / Sizes / Größe: **12-19-24-32-38-42-55-75**, **i = 1-1.5-2-3-4-5**
Due Alberi Uscita / Two Shafts Output / Zwei Abtriebswelle
Versione moltiplicatore / Multiplier version / Ausführung übersetzungsgetriebe

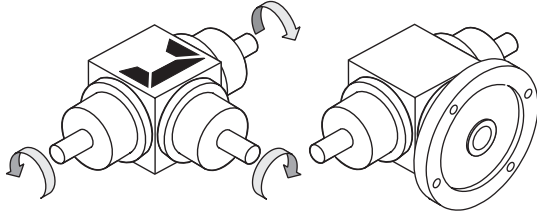

DX

MDX

Grandezze / Sizes / Größe: **12-19-24-32-38-42-55-75** **i = 1-1.5-2-3-4-5**
Due Alberi Entrata / Two Shafts Input / Zwei Antriebswelle

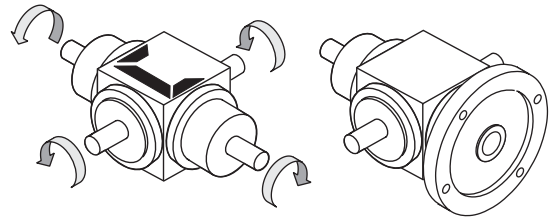

B

MB

Grandezze / Sizes / Größe: **12-19-24-32-38-42-55-75**, **i = 1-1.5-2-3-4-5**
Due Alberi Entrata / Two Shafts Input / Zwei Antriebswelle

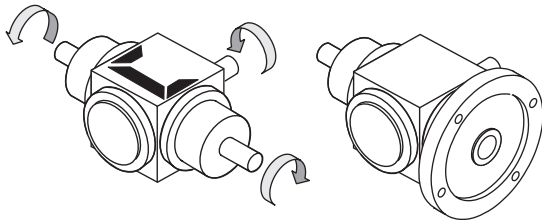

BS

MBS

Grandezze / Sizes / Größe: **12-19-24-32-38-42-55-75**, **i = 1-1.5-2-3-4-5**
Due Alberi Entrata / Two Shafts Input / Zwei Antriebswelle

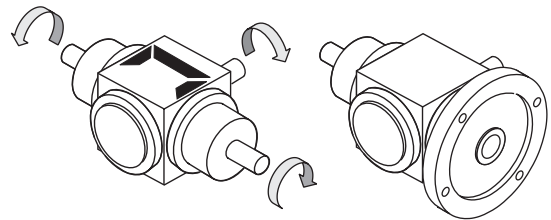

BD

MBD

Grandezze / Sizes / Größe: **12-19-24-32-38-42-55-75**, **i = 1-1.5-2-3-4-5**

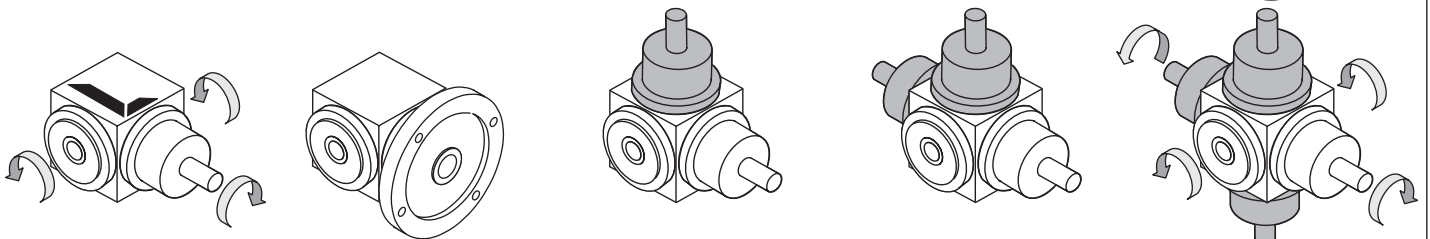

AH

MAH

AH90

AH180

AH270

Grandezze / Sizes / Größe: **12-19-24-32-38-42-55-75**, **i = 1-1.5-2-3-4-5**
Due Alberi Entrata / Two Shafts Input / Zwei Antriebswelle

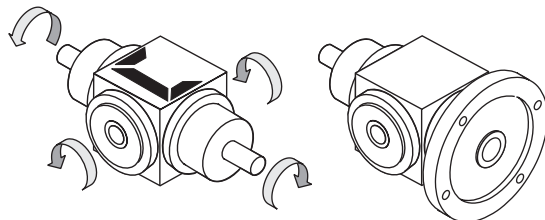

BH

MBH

1- STANDARD

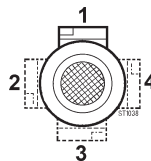

Posizione morsetteria
Terminal board position
Lage des Klemmenkastens

1.4 Lubrificazione

1.4 Lubrication

1.4 Schmierung

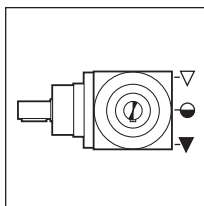

M1

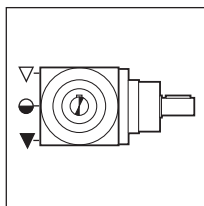

M2

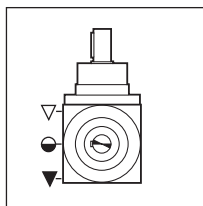

M3

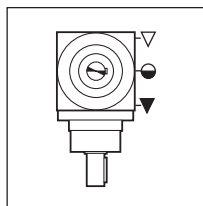

M4

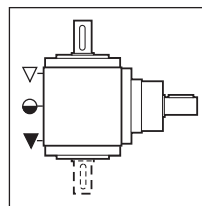

M6

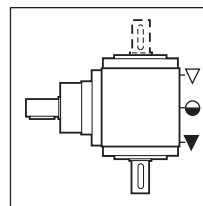

M5

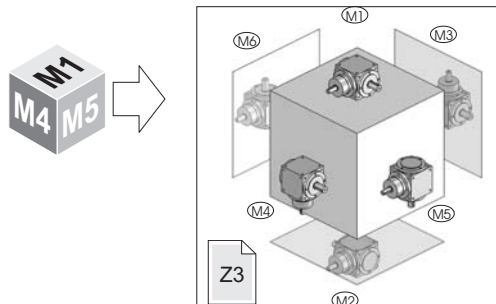

- ▽ Carico / Breather plug / Nachfüllen - Entlüftung
- Livello / Level plug / Pegel
- ▼ Scarico / Drain plug / Auslauf

ZA							
Quantità di lubrificante - Lubricant Quantity - Schmiermittelmenge - [Kg]							
12	19	24	32	38	42	55	75
0.1	0.15	0.22	0.60	1.1	2.2	3.6	9.0

! Solo per ZA.
Per Ulteriori informazioni Contattare il ns. servizio tecnico

! Only ZA.
Contact our technical dept

! Gültig nur für ZA.
Wenden Sie sich an unseren technischen Service

Nota: Se in fase d'ordine la posizione di montaggio è omessa, il riduttore verrà fornito con i tappi predisposti per la posizione M1.

Note: If the mounting position is not specified in the order, the worm gearbox supplied will have plugs pre-arranged for position M1.

Anmerkung: Sollte in der Auftragsphase die Einbaulage nicht angegeben werden, wird das Getriebe mit Stopfen für die Einbaulage M1.

Eventuali forniture con predisposizioni tappi diverse da quella indicata in tabella, dovranno essere concordate.

The supply of gearboxes with different plug pre-arrangements has to be agreed with the manufacturer.

Lieferungen, die eine Auslegung hinsichtlich der Stopfen aufweisen, die von den Angaben in der Tabelle abweichen, müssen vorab vereinbart werden.



1.5 Carichi radiali e assiali

Le trasmissioni effettuate tramite pignoni per catena, ruote dentate o pulegge generano delle forze radiali (F_r) sugli alberi dei riduttori.

I valori dei carichi radiali e assiali generati dall'applicazione debbono essere sempre minori o uguali a quelli ammissibili indicati nelle tabelle.

Carichi radiali

Tab. 4.2

i	F_{r1} [N]							
	Z.							
	12	19	24	32	38	42	55	75
1-2-3	550	850	1400	2000	4000	6000	10000	25000
4-5	—	600	850	1400	2000	4000	6000	10000

i	F_{r2} [N]							
	Z.							
	12	19	24	32	38	42	55	75
Tutti /All/ Alle	900	1500	2200	3500	7000	10000	15000	35000

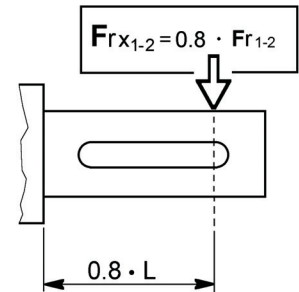
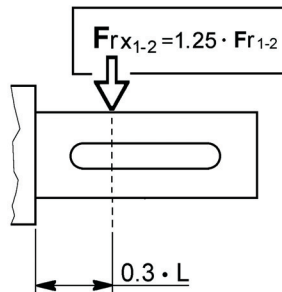
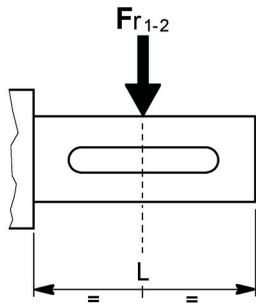

I carichi radiali indicati nelle tabelle si intendono applicati a metà della sporgenza dell'albero standard e sono riferiti ai riduttori operanti con fattore di servizio 1. Per i carichi non agenti sulla mezzeria dell'albero lento o veloce si ha:

- a 0.3 della sporgenza:
 $F_{rx} = 1.25 \times F_{r1-2}$
- a 0.8 dalla sporgenza:
 $F_{rx} = 0.8 \times F_{r1-2}$

The radial loads shown in the tables are applied on the centre line of the standard shaft extension and are related to gearboxes working with service factor 1. For loads which are not applied on the centre line of the output or input shaft, following values will be obtained:

- at 0.3 from extension:
 $F_{rx} = 1.25 \times F_{r1-2}$
- at 0.8 from extension:
 $F_{rx} = 0.8 \times F_{r1-2}$

Bei den in der Tabelle angegebenen Radialbelastungen wird eine Kräfteinwirkung auf die Mitte des Wellenendes zugrunde gelegt; außerdem arbeiten die Getriebe mit Betriebsfaktor 1.

Bei Lasten, die nicht auf die Mitte der Ab- und Antriebswellen wirken, legt man folgende Werte zugrunde:

- 0.3 vom Wellenabsatz entfernt:
 $F_{rx} = 1.25 \times F_{r1-2}$
- 0.8 vom Wellenabsatz entfernt:
 $F_{rx} = 0.8 \times F_{r1-2}$

Carichi assiali

Axial loads

Axial Belastungen

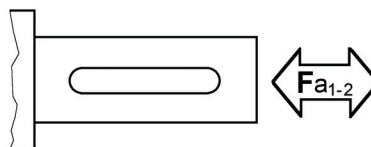



Carichi assiali

Axial loads

Axial Belastungen

Tab. 4.3

i	F _{a1} [N]							
	Z.							
	12	19	24	32	38	42	55	75
	Cuscinetti a sfere (escluso versione AP)							
1-2-3	300	450	700	1100	1700	2700	5000	10000
4-5	—	400	450	700	1100	1700	2700	5000
	Cuscinetti a rulli conici (solo versione AP)							
1-2-3	—	650	1000	1500	2400	4000	7800	16000
4-5	—	450	650	1000	1500	2400	4000	7800

i	F _{a2} [N]							
	Z.							
	12	19	24	32	38	42	55	75
	Cuscinetti a sfere (escluso versione AP)							
Tutti /All Alle	500	700	1300	1700	3400	4800	6800	15000
	Cuscinetti a rulli conici (solo versione AP)							
Tutti /All Alle	—	1000	1800	2500	5000	7000	10000	22000

1.6 Coppia massima trasmissibile per accoppiamenti in serie

1.6 Maximum torque to be transmittable through in sequence connections

1.6 Das hoeeste drehmoment erlaubt durch Serien - verbindungen

Quando più rinvii angolari, di forma A oppure AH, vengono montati in serie occorre sempre verificare che la coppia massima necessaria sia compatibile con quella indicata in tabella.

When many A and AH right angle gearboxes are mounted in sequence it is necessary to verify the compatibility between the maximum needed couple and those indicated in the following chart.

Wenn mehrere Winkelgetrieben A oder AH typ, in Serie verdunden sind, muss man pruefen, dass hoechste gebrauchte Drehmoment mit dem in folgender Tabelle.

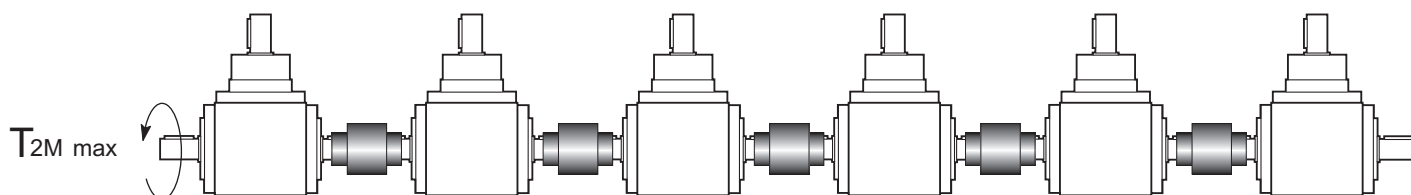

Tab. 4.4

	Z.						
	19 A 19 AH	24 A 24 AH	32 A 32 AH	38 A 38 AH	42 A 42 AH	55 A 55 AH	75 A 75 AH
T _{2M} max (Nm)	60	120	300	500	700	1600	4000

Se invece le condizioni di lavoro sono superiori a quelle sopra indicate occorre utilizzare rinvii angolari di forma AP con albero passante di dimensioni maggiori, le cui coppie massime sono:

On the other hand, if the working conditions are more severe than those above mentioned you will have to use AP right angle gear boxes with connection shaft bigger than the above mentioned. The transmittable highest torque are:

Falls dass die Arbeitsbedingungen schwerer als die o.g. sind, muss man AP Winkelgetrieben (mit groesseren Verbindungswellen) benutzen. Hier folgt die Tabelle mit en Hoechsten Drehmomenten.

Tab. 4.5

	Z.						
	19 AP	24 AP	32 AP	38 AP	42 AP	55 AP	75 AP
T _{2M} max (Nm)	120	300	500	700	1000	3000	6500



1.7 Prestazioni rinvii angolari Z

1.7 Z gearboxes performances

1.7 Leistungen der Z-Getriebe

Z 12 (A-AS-AD-AP-C-DR-B-BD-BS)

2.5

ir	$n_1 = 2800 \text{ min}^{-1}$				$n_1 = 1400 \text{ min}^{-1}$				$n_1 = 900 \text{ min}^{-1}$				$n_1 = 500 \text{ min}^{-1}$				IEC
	n_2 min ⁻¹	T _{2M} Nm	P kW	RD %	n_2 min ⁻¹	T _{2M} Nm	P kW	RD %	n_2 min ⁻¹	T _{2M} Nm	P kW	RD %	n_2 min ⁻¹	T _{2M} Nm	P kW	RD %	
1	2800	13.1	4.0	95	1400	14.9	2.3	95	900	16.2	1.6	95	500	18.7	1.0	95	71 (B14) 63 (B5)
1.5	—	—	—	—	—	—	—	—	—	—	—	—	—	—	—	—	
2	1400	13.7	2.1	95	700	14.9	1.1	95	450	16.2	0.80	95	250	18.7	0.52	95	
3	933	7.5	0.77	95	467	8.9	0.46	95	300	9.7	0.32	95	167	11.1	0.20	95	
4	—	—	—	—	—	—	—	—	—	—	—	—	—	—	—	—	
5	—	—	—	—	—	—	—	—	—	—	—	—	—	—	—	—	—

Z 12 (DX) Versione moltiplicatore / Multiplier version / Ausführung übersetzungsgetriebe

2.5

ir	$n_1 = 1400 \text{ min}^{-1}$				$n_1 = 900 \text{ min}^{-1}$				$n_1 = 500 \text{ min}^{-1}$				IEC	
	n_2 min ⁻¹	T _{2M} Nm	P kW	RD %	n_2 min ⁻¹	T _{2M} Nm	P kW	RD %	n_2 min ⁻¹	T _{2M} Nm	P kW	RD %		
1.5	—	—	—	—	—	—	—	—	—	—	—	—	—	—
2	2800	7.5	2.3	95	1800	8.1	1.6	95	1000	9.4	1.0	95		

Z 19 (A-AS-AD-AP-C-DR-B-BD-BS-AH-BH)

6.0

ir	$n_1 = 2800 \text{ min}^{-1}$				$n_1 = 1400 \text{ min}^{-1}$				$n_1 = 900 \text{ min}^{-1}$				$n_1 = 500 \text{ min}^{-1}$				IEC
	n_2 min ⁻¹	T _{2M} Nm	P kW	RD %	n_2 min ⁻¹	T _{2M} Nm	P kW	RD %	n_2 min ⁻¹	T _{2M} Nm	P kW	RD %	n_2 min ⁻¹	T _{2M} Nm	P kW	RD %	
1	2800	69	21	95	1400	73	11.3	95	900	75	7.4	95	500	76	4.2	95	71 (B5) 63 (B5)
1.5	1867	47	9.7	95	933	49	5.0	95	600	50	3.3	95	333	51	1.9	95	
2	1400	55	8.5	95	700	57	4.4	95	450	59	2.9	95	250	60	1.7	95	
3	933	31	3.2	95	467	32	1.6	95	300	32	1.1	95	167	33	0.61	95	
4	700	35	2.7	95	350	28	1.1	95	225	28	0.7	95	125	29	0.40	95	
5	560	28	1.7	95	280	29	0.90	95	180	29	0.6	95	100	30	0.33	95	

Z 19 (AX-DX) Versione moltiplicatore / Multiplier version / Ausführung übersetzungsgetriebe

6.0

ir	$n_1 = 1400 \text{ min}^{-1}$				$n_1 = 900 \text{ min}^{-1}$				$n_1 = 500 \text{ min}^{-1}$				IEC
	n_2 min ⁻¹	T _{2M} Nm	P kW	RD %	n_2 min ⁻¹	T _{2M} Nm	P kW	RD %	n_2 min ⁻¹	T _{2M} Nm	P kW	RD %	
1.5	2100	25	5.7	95	1350	25	3.7	95	750	26	2.1	95	—
2	2800	29	8.8	95	1800	30	5.9	95	1000	30	3.3	95	

Z 24 (A-AS-AD-AP-C-DR-B-BD-BS-AH-BH)

12.0

ir	$n_1 = 2800 \text{ min}^{-1}$				$n_1 = 1400 \text{ min}^{-1}$				$n_1 = 900 \text{ min}^{-1}$				$n_1 = 500 \text{ min}^{-1}$				IEC
	n_2 min ⁻¹	T _{2M} Nm	P kW	RD %	n_2 min ⁻¹	T _{2M} Nm	P kW	RD %	n_2 min ⁻¹	T _{2M} Nm	P kW	RD %	n_2 min ⁻¹	T _{2M} Nm	P kW	RD %	
1	2800	76	23	95	1400	82	12.7	95	900	86	8.5	95	500	90	4.9	95	90 (B5) 80 (B5) 71 (B5)
1.5	1867	78	16.0	95	933	81	8.3	95	600	83	5.5	95	333	85	3.1	95	
2	1400	69	10.7	95	700	72	5.6	95	450	74	3.6	95	250	75	2.1	95	
3	933	45	4.6	95	467	47	2.4	95	300	48	1.6	95	167	49	0.89	95	
4	700	66	5.1	95	350	69	2.6	95	225	70	1.7	95	125	71	1.0	95	
5	560	57	3.5	95	280	61	1.9	95	180	62	1.2	95	100	64	0.71	95	80 (B5) 71 (B5)

Z 24 (AX-DX) Versione moltiplicatore / Multiplier version / Ausführung übersetzungsgetriebe

12.0

ir	$n_1 = 1400 \text{ min}^{-1}$				$n_1 = 900 \text{ min}^{-1}$				$n_1 = 500 \text{ min}^{-1}$				IEC
	n_2 min ⁻¹	T _{2M} Nm	P kW	RD %	n_2 min ⁻¹	T _{2M} Nm	P kW	RD %	n_2 min ⁻¹	T _{2M} Nm	P kW	RD %	
1.5	2100	40	9.4	95	1350	42	6.2	95	750	43	3.5	95	—
2	2800	36	11.2	95	1800	37	7.3	95	1000	38	4.1	95	

1.7 Prestazioni rinvii angolari Z

1.7 Z gearboxes performances

1.7 Leistungen der Z-Getriebe

Z 32 (A-AS-AD-AP-C-DR-B-BD-BS-AH-BH)																	22
ir	$n_1 = 2800 \text{ min}^{-1}$				$n_1 = 1400 \text{ min}^{-1}$				$n_1 = 900 \text{ min}^{-1}$				$n_1 = 500 \text{ min}^{-1}$				IEC
	n_2 min ⁻¹	T_{2M} Nm	P kW	RD %	n_2 min ⁻¹	T_{2M} Nm	P kW	RD %	n_2 min ⁻¹	T_{2M} Nm	P kW	RD %	n_2 min ⁻¹	T_{2M} Nm	P kW	RD %	
1	2800	173	54	95	1400	187	29	95	900	195	19.3	95	500	203	11.2	95	112 (B5) 100 (B5) 90 (B5) 80 (B5)
1.5	1867	150	31	95	933	163	16.7	95	600	159	10.5	95	333	178	6.5	95	
2	1400	132	20	95	700	140	10.8	95	450	142	7.1	95	250	147	4.1	95	
3	933	94	9.6	95	467	105	5.4	95	300	107	3.5	95	167	111	2.0	95	
4	700	92	7.1	95	350	100	3.9	95	225	101	2.5	95	125	104	1.4	95	
5	560	75	4.6	95	280	80	2.5	95	180	81	1.6	95	100	84	0.93	95	90 (B5) 80 (B5)

Z 32 (AX-DX) Versione moltiplicatore / Multiplier version / Ausführung übersetzungsgetriebe																	22
ir	$n_1 = 1400 \text{ min}^{-1}$				$n_1 = 900 \text{ min}^{-1}$				$n_1 = 500 \text{ min}^{-1}$				IEC				
	n_2 min ⁻¹	T_{2M} Nm	P kW	RD %	n_2 min ⁻¹	T_{2M} Nm	P kW	RD %	n_2 min ⁻¹	T_{2M} Nm	P kW	RD %					
1.5	2100	81	18.8	95	1350	80	11.9	95	750	89	7.3	95	—				
2	2800	70	22	95	1800	71	14.1	95	1000	74	8.1	95					

Z 38 (A-AS-AD-AP-C-DR-B-BD-BS-AH-BH)																	37
ir	$n_1 = 2800 \text{ min}^{-1}$				$n_1 = 1400 \text{ min}^{-1}$				$n_1 = 900 \text{ min}^{-1}$				$n_1 = 500 \text{ min}^{-1}$				IEC
	n_2 min ⁻¹	T_{2M} Nm	P kW	RD %	n_2 min ⁻¹	T_{2M} Nm	P kW	RD %	n_2 min ⁻¹	T_{2M} Nm	P kW	RD %	n_2 min ⁻¹	T_{2M} Nm	P kW	RD %	
1	2800	371	115	95	1400	393	61	95	900	403	40	95	500	420	23	95	132 (B5) 112 (B5) 100 (B5) 90 (B5)
1.5	1867	356	73	95	933	374	39	95	600	382	25	95	333	397	14.6	95	
2	1400	255	39	95	700	268	21	95	450	476	13.7	95	250	483	7.8	95	
3	933	192	19.8	95	467	200	10.3	95	300	205	6.8	95	167	211	3.9	95	
4	700	209	16.1	95	350	217	8.4	95	225	221	5.5	95	125	226	3.1	95	
5	560	211	13.0	95	280	219	6.8	95	180	222	4.4	95	100	228	2.5	95	112/100 (B5) 90 (B5)

Z 38 (AX-DX) Versione moltiplicatore / Multiplier version / Ausführung übersetzungsgetriebe																	37
ir	$n_1 = 1400 \text{ min}^{-1}$				$n_1 = 900 \text{ min}^{-1}$				$n_1 = 500 \text{ min}^{-1}$				IEC				
	n_2 min ⁻¹	T_{2M} Nm	P kW	RD %	n_2 min ⁻¹	T_{2M} Nm	P kW	RD %	n_2 min ⁻¹	T_{2M} Nm	P kW	RD %					
1.5	2100	187	43	95	1350	191	28	95	750	198	16.4	95	—				
2	2800	134	41	95	1800	138	27	95	1000	142	15.6	95					

Z 42 (A-AS-AD-AP-C-DR-B-BD-BS-AH-BH)																	57
ir	$n_1 = 2800 \text{ min}^{-1}$				$n_1 = 1400 \text{ min}^{-1}$				$n_1 = 900 \text{ min}^{-1}$				$n_1 = 500 \text{ min}^{-1}$				IEC
	n_2 min ⁻¹	T_{2M} Nm	P kW	RD %	n_2 min ⁻¹	T_{2M} Nm	P kW	RD %	n_2 min ⁻¹	T_{2M} Nm	P kW	RD %	n_2 min ⁻¹	T_{2M} Nm	P kW	RD %	
1	2800	437	135	95	1400	461	71	95	900	474	47	95	500	494	27	95	160 (B5) 132 (B5) 112 (B5)
1.5	1867	339	70	95	933	421	43	95	600	434	29	95	333	447	16.4	95	
2	1400	299	46	95	700	316	24	95	450	324	16.1	95	250	334	9.2	95	
3	933	228	23	95	467	235	12.1	95	300	242	8.0	95	167	248	4.6	95	132/112 (B5)
4	700	234	18.1	95	350	243	9.4	95	225	248	6.2	95	125	254	3.5	95	
5	560	211	13.0	95	280	219	6.8	95	180	220	4.4	95	100	228	2.5	95	112 (B5)

Z 42 (AX-DX) Versione moltiplicatore / Multiplier version / Ausführung übersetzungsgetriebe																	57
ir	$n_1 = 1400 \text{ min}^{-1}$				$n_1 = 900 \text{ min}^{-1}$				$n_1 = 500 \text{ min}^{-1}$				IEC				
	n_2 min ⁻¹	T_{2M} Nm	P kW	RD %	n_2 min ⁻¹	T_{2M} Nm	P kW	RD %	n_2 min ⁻¹	T_{2M} Nm	P kW	RD %					
1.5	2100	211	49	95	1350	217	32	95	750	224	18.5	95	—				
2	2800	158	49	95	1800	162	32	95	1000	167	18.4	95					



1.7 Prestazioni rinvii angolari Z

1.7 Z gearboxes performances

1.7 Leistungen der Z-Getriebe

Z 55 (A-AS-AD-AP-C-DR-B-BD-BS-AH-BH)



87

ir	$n_1 = 2800 \text{ min}^{-1}$				$n_1 = 1400 \text{ min}^{-1}$				$n_1 = 900 \text{ min}^{-1}$				$n_1 = 500 \text{ min}^{-1}$				IEC
	n_2 min ⁻¹	T _{2M} Nm	P kW	RD %	n_2 min ⁻¹	T _{2M} Nm	P kW	RD %	n_2 min ⁻¹	T _{2M} Nm	P kW	RD %	n_2 min ⁻¹	T _{2M} Nm	P kW	RD %	
1	—	—	—	—	1400	992	153	95	900	1023	101	95	500	1053	58	95	160 (B5) 132 (B5) 112 (B5)
1.5	—	—	—	—	933	1057	109	95	600	1086	72	95	333	1123	41	95	
2	—	—	—	—	700	706	54	95	450	729	36	95	250	749	21	95	
3	—	—	—	—	467	481	25	95	300	497	16.4	95	167	508	9.3	95	132 (B5) 112 (B5)
4	—	—	—	—	350	621	24	95	225	636	15.8	95	125	651	9.0	95	
5	—	—	—	—	280	595	18.4	95	180	607	12.0	95	100	621	6.8	95	

Z 55 (AX-DX) Versione moltiplicatore / Multiplier version / Ausführung übersetzungsgetriebe



87

ir	$n_1 = 1400 \text{ min}^{-1}$				$n_1 = 900 \text{ min}^{-1}$				$n_1 = 500 \text{ min}^{-1}$				IEC
	n_2 min ⁻¹	T _{2M} Nm	P kW	RD %	n_2 min ⁻¹	T _{2M} Nm	P kW	RD %	n_2 min ⁻¹	T _{2M} Nm	P kW	RD %	
1.5	2100	529	122	95	1350	543	81	95	750	562	46	95	—
2	2800	353	109	95	1800	365	72	95	1000	375	41	95	

Z 75 (A-AS-AD-AP-C-DR-B-BD-BS-AH-BH)



255

ir	$n_1 = 2800 \text{ min}^{-1}$				$n_1 = 1400 \text{ min}^{-1}$				$n_1 = 900 \text{ min}^{-1}$				$n_1 = 500 \text{ min}^{-1}$				IEC
	n_2 min ⁻¹	T _{2M} Nm	P kW	RD %	n_2 min ⁻¹	T _{2M} Nm	P kW	RD %	n_2 min ⁻¹	T _{2M} Nm	P kW	RD %	n_2 min ⁻¹	T _{2M} Nm	P kW	RD %	
1	—	—	—	—	1400	2109	325	95	900	2202	218	95	500	2301	127	95	—
1.5	—	—	—	—	933	1754	180	95	600	1817	120	95	333	1888	69	95	
2	—	—	—	—	700	1723	133	95	450	1778	88	95	250	1841	51	95	
3	—	—	—	—	467	1772	91	95	300	1823	60	95	167	1881	35	95	
4	—	—	—	—	350	1466	57	95	225	1505	37	95	125	1547	21	95	
5	—	—	—	—	280	1278	39	95	180	1309	26	95	100	1342	14.8	95	

Z 75 (AX-DX) Versione moltiplicatore / Multiplier version / Ausführung übersetzungsgetriebe



255

ir	$n_1 = 1400 \text{ min}^{-1}$				$n_1 = 900 \text{ min}^{-1}$				$n_1 = 500 \text{ min}^{-1}$				IEC
	n_2 min ⁻¹	T _{2M} Nm	P kW	RD %	n_2 min ⁻¹	T _{2M} Nm	P kW	RD %	n_2 min ⁻¹	T _{2M} Nm	P kW	RD %	
1.5	2100	877	203	95	1350	909	135	95	750	944	78	95	—
2	2800	862	266	95	1800	889	176	95	1000	921	101	95	

I pesi riportati si riferiscono al modello base versione A, rapporto ir=1.

The following weights refer to basic model (A version), ratio ir=1.

Die folgenden Gewichte beziehen sich auf das Grundmodell (Version A), Untersetzung ir=1.

Nella tab. 4.6 sono riportate le dimensioni IEC e le possibili combinazioni albero/flangia rinvio angolare predisposto per accoppiamento motore.

In table 4.6 are listed the IEC dimensions as well as the possible shaft/flange combinations of the gearbox to be coupled with a motor.

In Tabelle 4.6 sind sowohl die IEC-Anschlußmaße als auch weitere mögliche Welle/Flansch-Kombinationen zur Motorbefestigung aufgeführt.

Tab. 4.6

Possibili accoppiamenti con motori IEC / Possible couplings with IEC motors / Mögliche Verbindungen mit IEC-Motoren						
	IEC	ir				
		1	1.5	2	3	4
Z 12	71	14/105 (B14)				
	63	11/140 (B5)				
Z 19	71	14/160 (B5)				
	63	11/140 (B5)				
Z 24	90	24/200 (B5)				
	80	19/200 (B5)				
	71	14/160 (B5)				
Z 32	100/112	28/250 (B5)				
	90	24/200 (B5)				
	80	19/200 (B5)				
Z 38	132	38/300 (B5)				
	100/112	28/250 (B5)				
	90	24/200 (B5)				
Z 42	160	42/350 (B5)				
	132	38/300 (B5)				
	100/112	28/250 (B5)				
Z 55	160	42/350 (B5)				
	132	38/300 (B5)				
	100/112	28/250 (B5)				

Legenda:

11/140 (B5)

11/140 : combinazioni albero/flangia standard (B5) : forma costruttiva motore IEC

Key:

11/140 (B5)

11/140 : standard shaft/flange combination (B5) : IEC motor constructive shape

Legende:

11/140 (B5)

11/140 : Standardkombinationen Welle/Flansch (B5) : Konstruktionsform IEC-Motor

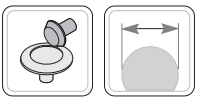

1.8 Dimensioni

1.8 Dimensions

1.8 Abmessungen

Z.A

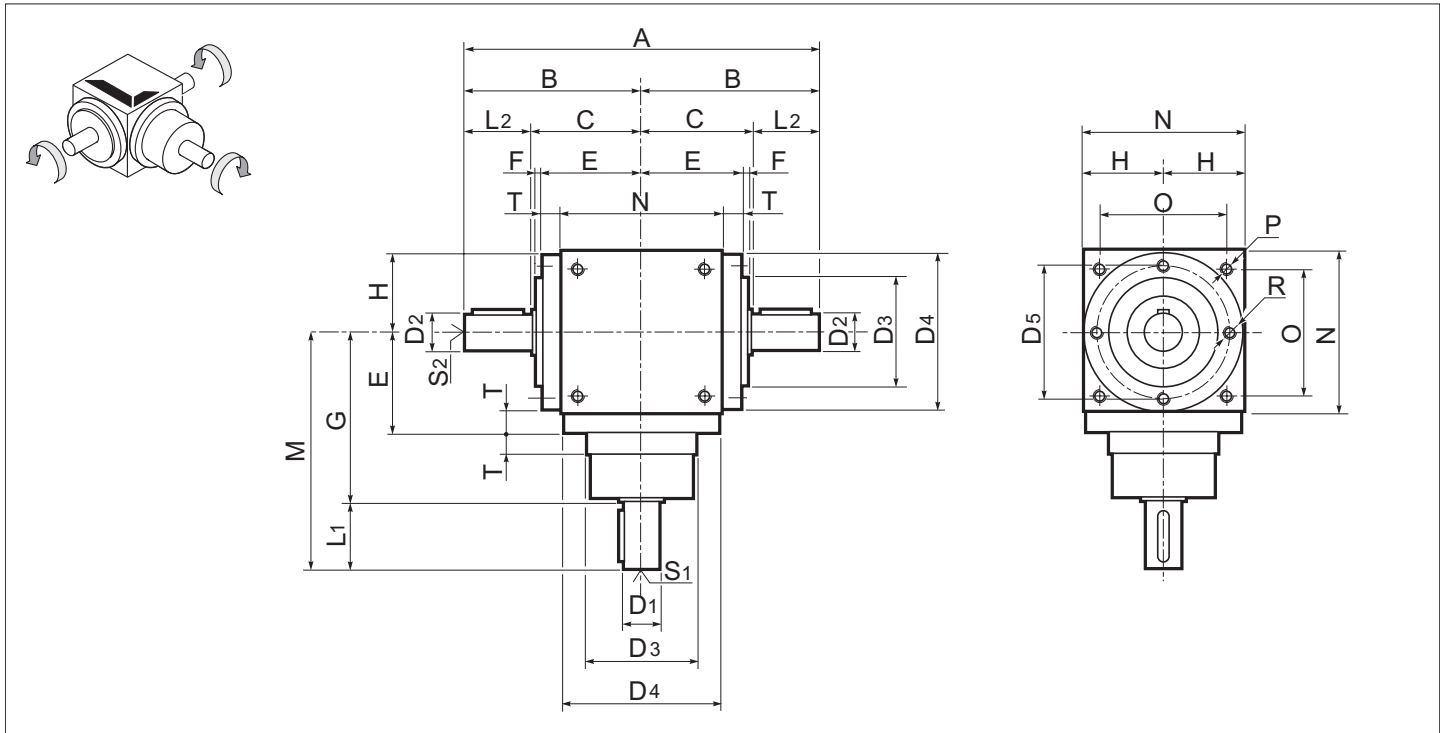

Z.MA

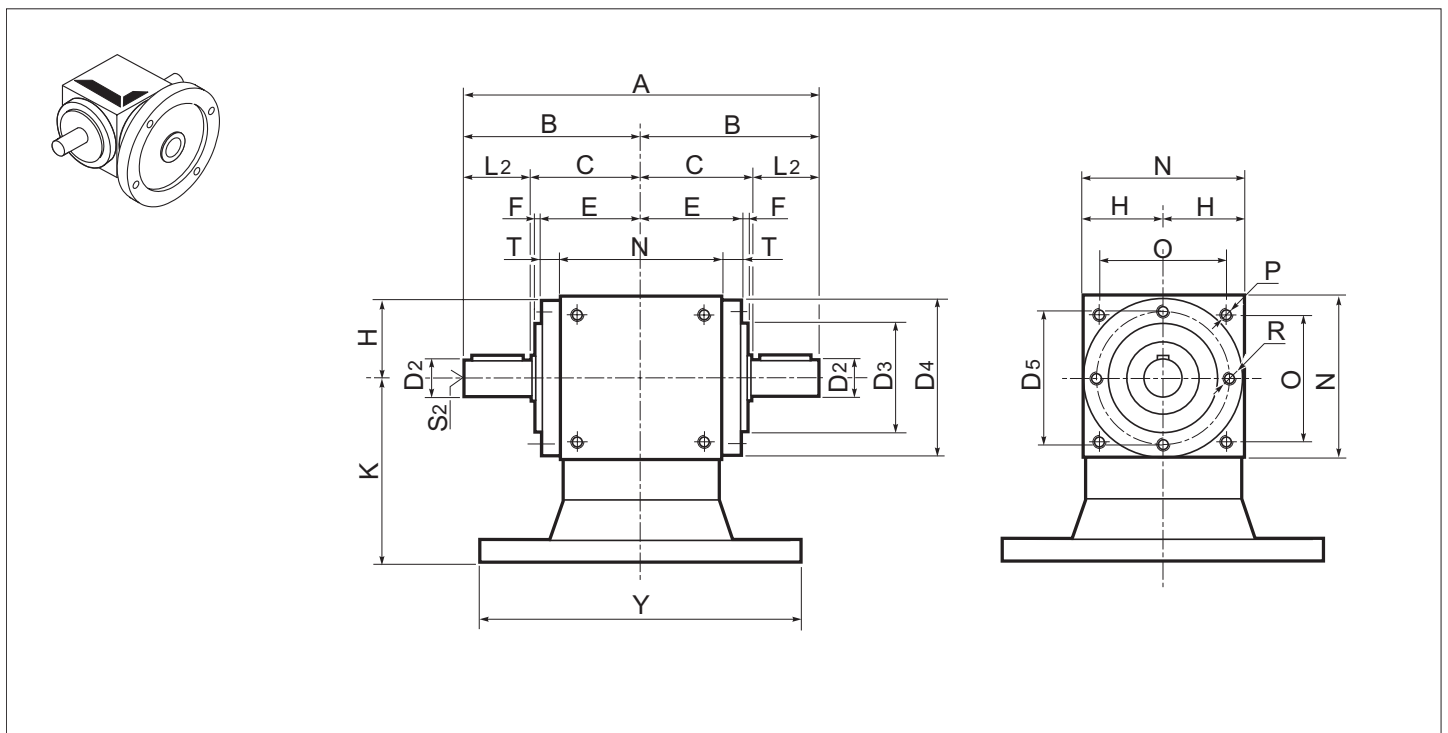



1.8 Dimensioni

1.8 Dimensions

1.8 Abmessungen

Z.A	C	D3 h8	D4	D5	E	F	G	H	N	O	P	R	T
12	46	44	-	54	42	2	74	32.5	65	45	M6	M6	-
19	65	60	86	72	59	4	100	45	90	70	M6	M6	14
24	80	70	105	88	73	5	115	55	110	88	M8	M8	18
32	95	95	135	115	88	5	145	70	140	110	M10	M10	18
38	110	120	165	145	103	5	170	85	170	136	M12	M12	18
42	125	135	190	165	118	5	195	100	200	155	M12	M12	18
55	150	170	230	205	143	5	245	120	240	190	M14	M14	23
75	225	-	300	-	195	-	350	165	330	248	M16	M16	30

Z.A	ir	A	B	M	Albero entrata / Input shaft / Antriebswelle			Albero uscita / Output shaft / Abtriebswelle		
					D1 j6	L1	S1	D2 j6	L2	S2
12	1-2-3	144	72	100	12	26	M4x8	12	26	M4x8
19	1-2-3	210	105	140	19	40	M6x12	19	40	M6x12
	4-5			130	14	30	M5x10			
24	1-2-3	260	130	165	24	50	M8x16	24	50	M8x16
	4-5			155	19	40	M6x12			
32	1-2-3	310	155	205	32	60	M10x20	32	60	M10x20
	4-5			195	24	50	M8x16			
38	1-2-3	360	180	240	38	70	M12x24	38	70	M12x24
	4-5			230	28	60	M10x20			
42	1-2-3	410	205	275	42	80	M12x24	42	80	M12x24
	4-5			255	32	60	M10x20			
55	1-2-3	520	260	355	55	110	M14x28	55	110	M14x28
	4-5			325	42	80	M12x24			
75	1-2-3	750	375	500	75	150	M16x32	75	150	M16x32
	4-5			460	55	110	M14x28			

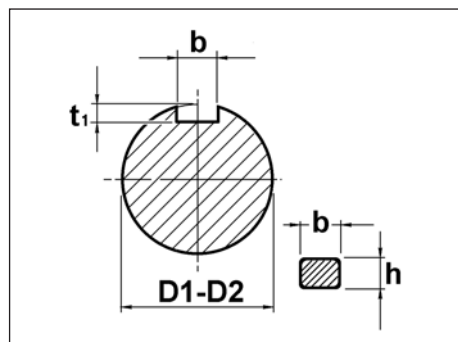

D1 - D2	b x h	t ₁
12	4 x 4	2.5
14	5 x 5	3.0
19	6 x 6	3.5
24	8 x 7	4.0
28	8 x 7	4.0
32	10 x 8	4.0
38	10 x 8	5.0
42	12 x 8	5.0
55	16 x 10	6.0
75	22 x 14	9.0

Z.MA	IEC	12		19		24		32		38		42		55	
		Y	K	Y	K	Y	K	Y	K	Y	K	Y	K	Y	K
	B5	105 (B14)	90	140	90	160	120	200	140	200	155	250	200	250	220
		140	90	160	90	200	120	250	140	250	155	300	200	300	220
										300	175	350	200	350	220

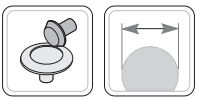

Z.AS - Z.AD

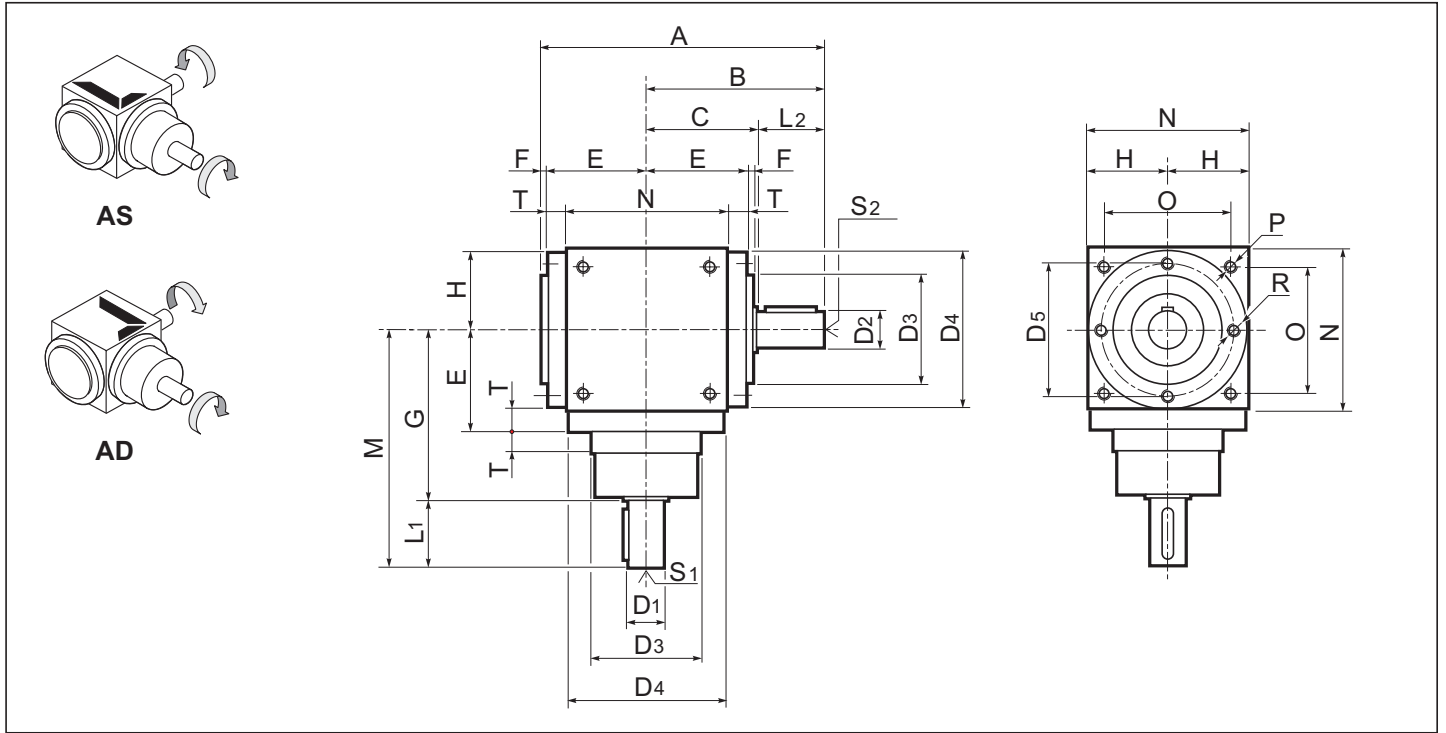

Z.MAS - Z.MAD

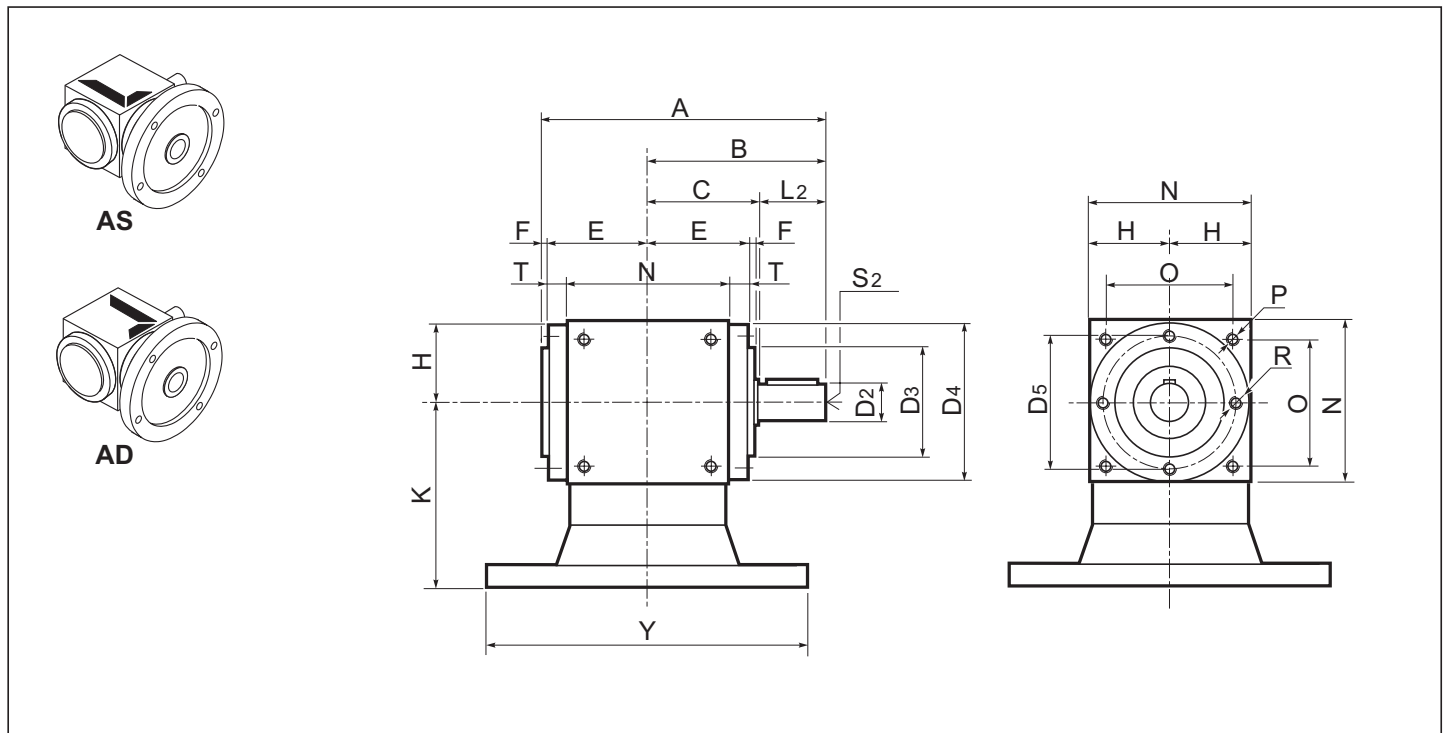

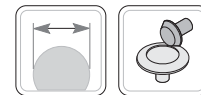

1.8 Dimensioni

1.8 Dimensions

1.8 Abmessungen

Z.AS Z.AD	C	D3 h8	D4	D5	E	F	G	H	N	O	P	R	T
12	46	44	-	54	42	2	74	32.5	65	45	M6	M6	-
19	65	60	86	72	59	4	100	45	90	70	M6	M6	14
24	80	70	105	88	73	5	115	55	110	88	M8	M8	18
32	95	95	135	115	88	5	145	70	140	110	M10	M10	18
38	110	120	165	145	103	5	170	85	170	136	M12	M12	18
42	125	135	190	165	118	5	195	100	200	155	M12	M12	18
55	150	170	230	205	143	5	245	120	240	190	M14	M14	23
75	225	-	300	-	195	-	350	165	330	248	M16	M16	30

Z.AS Z.AD	ir	A	B	M	Albero entrata / Input shaft / Antriebswelle			Albero uscita / Output shaft / Abtriebswelle		
					D1 j6	L1	S1	D2 j6	L2	S2
12	1-2-3	116	72	100	12	26	M4x8	12	26	M4x8
19	1-2-3	168	105	140	19	40	M6x12	19	40	M6x12
	4-5			130	14	30	M5x10			
24	1-2-3	208	130	165	24	50	M8x16	24	50	M8x16
	4-5			155	19	40	M6x12			
32	1-2-3	248	155	205	32	60	M10x20	32	60	M10x20
	4-5			195	24	50	M8x16			
38	1-2-3	288	180	240	38	70	M12x24	38	70	M12x24
	4-5			230	28	60	M10x20			
42	1-2-3	328	205	275	42	80	M12x24	42	80	M12x24
	4-5			255	32	60	M10x20			
55	1-2-3	408	260	355	55	110	M14x28	55	110	M14x28
	4-5			325	42	80	M12x24			
75	1-2-3	598	375	500	75	150	M16x32	75	150	M16x32
	4-5			460	55	110	M14x28			

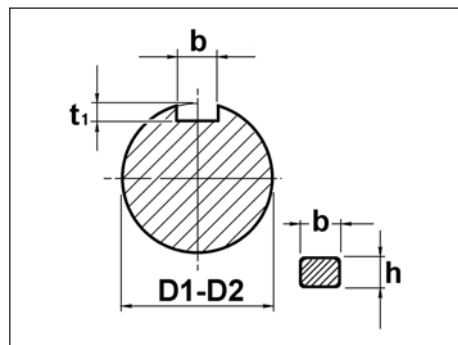

D1 - D2	b x h	t ₁
12	4 x 4	2.5
14	5 x 5	3.0
19	6 x 6	3.5
24	8 x 7	4.0
28	8 x 7	4.0
32	10 x 8	4.0
38	10 x 8	5.0
42	12 x 8	5.0
55	16 x 10	6.0
75	22 x 14	9.0

Z.MAS Z.MAD	IEC	12		19		24		32		38		42		55	
		Y	K	Y	K	Y	K	Y	K	Y	K	Y	K	Y	K
B5	105 (B14)	90	140	90	160	120	200	140	200	155	250	200	250	220	220
	140	90	160	90	200	120	250	140	250	155	300	200	300	220	220
									300	175	350	200	350	220	220

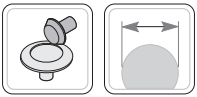

Z.AX

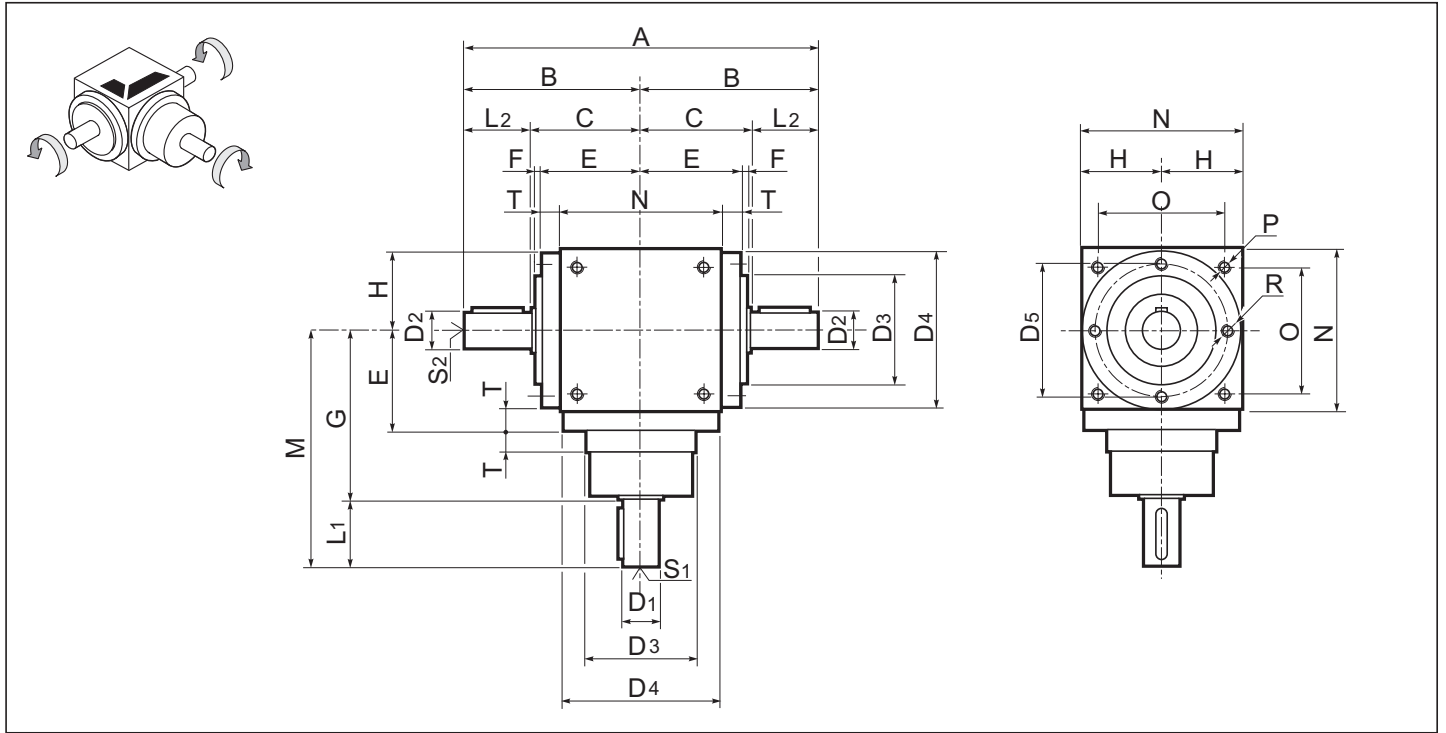



1.8 Dimensioni

1.8 Dimensions

1.8 Abmessungen

Z.AX	C	D3 h8	D4	D5	E	F	G	H	N	O	P	R	T
12	—	—	—	—	—	—	—	—	—	—	—	—	—
19	65	60	86	72	59	4	100	45	90	70	M6	M6	14
24	80	70	105	88	73	5	115	55	110	88	M8	M8	18
32	95	95	135	115	88	5	145	70	140	110	M10	M10	18
38	110	120	165	145	103	5	170	85	170	136	M12	M12	18
42	125	135	190	165	118	5	195	100	200	155	M12	M12	18
55	150	170	230	205	143	5	245	120	240	190	M14	M14	23
75	225	—	300	—	195	—	350	165	330	248	M16	M16	30

Z.AX	ir	A	B	M	Albero entrata / Input shaft / Antriebswelle			Albero uscita / Output shaft / Abtriebswelle		
					D1 j6	L1	S1	D2 j6	L2	S2
12	—	—	—	—	—	—	—	—	—	—
19	1.5	190	95	140	19	40	M6x12	14	30	M5x10
	2									
24	1.5	240	120	165	24	50	M8x16	19	40	M6x12
	2									
32	1.5	290	145	205	32	60	M10x20	24	50	M8x16
	2							19		
38	1.5	340	170	240	38	70	M12x24	28	60	M10x20
	2									
42	1.5	390	195	275	42	80	M12x24	38	70	M10x20
	2		370					185	32	
55	1.5	460	230	355	55	110	M14x28	42	80	M12x24
	2		440					220	38	70
75	1.5	670	335	500	75	150	M16x32	55	110	M14x28
	2									

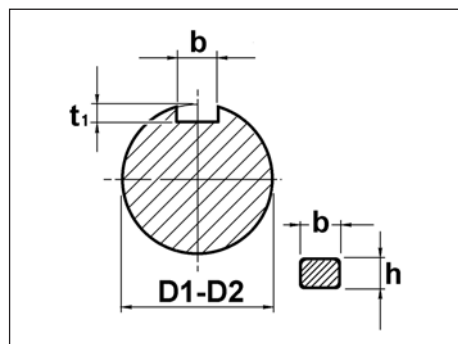

D1 - D2	b x h	t ₁	
12	4 x 4	2.5	
14	5 x 5	3.0	+0.1 0
19	6 x 6	3.5	
24	8 x 7	4.0	
28	8 x 7	4.0	
32	10 x 8	4.0	
38	10 x 8	5.0	+0.2 0
42	12 x 8	5.0	
55	16 x 10	6.0	
75	22 x 14	9.0	



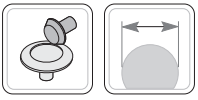

Z.AP

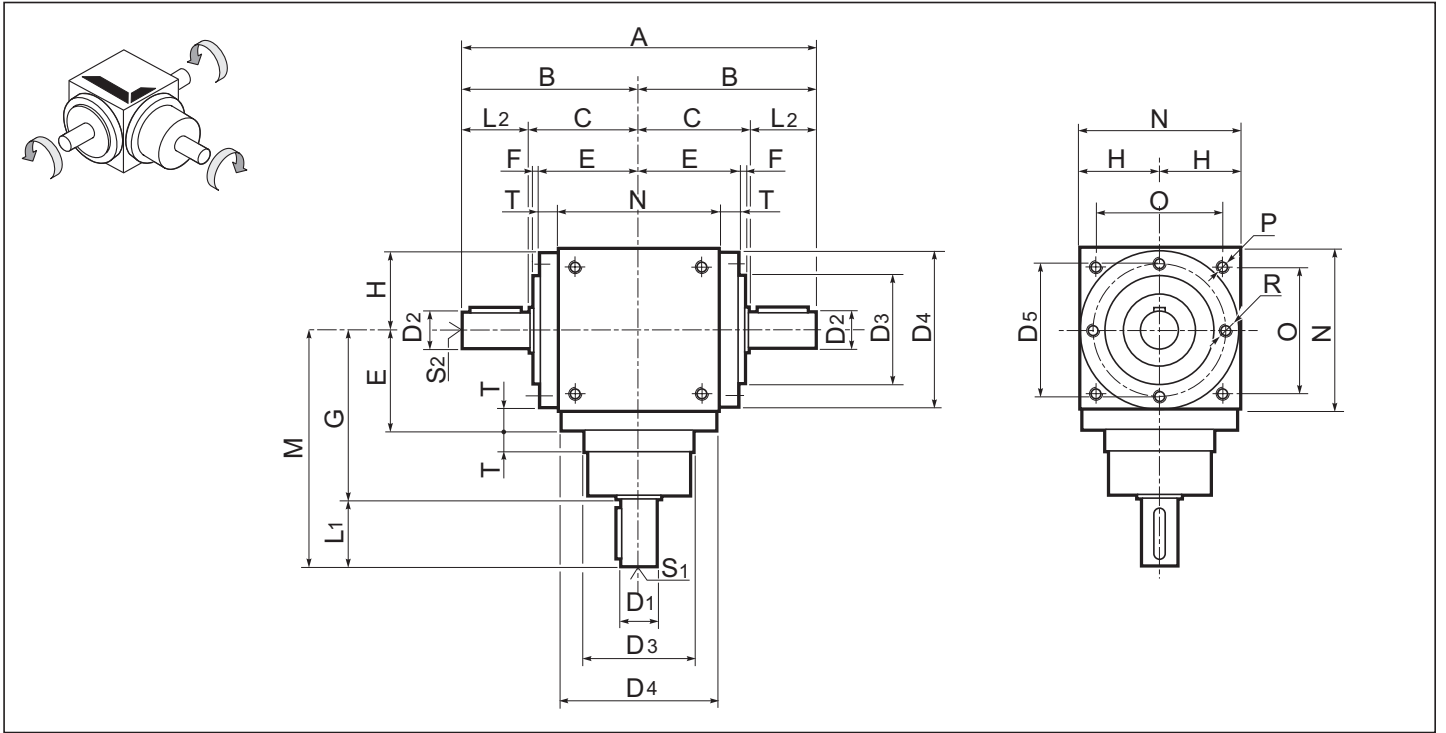



1.8 Dimensioni

1.8 Dimensions

1.8 Abmessungen

Z.AP	C	D3 h8	D4	D5	E	F	G	H	N	O	P	R	T
12	—	—	—	—	—	—	—	—	—	—	—	—	—
19	65	60	86	72	59	4	100	45	90	70	M6	M6	14
24	80	70	105	88	73	5	115	55	110	88	M8	M8	18
32	95	95	135	115	88	5	145	70	140	110	M10	M10	18
38	110	120	165	145	103	5	170	85	170	136	M12	M12	18
42	125	135	190	165	118	5	195	100	200	155	M12	M12	18
55	150	170	230	205	143	5	245	120	240	190	M14	M14	23
75	225	—	300	—	195	—	350	165	330	248	M16	M16	30

Z.AP	ir	A	B	M	Albero entrata / Input shaft / Antriebswelle			Albero uscita / Output shaft / Abtriebswelle				
					D1 j6	L1	S1	D2 j6	L2	S2		
12	1-2-3	—	—	—	—	—	—	—	—	—	—	—
19	1-2-3	230	115	140	19	40	M6x12	24	50	M8x16		
	4-5				130	30	M5x10					
24	1-2-3	280	140	165	24	50	M8x16	32	60	M10x20		
	4-5				155	40	M6x12					
32	1-2-3	330	165	205	32	60	M10x20	38	70	M12x24		
	4-5				195	24	M8x16					
38	1-2-3	380	190	240	38	70	M12x24	42	80	M12x24		
	4-5				230	28	M10x20					
42	1-2-3	430	215	275	42	80	M12x24	48	90	M14x28		
	4-5				255	32	M10x20					
55	1-2-3	520	260	355	55	110	M14x28	70	110	M14x28		
	4-5				325	42	M12x24					
75	1-2-3	750	375	500	75	150	M16x32	90	150	M16x32		
	4-5				460	55	M14x28					

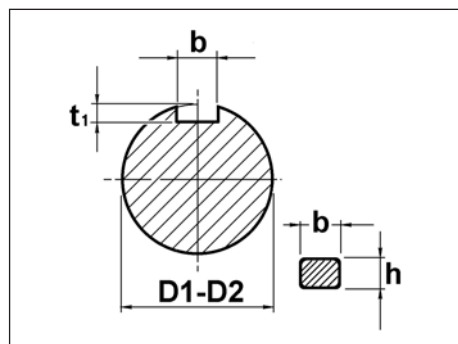

D1 - D2	b x h	t ₁
12	4 x 4	2.5
14	5 x 5	3.0
19	6 x 6	3.5
24	8 x 7	4.0
28	8 x 7	4.0
32	10 x 8	4.0
38	10 x 8	5.0
42	12 x 8	5.0
48	14 x 9	5.5
55	16 x 10	6.0
70	20 x 12	7.5
75	22 x 14	9.0
90	25 x 14	9.0



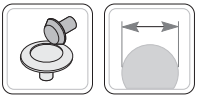

Z.C

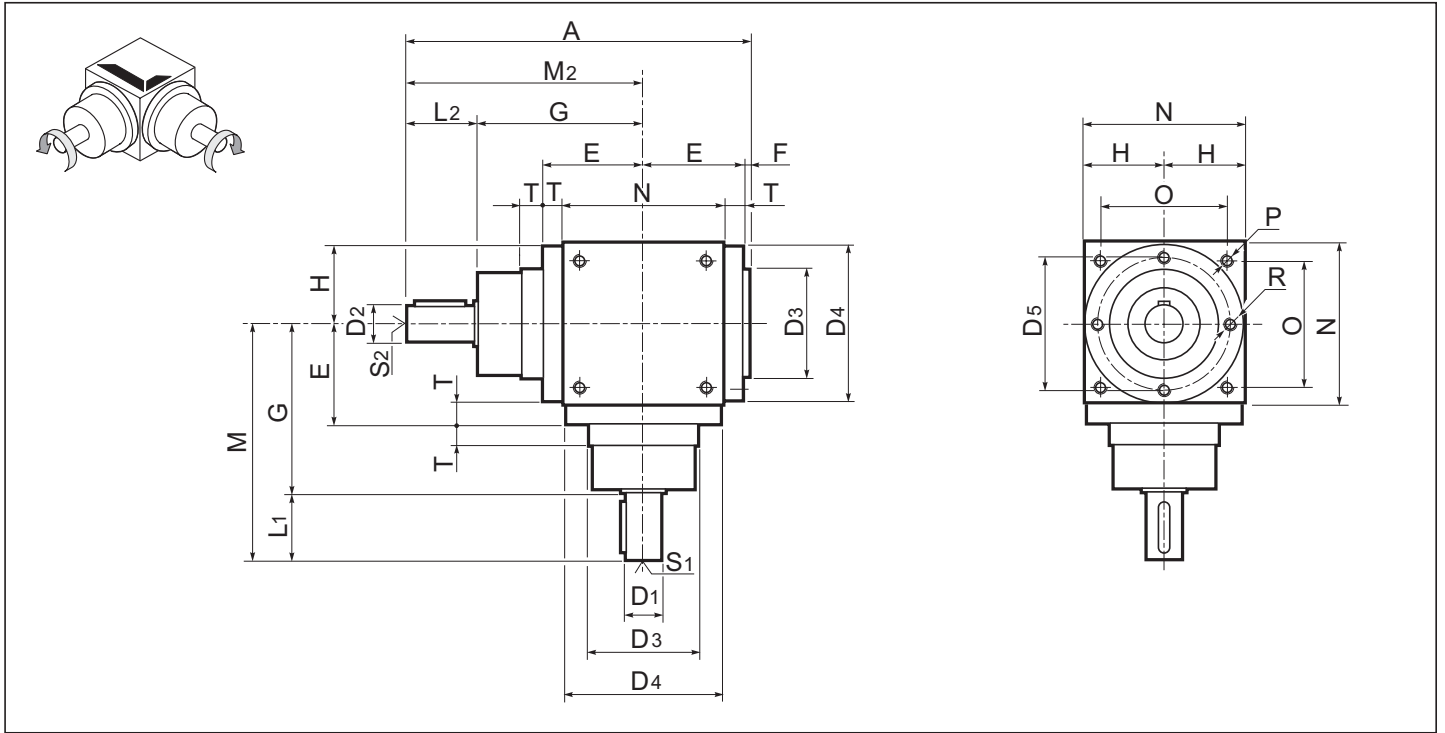

Z.MC

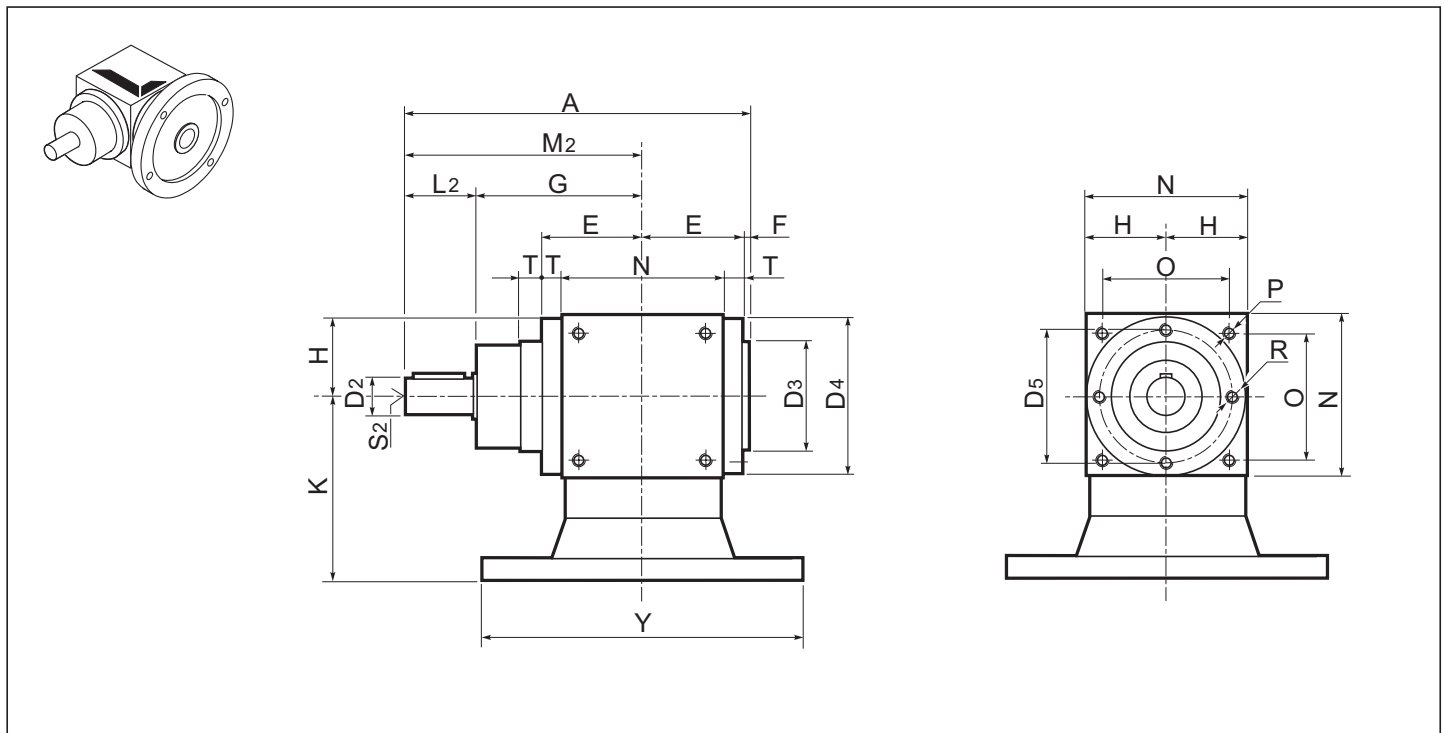



1.8 Dimensioni

1.8 Dimensions

1.8 Abmessungen

Z.C	D3 h8	D4	D5	E	F	G	H	N	O	P	R	T
12	44	-	54	42	2	74	32.5	65	45	M6	M6	-
19	60	86	72	59	4	100	45	90	70	M6	M6	14
24	70	105	88	73	5	115	55	110	88	M8	M8	18
32	95	135	115	88	5	145	70	140	110	M10	M10	18
38	120	165	145	103	5	170	85	170	136	M12	M12	18
42	135	190	165	118	5	195	100	200	155	M12	M12	18
55	170	230	205	143	5	245	120	240	190	M14	M14	23
75	-	300	-	195	-	350	165	330	248	M16	M16	30

Z.C	ir	A	M	M2	Albero entrata / Input shaft / Antriebswelle			Albero uscita / Output shaft / Abtriebswelle		
					D1 j6	L1	S1	D2 j6	L2	S2
12	1-2-3	144	100	100	12	26	M4x8	12	26	M4x8
19	1-2-3	203	140	140	19	40	M6x12	19	40	M6x12
	4-5		130		14	30	M5x10			
24	1-2-3	243	165	165	24	50	M8x16	24	50	M8x16
	4-5		155		19	40	M6x12			
32	1-2-3	298	205	205	32	60	M10x20	32	60	M10x20
	4-5		195		24	50	M8x16			
38	1-2-3	348	240	240	38	70	M12x24	38	70	M12x24
	4-5		230		28	60	M10x20			
42	1-2-3	398	275	275	42	80	M12x24	42	80	M12x24
	4-5		255		32	60	M10x20			
55	1-2-3	503	355	355	55	110	M14x28	55	110	M14x28
	4-5		325		42	80	M12x24			
75	1-2-3	723	500	500	75	150	M16x32	75	150	M16x32
	4-5		460		55	110	M14x28			

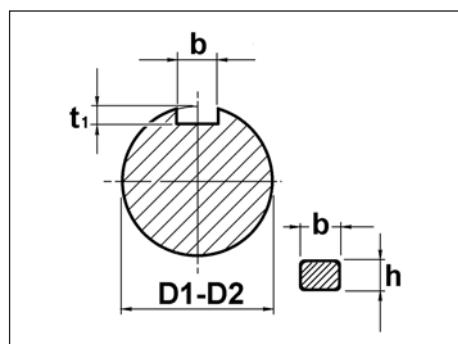

D1 - D2	b x h	t ₁	
12	4 x 4	2.5	
14	5 x 5	3.0	+0.1 0
19	6 x 6	3.5	
24	8 x 7	4.0	
28	8 x 7	4.0	
32	10 x 8	4.0	
38	10 x 8	5.0	+0.2 0
42	12 x 8	5.0	
55	16 x 10	6.0	
75	22 x 14	9.0	

Z.MC	IEC	12		19		24		32		38		42		55	
		Y	K	Y	K	Y	K	Y	K	Y	K	Y	K	Y	K
	B5	105 (B14)	90	140	90	160	120	200	140	200	155	250	200	250	220
	140	90	160	90	200	120	250	140	250	155	300	200	300	220	220
									300	175	350	200	350	220	220

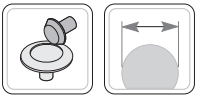

Z.DR

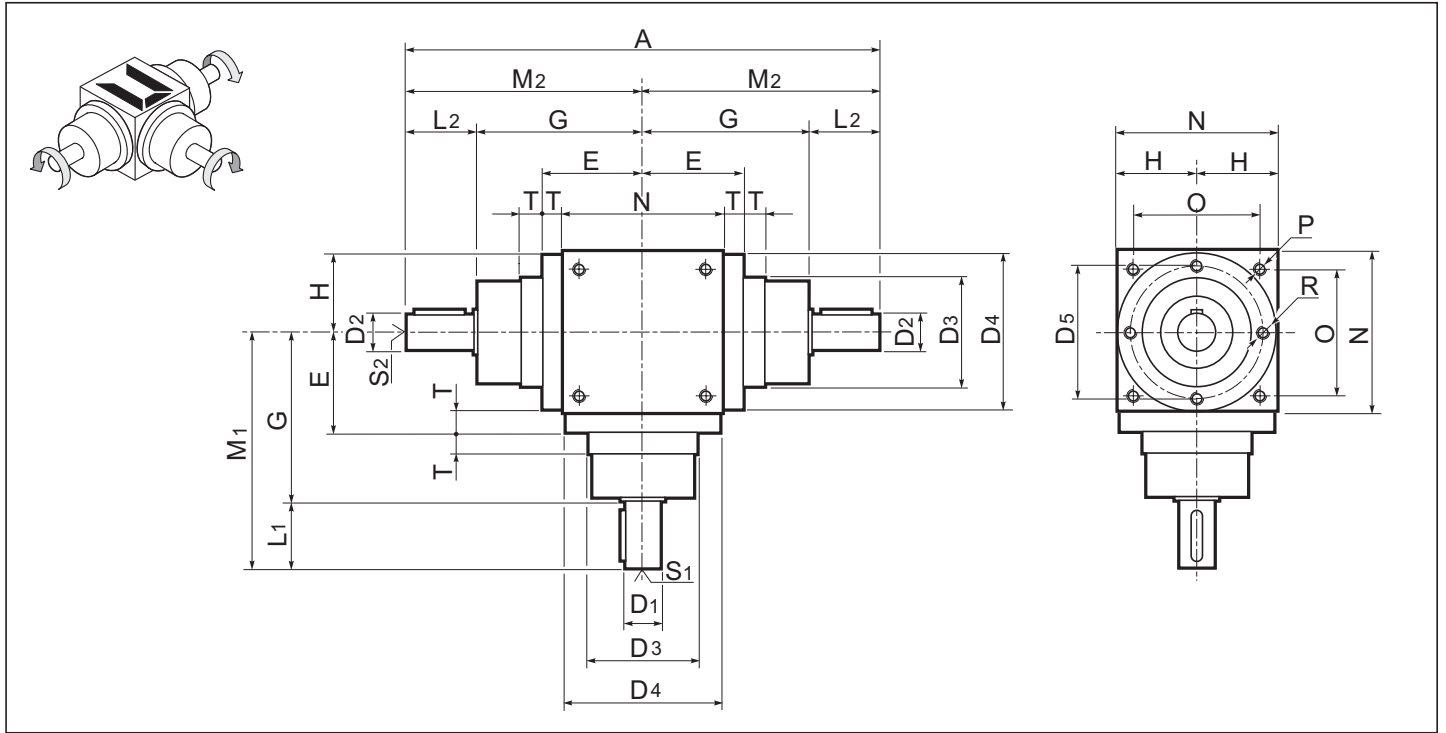

Z.MDR

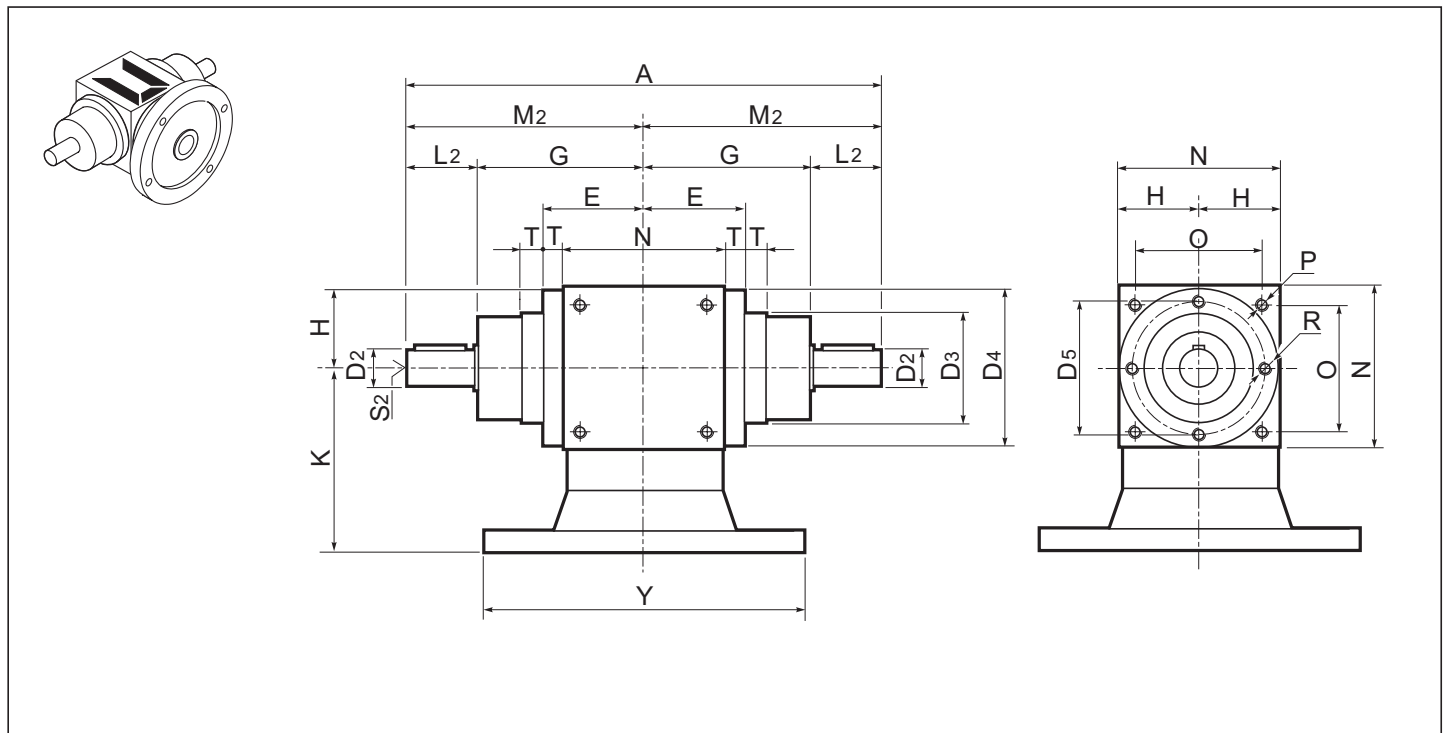

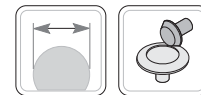

1.8 Dimensioni

1.8 Dimensions

1.8 Abmessungen

Z.DR	D3 h8	D4	D5	E	F	G	H	N	O	P	R	T
12	44	—	54	42	2	74	32.5	65	45	M6	M6	—
19	60	86	72	59	4	100	45	90	70	M6	M6	14
24	70	105	88	73	5	115	55	110	88	M8	M8	18
32	95	135	115	88	5	145	70	140	110	M10	M10	18
38	120	165	145	103	5	170	85	170	136	M12	M12	18
42	135	190	165	118	5	195	100	200	155	M12	M12	18
55	170	230	205	143	5	245	120	240	190	M14	M14	23
75	—	300	—	195	—	350	165	330	248	M16	M16	30

Z.DR	ir	A	M1	M2	Albero entrata / Input shaft / Antriebswelle			Albero uscita / Output shaft / Abtriebswelle		
					D1 j6	L1	S1	D2 j6	L2	S2
12	1-2-3	200	100	100	12	26	M4x8	12	26	M4x8
19	1-2-3	280	140	140	19	40	M6x12	19	40	M6x12
	4-5		130		14	30	M5x10			
24	1-2-3	330	165	165	24	50	M8x16	24	50	M8x16
	4-5		155		19	40	M6x12			
32	1-2-3	410	205	205	32	60	M10x20	32	60	M10x20
	4-5		195		24	50	M8x16			
38	1-2-3	480	240	240	38	70	M12x24	38	70	M12x24
	4-5		230		28	60	M10x20			
42	1-2-3	550	275	275	42	80	M12x24	42	80	M12x24
	4-5		255		32	60	M10x20			
55	1-2-3	710	355	355	55	110	M14x28	55	110	M14x28
	4-5		325		42	80	M12x24			
75	1-2-3	1000	500	500	75	150	M16x32	75	150	M16x32
	4-5		460		55	110	M14x28			

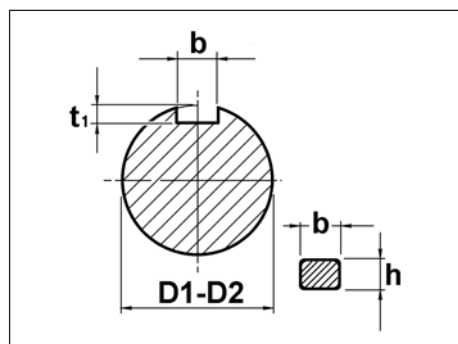

D1 - D2	b x h	t ₁
12	4 x 4	2.5
14	5 x 5	3.0
19	6 x 6	3.5
24	8 x 7	4.0
28	8 x 7	4.0
32	10 x 8	4.0
38	10 x 8	5.0
42	12 x 8	5.0
55	16 x 10	6.0
75	22 x 14	9.0

Z.MDR	IEC	12		19		24		32		38		42		55	
		Y	K	Y	K	Y	K	Y	K	Y	K	Y	K	Y	K
	B5	105 (B14)	90	140	90	160	120	200	140	200	155	250	200	250	220
		140	90	160	90	200	120	250	140	250	155	300	200	300	220
										300	175	350	200	350	220

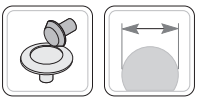

Z.DX

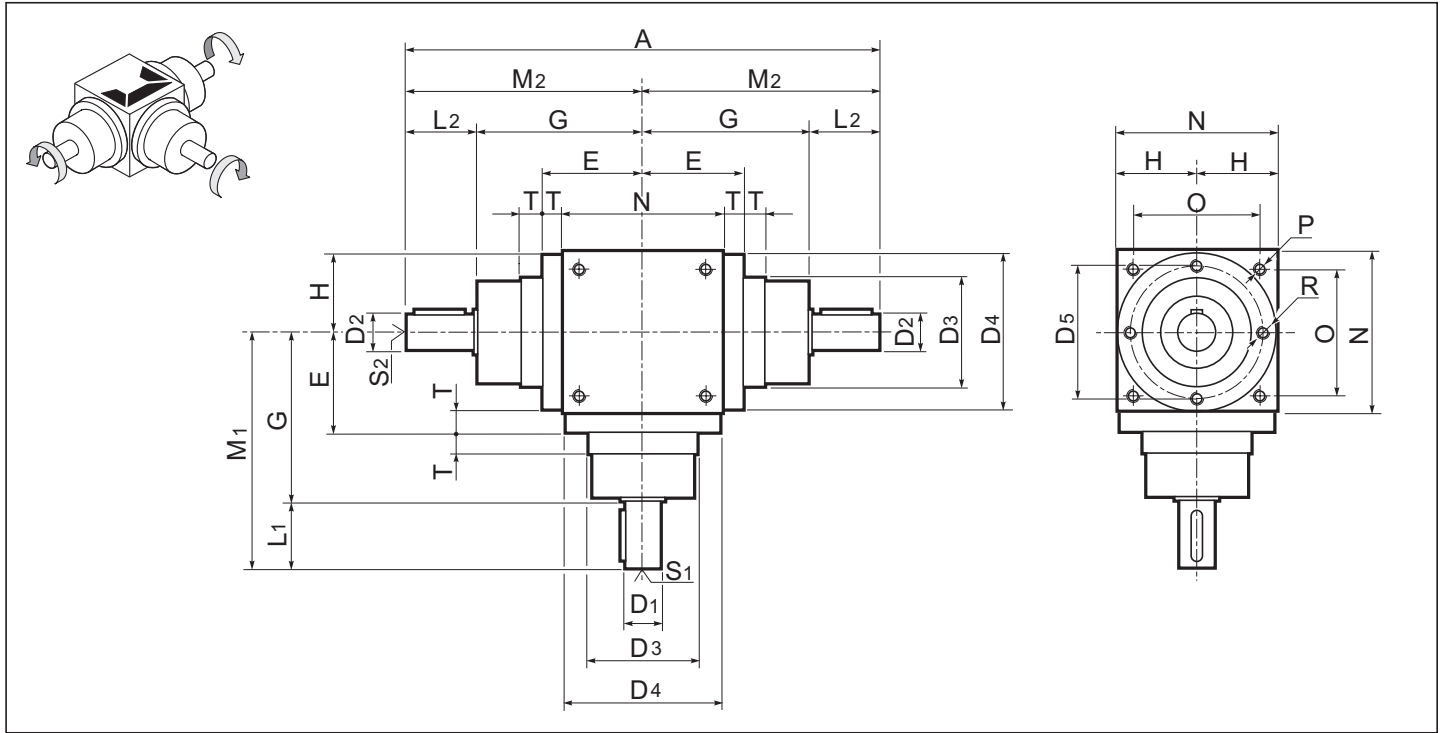

Z.MDX

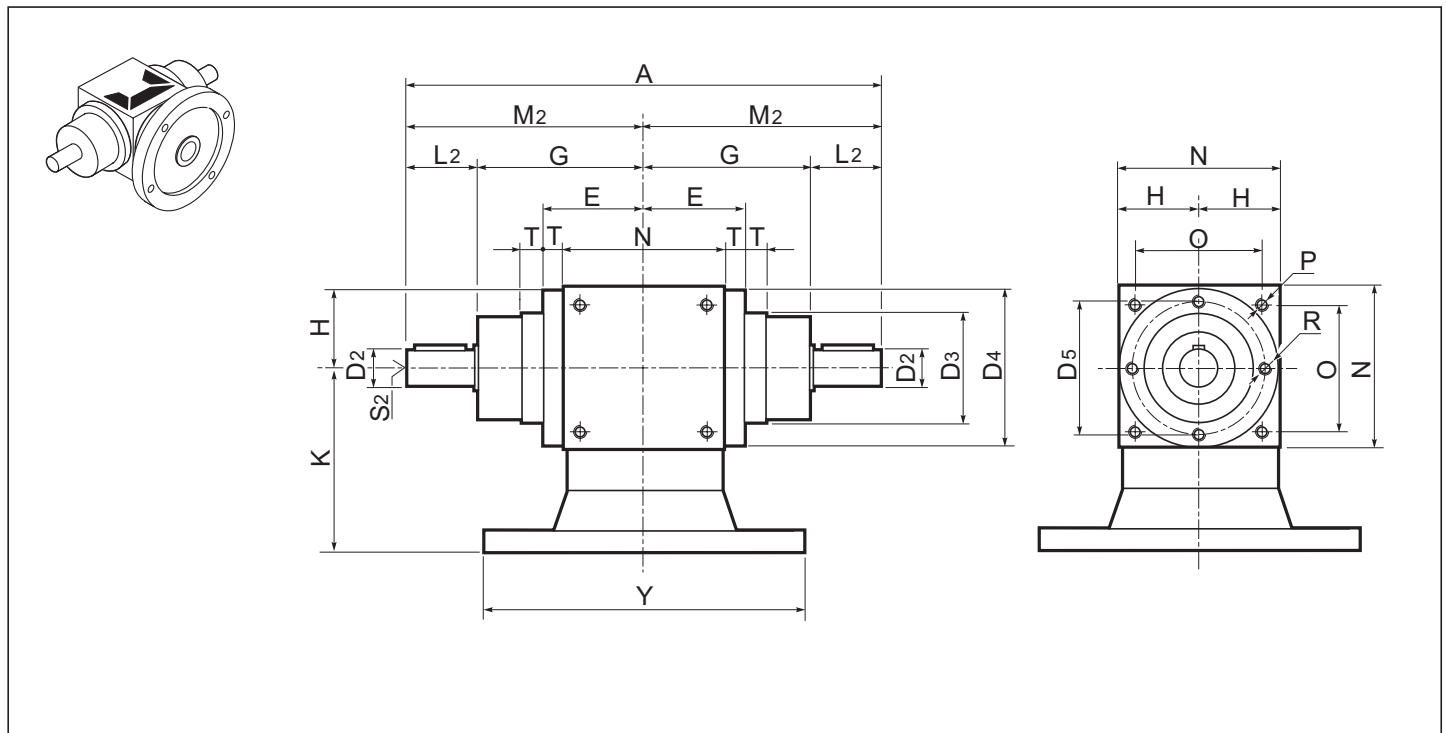



1.8 Dimensioni

1.8 Dimensions

1.8 Abmessungen

Z.DX	D3 h8	D4	D5	E	G	H	N	O	P	R	T
12	44	-	54	42	74	32.5	65	45	M6	M6	-
19	60	86	72	59	100	45	90	70	M6	M6	14
24	70	105	88	73	115	55	110	88	M8	M8	18
32	95	135	115	88	145	70	140	110	M10	M10	18
38	120	165	145	103	170	85	170	136	M12	M12	18
42	135	190	165	118	195	100	200	155	M12	M12	18
55	170	230	205	143	245	120	240	190	M14	M14	23
75	-	300	-	195	350	165	330	248	M16	M16	30

Z.DX	ir	A	M1	M2	Albero entrata / Input shaft / Antriebswelle			Albero uscita / Output shaft / Abtriebswelle		
					D1 j6	L1	S1	D2 j6	L2	S2
12	1-2-3	200	100	100	12	26	M4x8	12	26	M4x8
19	1-2-3	280	140	140	19	40	M6x12	19	40	M6x12
	4-5	260	130		14	30	M5x10			
24	1-2-3	330	165	165	24	50	M8x16	24	50	M8x16
	4-5	310	155		19	40	M6x12			
32	1-2-3	410	205	205	32	60	M10x20	32	60	M10x20
	4-5	390	195		24	50	M8x16			
38	1-2-3	480	240	240	38	70	M12x24	38	70	M12x24
	4-5	460	230		28	60	M10x20			
42	1-2-3	550	275	275	42	80	M12x24	42	80	M12x24
	4-5	510	255		32	60	M10x20			
55	1-2-3	710	355	355	55	110	M14x28	55	110	M14x28
	4-5	650	325		42	80	M12x24			
75	1-2-3	1000	500	500	75	150	M16x32	75	150	M16x32
	4-5	920	460		55	110	M14x28			

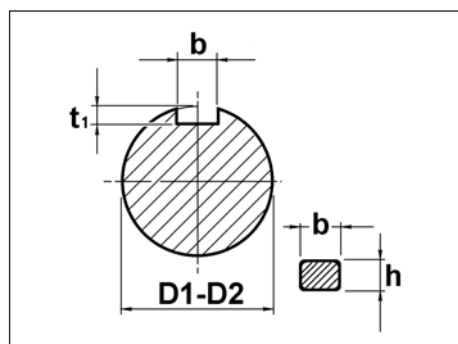

D1 - D2	b x h	t ₁	
12	4 x 4	2.5	
14	5 x 5	3.0	+0.1 0
19	6 x 6	3.5	
24	8 x 7	4.0	
28	8 x 7	4.0	
32	10 x 8	4.0	
38	10 x 8	5.0	+0.2 0
42	12 x 8	5.0	
55	16 x 10	6.0	
75	22 x 14	9.0	

Z.MDX	IEC	12		19		24		32		38		42		55	
		Y	K	Y	K	Y	K	Y	K	Y	K	Y	K	Y	K
	B5	105 (B14)	90	140	90	160	120	200	140	200	155	250	200	250	220
	140	90	160	90	200	120	250	140	250	155	300	200	300	220	220
									300	175	350	200	350	220	220

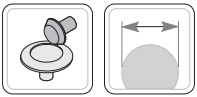

Z.B

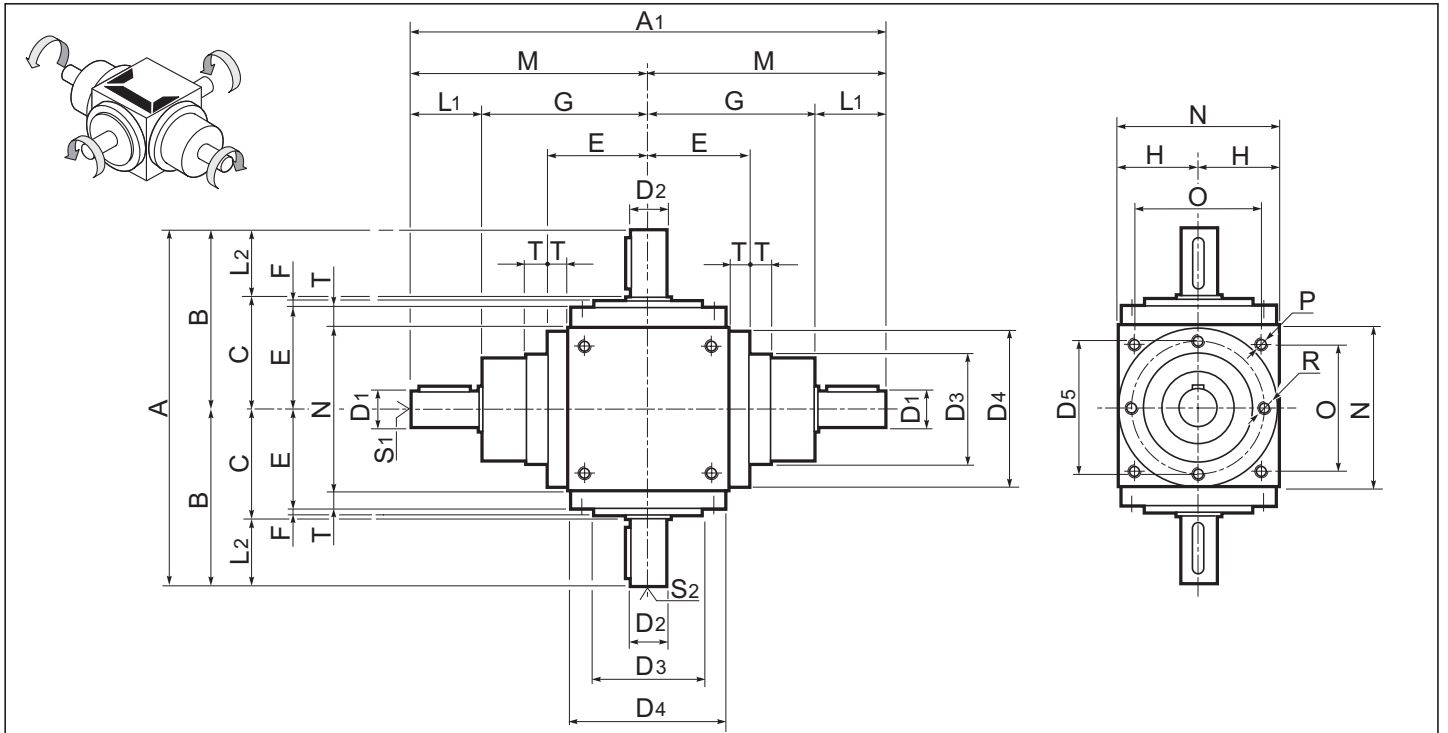

Z.MB

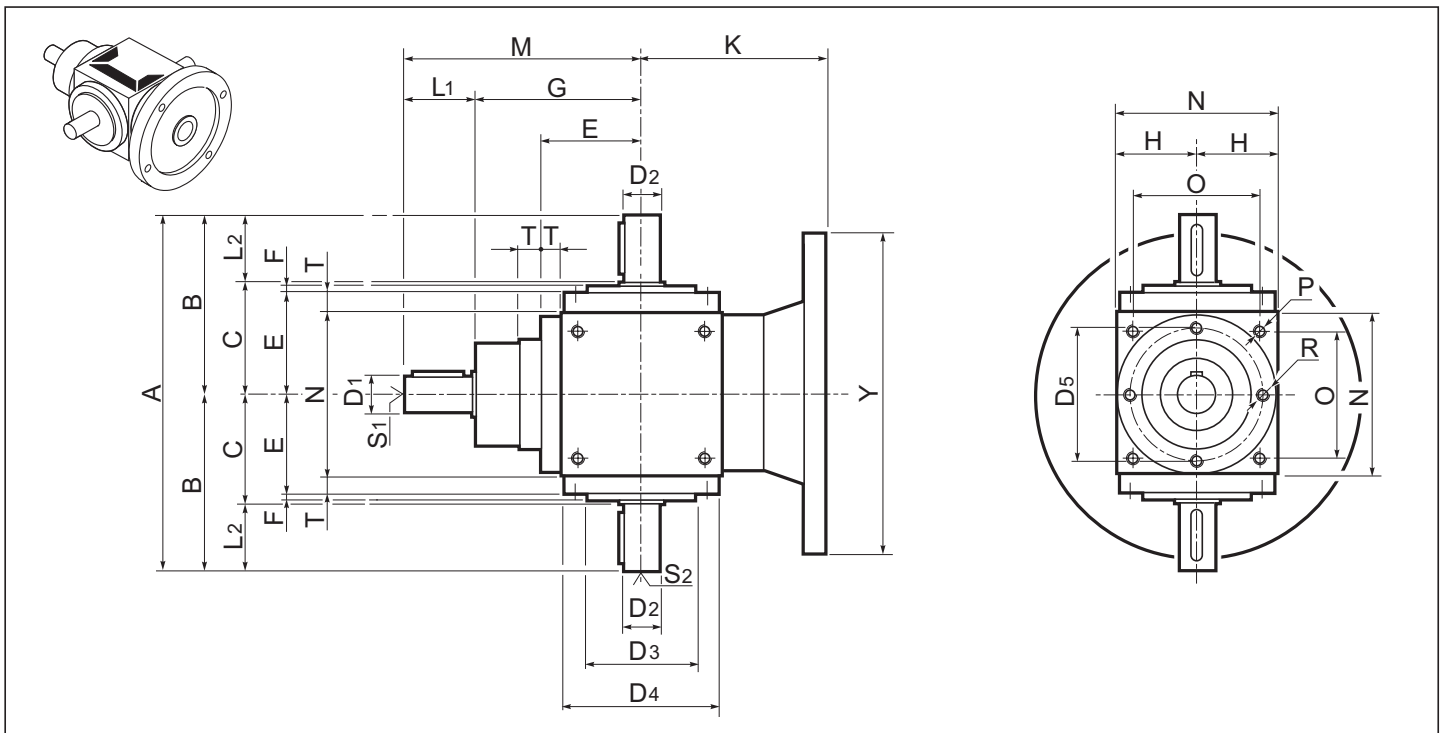



1.8 Dimensioni

1.8 Dimensions

1.8 Abmessungen

Z.B	C	D3 h8	D4	D5	E	F	G	H	N	O	P	R	T
12	46	44	—	54	42	2	74	32.5	65	45	M6	M6	—
19	65	60	86	72	59	4	100	45	90	70	M6	M6	14
24	80	70	105	88	73	5	115	55	110	88	M8	M8	18
32	95	95	135	115	88	5	145	70	140	110	M10	M10	18
38	110	120	165	145	103	5	170	85	170	136	M12	M12	18
42	125	135	190	165	118	5	195	100	200	155	M12	M12	18
55	150	170	230	205	143	5	245	120	240	190	M14	M14	23
75	225	—	300	—	195	—	350	165	330	248	M16	M16	30

Z.B	ir	A1	A2	B	M	Albero entrata / Input shaft / Antriebswelle			Albero uscita / Output shaft / Abtriebswelle		
						D1 j6	L1	S1	D2 j6	L2	S2
12	1-2-3	200	144	72	100	12	26	M4x8	12	26	M4x8
19	1-2-3	280	210	105	140	19	40	M6x12	19	40	M6x12
	4-5	260			130	14	30	M5x10			
24	1-2-3	330	260	130	165	24	50	M8x16	24	50	M8x16
	4-5	310			155	19	40	M6x12			
32	1-2-3	410	310	155	205	32	60	M10x20	32	60	M10x20
	4-5	390			195	24	50	M8x16			
38	1-2-3	480	360	180	240	38	70	M12x24	38	70	M12x24
	4-5	460			230	28	60	M10x20			
42	1-2-3	550	410	205	275	42	80	M12x24	42	80	M12x24
	4-5	510			255	32	60	M10x20			
55	1-2-3	710	520	260	355	55	110	M14x28	55	110	M14x28
	4-5	650			325	42	80	M12x24			
75	1-2-3	1000	750	375	500	75	150	M16x32	75	150	M16x32
	4-5	920			460	55	110	M14x28			

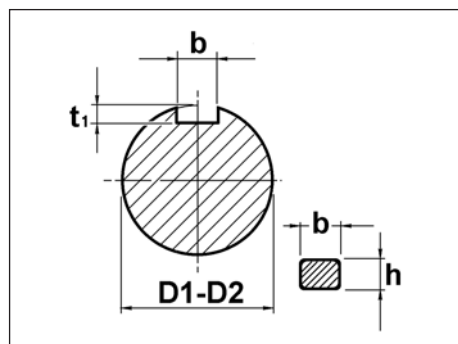

D1 - D2	b x h	t ₁
12	4 x 4	2.5
14	5 x 5	3.0
19	6 x 6	3.5
24	8 x 7	4.0
28	8 x 7	4.0
32	10 x 8	4.0
38	10 x 8	5.0
42	12 x 8	5.0
55	16 x 10	6.0
75	22 x 14	9.0

Z.MB	IEC	12		19		24		32		38		42		55	
		Y	K	Y	K	Y	K	Y	K	Y	K	Y	K		
	B5	105 (B14)	90	140	90	160	120	200	140	200	155	250	200	250	220
		140	90	160	90	200	120	250	140	250	155	300	200	300	220
										300	175	350	200	350	220

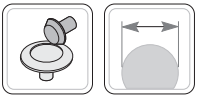

Z.BS - Z.BD

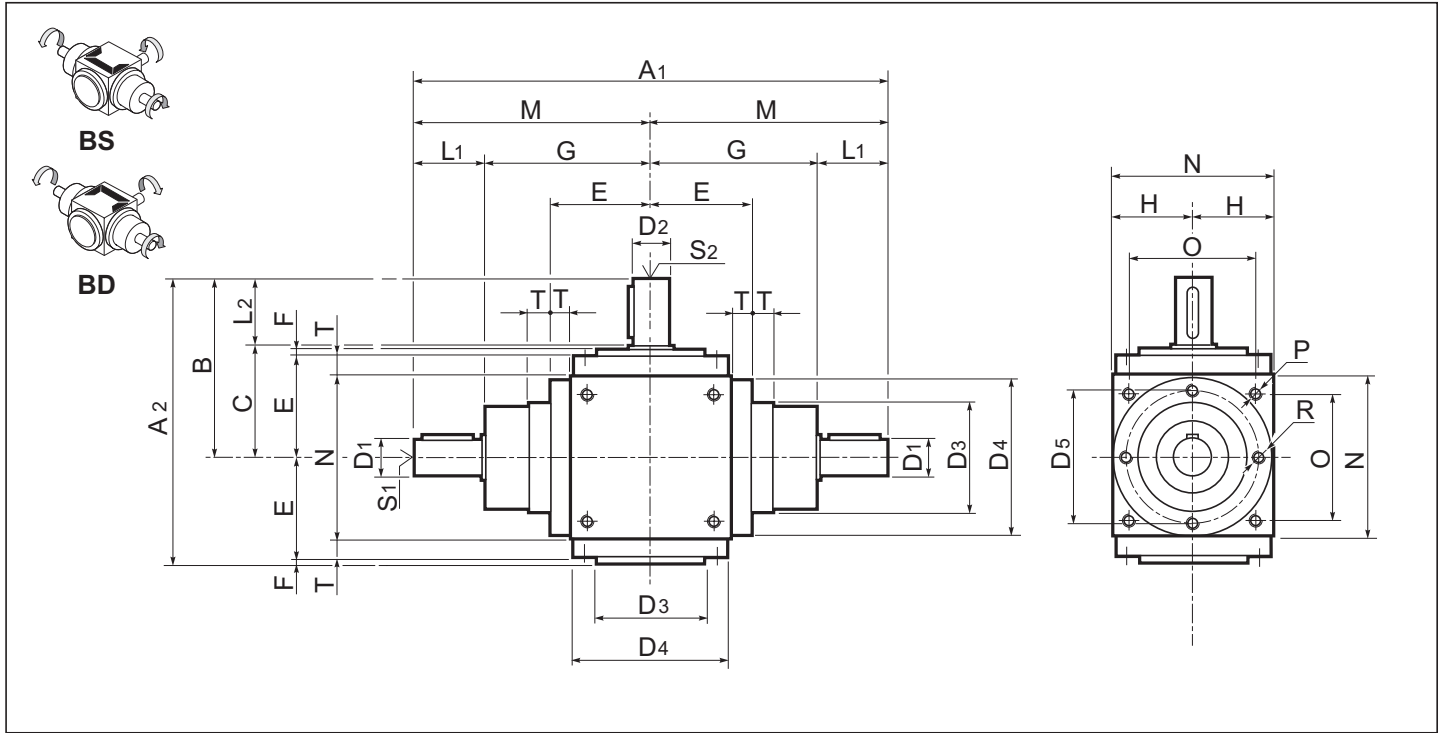

Z.MBS - Z.MBD

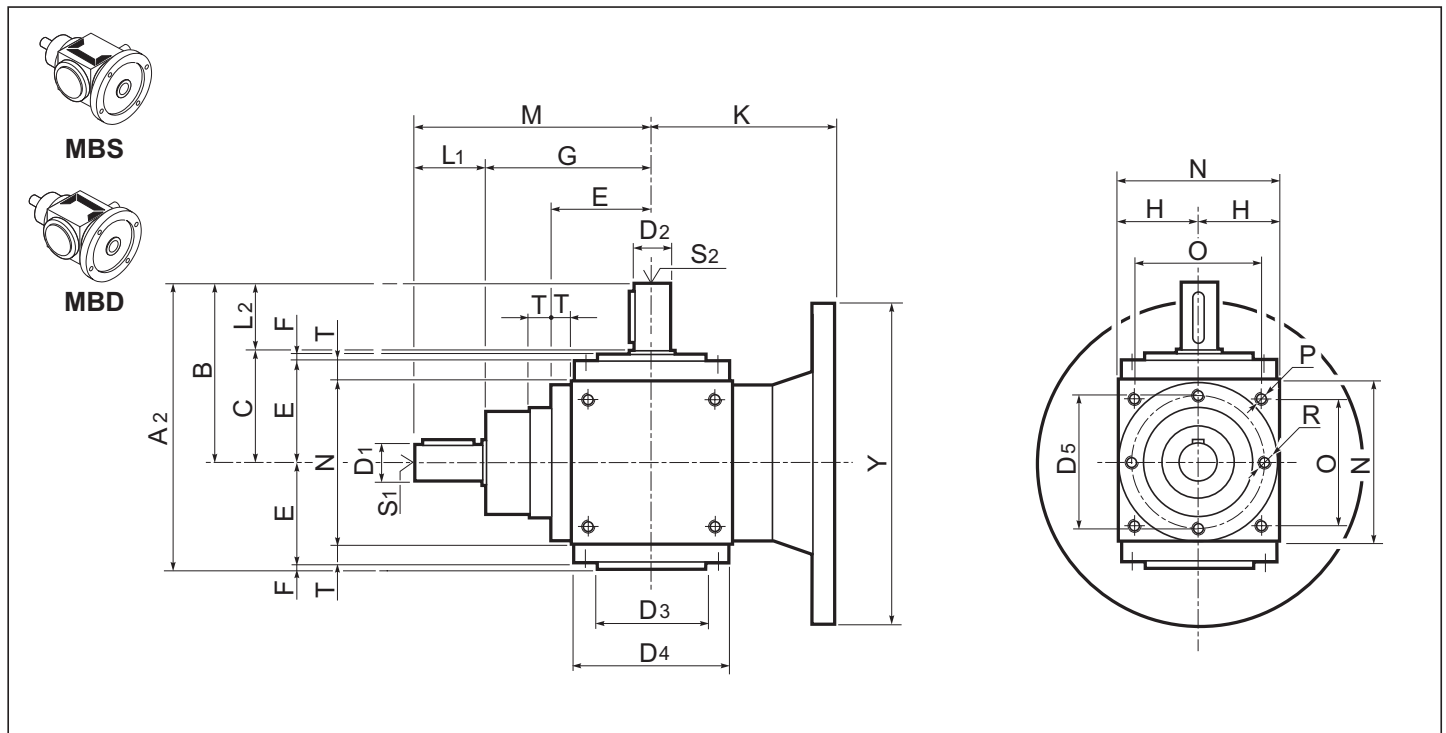



1.8 Dimensioni

1.8 Dimensions

1.8 Abmessungen

Z.BS Z.BD	C	D3 h8	D4	D5	E	F	G	H	N	O	P	R	T
12	46	44	—	54	42	2	74	32.5	65	45	M6	M6	—
19	65	60	86	72	59	4	100	45	90	70	M6	M6	14
24	80	70	105	88	73	5	115	55	110	88	M8	M8	18
32	95	95	135	115	88	5	145	70	140	110	M10	M10	18
38	110	120	165	145	103	5	170	85	170	136	M12	M12	18
42	125	135	190	165	118	5	195	100	200	155	M12	M12	18
55	150	170	230	205	143	5	245	120	240	190	M14	M14	23
75	225	—	300	—	195	—	350	165	330	248	M16	M16	30

Z.BS Z.BD	ir	A1	A2	M	Albero entrata / Input shaft / Antriebswelle			Albero uscita / Output shaft / Abtriebswelle		
					D1 j6	L1	S1	D2 j6	L2	S2
12	1-2-3	200	116	100	12	26	M4x8	12	26	M4x8
19	1-2-3	280	168	140	19	40	M6x12	19	40	M6x12
	4-5	260		130	14	30	M5x10			
24	1-2-3	330	208	165	24	50	M8x16	24	50	M8x16
	4-5	310		155	19	40	M6x12			
32	1-2-3	410	248	205	32	60	M10x20	32	60	M10x20
	4-5	390		195	24	50	M8x16			
38	1-2-3	480	288	240	38	70	M12x24	38	70	M12x24
	4-5	460		230	28	60	M10x20			
42	1-2-3	550	328	275	42	80	M12x24	42	80	M12x24
	4-5	510		255	32	60	M10x20			
55	1-2-3	710	408	355	55	110	M14x28	55	110	M14x28
	4-5	650		325	42	80	M12x24			
75	1-2-3	1000	598	500	75	150	M16x32	75	150	M16x32
	4-5	920		460	55	110	M14x28			

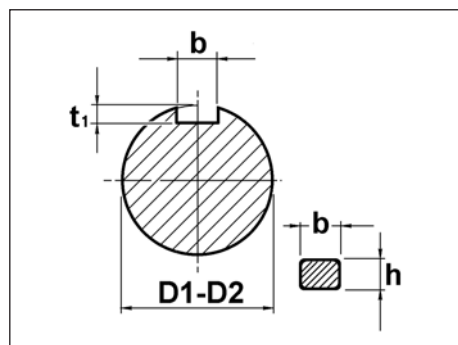

D1 - D2	b x h	t ₁
12	4 x 4	2.5
14	5 x 5	3.0
19	6 x 6	3.5
24	8 x 7	4.0
28	8 x 7	4.0
32	10 x 8	4.0
38	10 x 8	5.0
42	12 x 8	5.0
55	16 x 10	6.0
75	22 x 14	9.0

Z.MBS Z.MBD	IEC	12		19		24		32		38		42		55	
		Y	K	Y	K	Y	K	Y	K	Y	K	Y	K	Y	K
B5	105 (B14)	90	140	90	160	120	200	140	200	155	250	200	250	220	
	140	90	160	90	200	120	250	140	250	155	300	200	300	220	
									300	175	350	200	350	220	

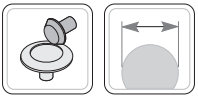

Z.AH

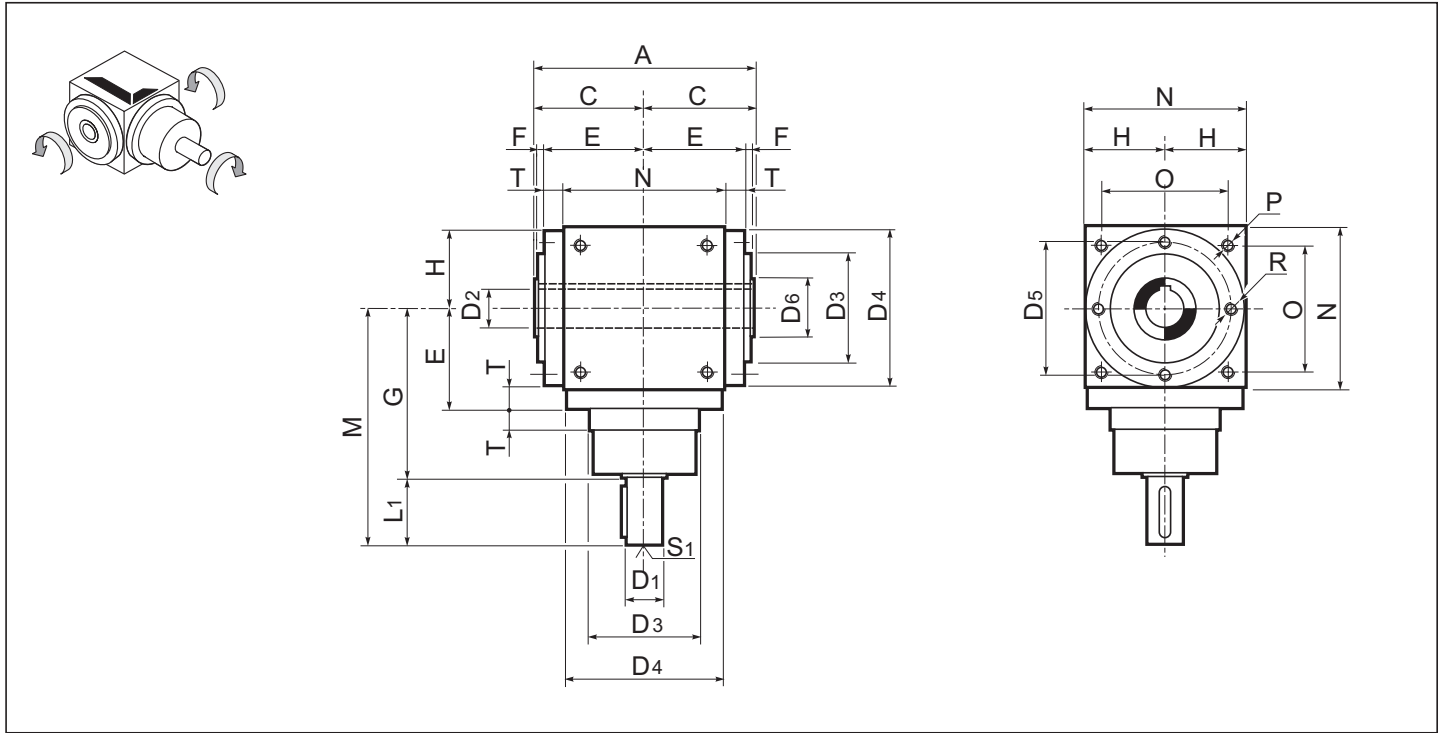

Z.MAH

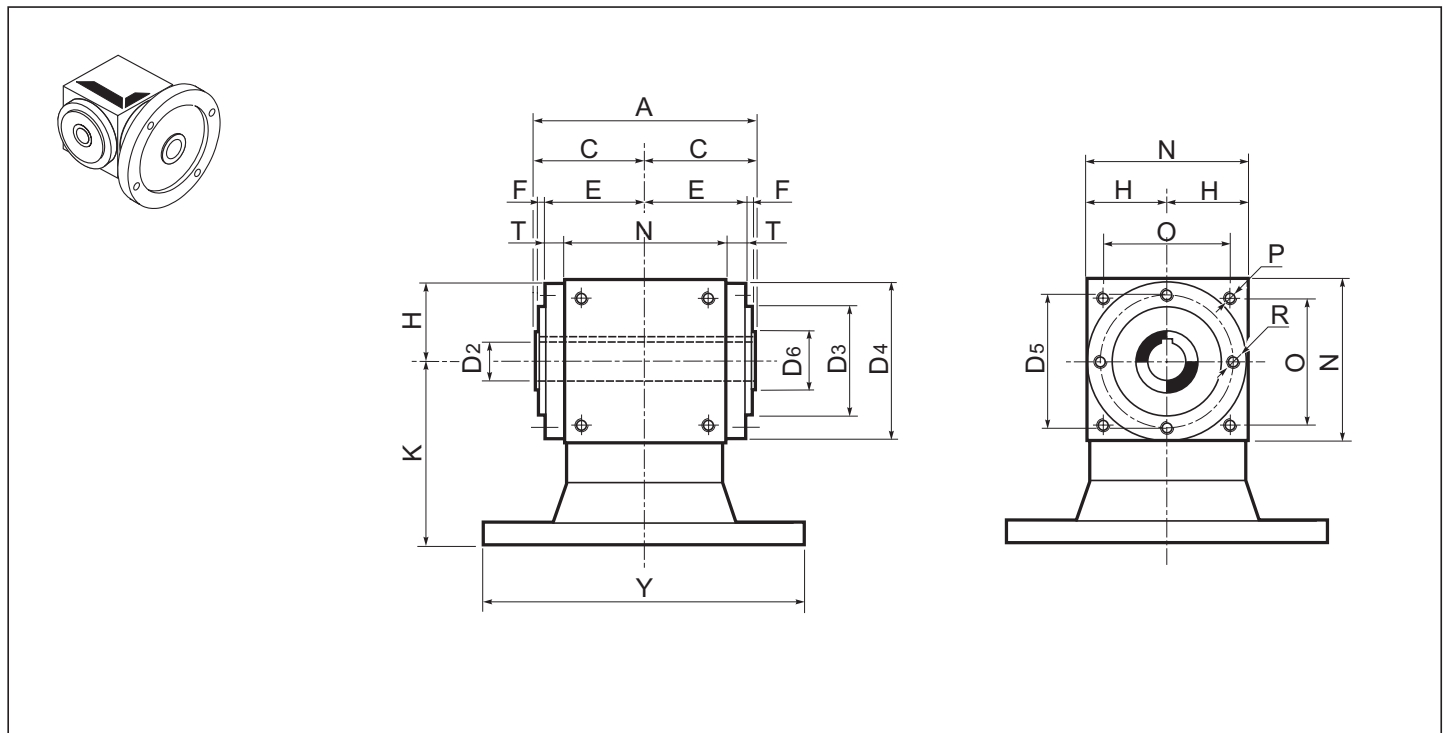

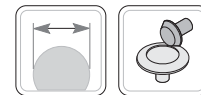

1.8 Dimensioni

1.8 Dimensions

1.8 Abmessungen

Z.AH	C	D3 h8	D4	D5	D6	E	F	G	H	N	O	P	R	T
12	46	44 (h7)	65	54	—	42	2	74	32.5	65	—	—	76	9.5
19	65	60	86	72	30	59	4	100	45	90	70	M6	M6	14
24	80	70	105	88	35	73	5	115	55	110	88	M8	M8	18
32	95	95	135	115	50	88	5	145	70	140	110	M10	M10	18
38	110	120	165	145	60	103	5	170	85	170	136	M12	M12	18
42	125	135	190	165	60	118	5	195	100	200	155	M12	M12	18
55	150	170	230	205	75	143	5	245	120	240	190	M14	M14	23
75	225	—	300	—	120	195	—	350	165	330	248	M16	M16	30

Z.AH	ir	A	M	Albero entrata / Input shaft / Antriebswelle			Albero uscita / Output shaft / Abtriebswelle
				D1 j6	L1	S1	D2 H7
12	1-2-3	92	100	12	26	—	12
19	1-2-3	130	140	19	40	M6x12	19
	4-5		130	14	30	M5x10	
24	1-2-3	160	165	24	50	M8x16	24
	4-5		155	19	40	M6x12	
32	1-2-3	190	205	32	60	M10x20	32
	4-5		195	24	50	M8x16	
38	1-2-3	220	240	38	70	M12x24	38
	4-5		230	28	60	M10x20	
42	1-2-3	250	275	42	80	M12x24	42
	4-5		255	32	60	M10x20	
55	1-2-3	300	355	55	110	M14x28	55
	4-5		325	42	80	M12x24	
75	1-2-3	450	500	75	150	M16x32	75
	4-5		460	55	110	M14x28	

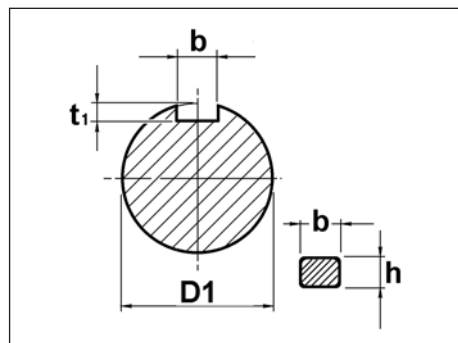

D1	b x h	t ₁
14	5 x 5	3.0 +0.1 0
19	6 x 6	3.5 0
24	8 x 7	4.0
28	8 x 7	4.0
32	10 x 8	4.0
38	10 x 8	5.0 +0.2 0
42	12 x 8	5.0
55	16 x 10	6.0
75	22 x 14	9.0

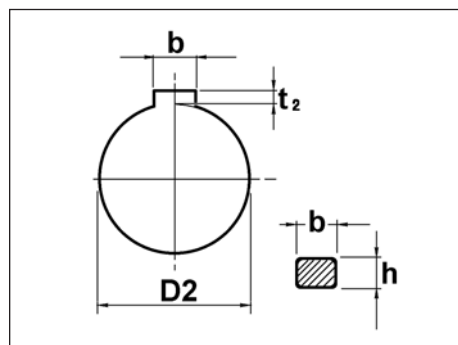

D2	b x h	t ₂
19	6 x 6	2.8 +0.1 0
24	8 x 7	3.3
32	10 x 8	3.3
38	10 x 8	3.3 +0.2 0
42	12 x 8	3.3
55	16 x 10	4.3
75	22 x 14	5.4

Z.MAH	IEC	12		19		24		32		38		42		55	
		Y	K	Y	K	Y	K	Y	K	Y	K	Y	K	Y	K
	B5	105 (B14)	90	140	90	160	120	200	140	200	155	250	200	250	220
		140	90	160	90	200	120	250	140	250	155	300	200	300	220
										300	175	350	200	350	220

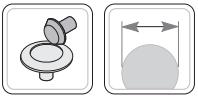

Z.BH

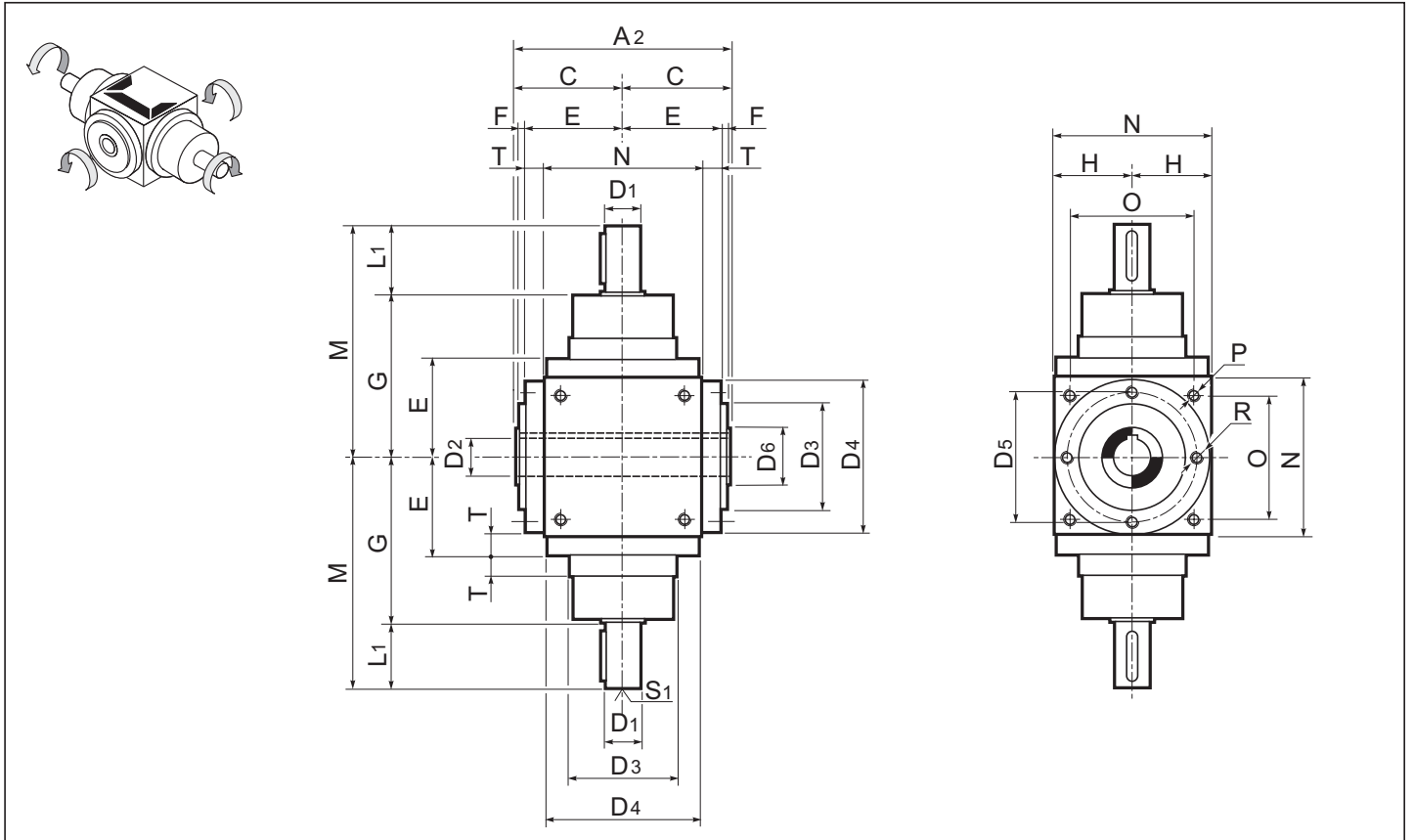

Z.MBH

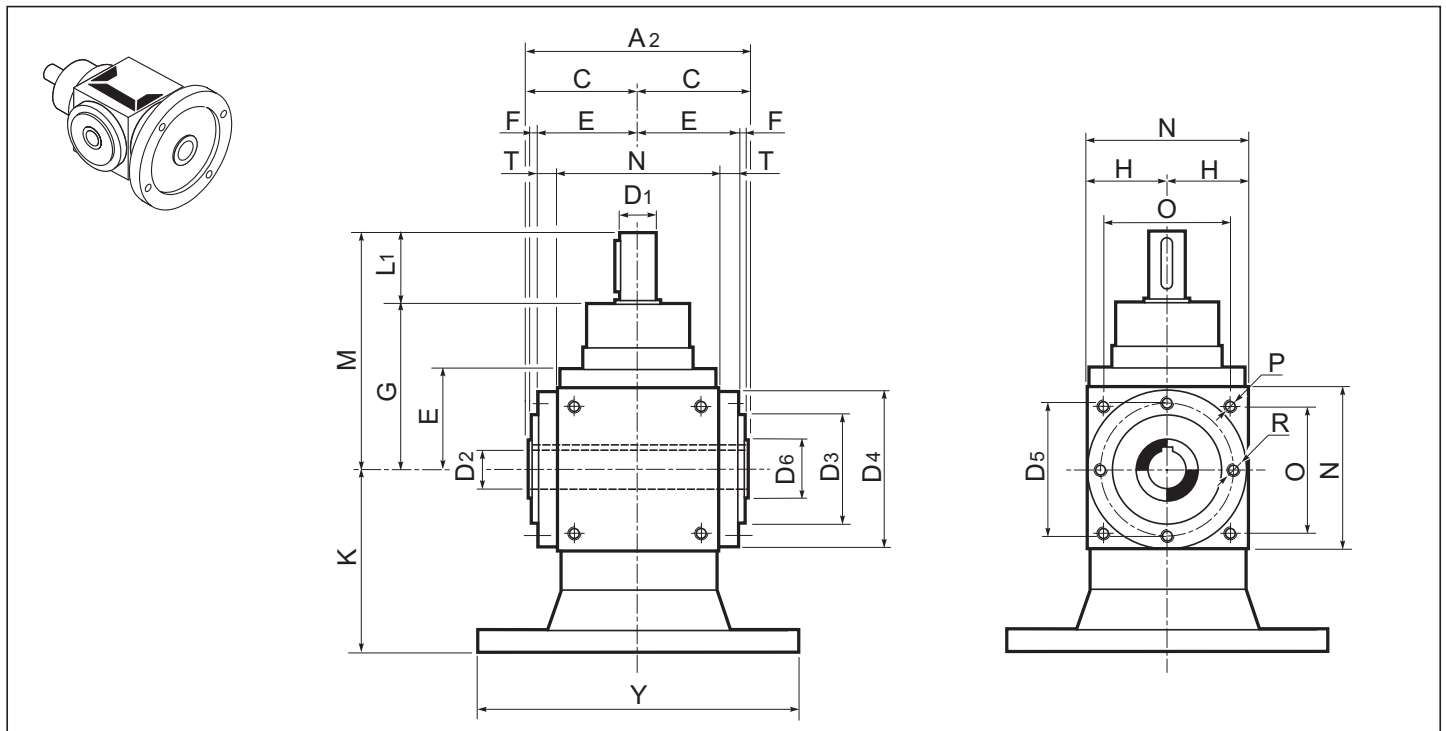



1.8 Dimensioni

1.8 Dimensions

1.8 Abmessungen

Z.BH	C	D3 h8	D4	D5	D6	E	F	G	H	N	O	P	R	T
12	46	44 (h7)	65	54	—	42	2	74	32.5	65	—	—	76	9.5
19	65	60	86	72	30	59	4	100	45	90	70	M6	M6	14
24	80	70	105	88	35	73	5	115	55	110	88	M8	M8	18
32	95	95	135	115	50	88	5	145	70	140	110	M10	M10	18
38	110	120	165	145	60	103	5	170	85	170	136	M12	M12	18
42	125	135	190	165	60	118	5	195	100	200	155	M12	M12	18
55	150	170	230	205	75	143	5	245	120	240	190	M14	M14	23
75	225	—	300	—	120	195	—	350	165	330	248	M16	M16	30

Z.BH	ir	A1	A2	M	Albero entrata / Input shaft / Antriebswelle			Albero uscita / Output shaft / Abtriebswelle
					D1 j6	L1	S1	D2 H7
12	1-2-3	—	—	—	—	—	—	—
19	1-2-3	280	130	140	19	40	M6x12	19
	4-5	260		130	14	30	M5x10	
24	1-2-3	330	160	165	24	50	M8x16	24
	4-5	310		155	19	40	M6x12	
32	1-2-3	410	190	205	32	60	M10x20	32
	4-5	390		195	24	50	M8x16	
38	1-2-3	480	220	240	38	70	M12x24	38
	4-5	460		230	28	60	M10x20	
42	1-2-3	550	250	275	42	80	M12x24	42
	4-5	510		255	32	60	M10x20	
55	1-2-3	710	300	355	55	110	M14x28	55
	4-5	650		325	42	80	M12x24	
75	1-2-3	1000	450	500	75	150	M16x32	75
	4-5	920		460	55	110	M14x28	

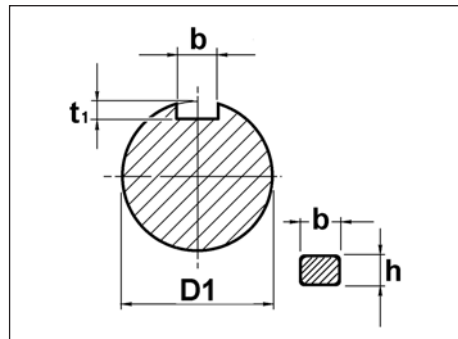

D1	b x h	t ₁
14	5 x 5	3.0 +0.1 0
19	6 x 6	3.5
24	8 x 7	4.0
28	8 x 7	4.0
32	10 x 8	4.0
38	10 x 8	5.0 +0.2 0
42	12 x 8	5.0
55	16 x 10	6.0
75	22 x 14	9.0

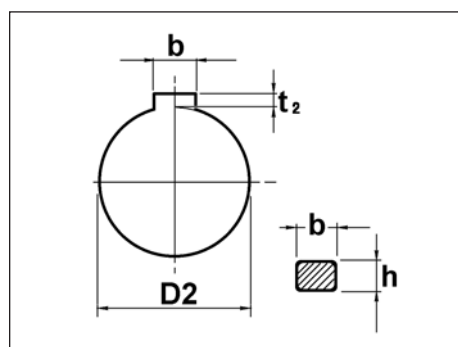

D2	b x h	t ₂
19	6 x 6	2.8 +0.1 0
24	8 x 7	3.3
32	10 x 8	3.3
38	10 x 8	3.3 +0.2 0
42	12 x 8	3.3
55	16 x 10	4.3
75	22 x 14	5.4

Z.MBH	IEC	12		19		24		32		38		42		55	
		Y	K	Y	K	Y	K	Y	K	Y	K	Y	K	Y	K
	B5	105 (B14)	90	140	90	160	120	200	140	200	155	250	200	250	220
		140	90	160	90	200	120	250	140	250	155	300	200	300	220
										300	175	350	200	350	220

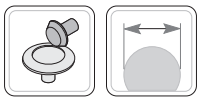

FLANGIA DI ACCOPPIAMENTO FC / FC FLANGE / VERBINDUNGSFLANSCH FC

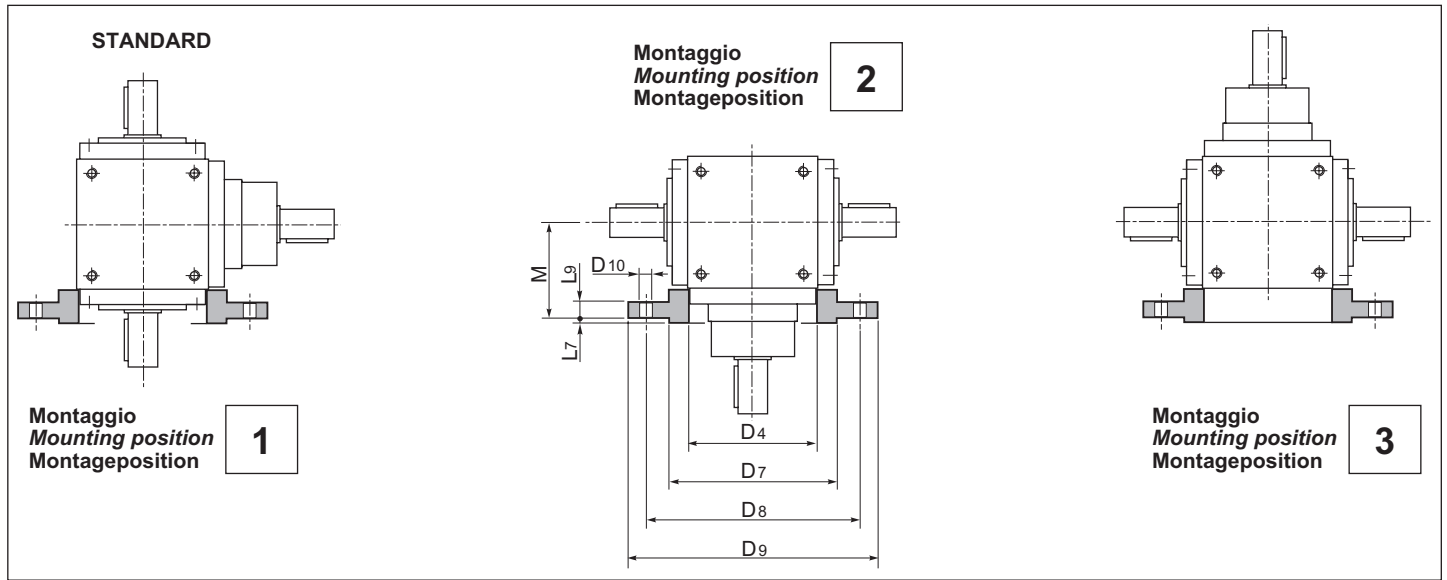

FLANGIA DI ACCOPPIAMENTO FP / FP FLANGE / VERBINDUNGSFLANSCH FP

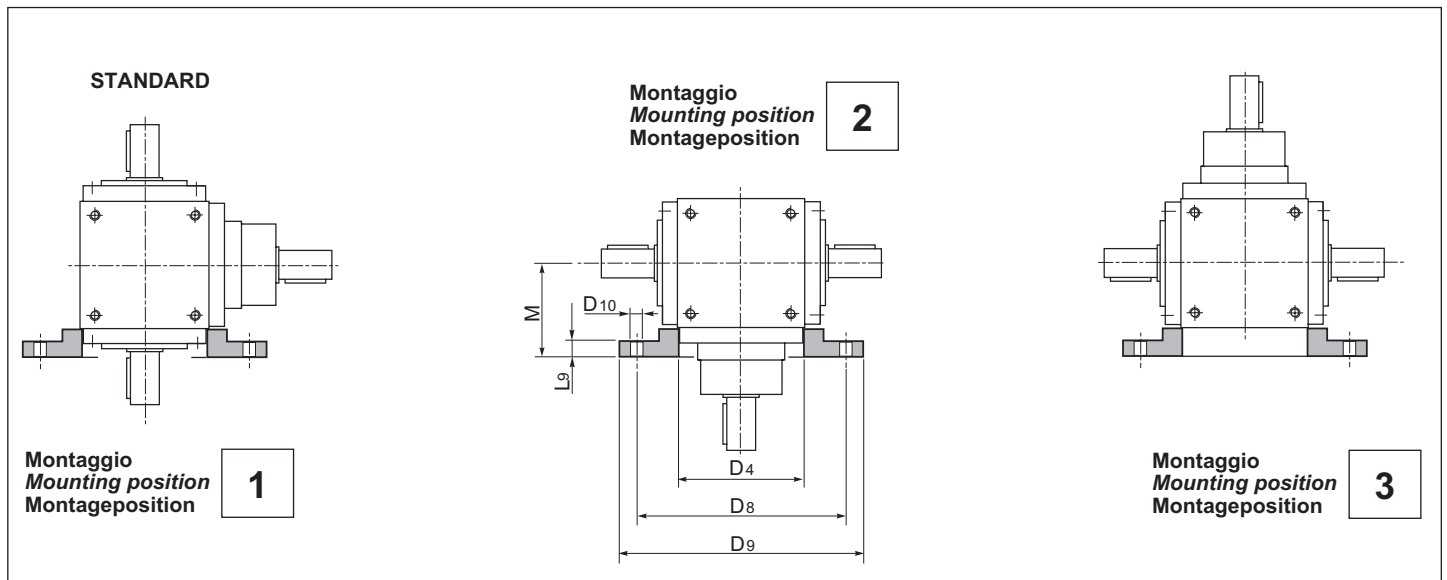

Z.	D4 H8	D7 h8	D8	D9	D10	L7	L9	M
12	—	—	—	—	—	—	—	—
19	86	110	130	160	9	3.5	12	70
24	105	130	165	200	11	3.5	13	85
32	135	180	215	250	14	4	15	105
38	165	230	265	300	14	4	15	125
42	190	230	265	300	14	4	15	145
55	230	250	300	350	18	5	18	175
75	300	350	400	450	18	5	25	230