

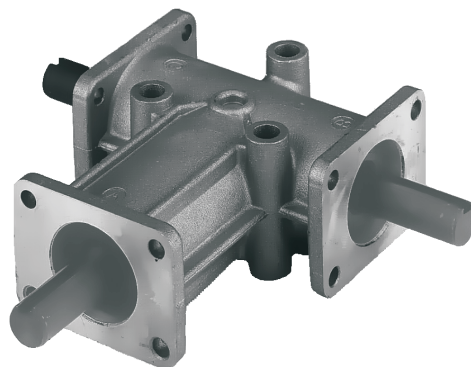

1.0 RINVII ANGOLARI ZL
1.0 RIGHT ANGLE ZL
1.0 WINKELGETRIEBE ZL

ZL

1.1	Caratteristiche tecniche	<i>Technical characteristics</i>	Technische Eigenschaften	F1
1.2	Designazione	<i>Designation</i>	Bezeichnungen	F2
1.3	Versioni	<i>Versions</i>	Ausführungen	F3
1.4	Lubrificazione	<i>Lubrication</i>	Schmierung	F3
1.6	Carichi radiali e assiali	<i>Axial and overhurg loads</i>	Radiale und Axiale Belastungen	F4
1.6	Prestazioni rinvii angolari	<i>Gearmotors performances</i>	Leistungen der Getriebe	F5
1.7	Dimensioni	<i>Dimensions</i>	Abmessungen	F6



1.1 Caratteristiche tecniche

Il nostri rinvii angolari serie ZL, sono molto leggeri ed hanno un funzionamento silenzioso.

Hanno la carcassa monoblocco in alluminio rigida e precisa, gli ingranaggi Gleason ed i cuscinetti largamente dimensionati.

I giochi angolari vanno dai 15' ai 30' e sono sempre forniti con il lubrificante adatto a tutte le posizioni di montaggio.

Sono disponibili con 3 flange di fissaggio, 3 o 4 fori passanti di bloccaggio sul corpo, 2 o 3 alberi e rapporti di riduzione 1-2-3.

1.1 Technical characteristics

Our right angle gears ZL series are not heavy and are silent functioning.

The one body piece in aluminium is strong, the gears are Gleason and the bearings are overrated as well.

The backlash is 15'-30' and they are filled with lubricant for all the mounting positions.

These right angle gears are available with 3 fixing flange, 3 or 4 locking through holes on the body, 2 or 3 shaft and ratio 1-2-3.

1.1 Technische Eigenschaften

Die Winkelgetriebe der ZL-Serie zeichnen sich durch geringes Gewicht und hohe Laufruhe aus.

Das Monoblockgehäuse ist äußerst stabil und präzise gefertigt; die Gleason-Zahnräder sowie die Lager sind großzügig dimensioniert.

Das Flankenspiel liegt im Bereich 15' - 30' und die Ölfüllung erfolgt gemäß der Einbaulage.

Zur Lieferung stehen drei mögliche Flansche zur Verfügung; drei oder vier Durchgangsbohrungen für die Gehäusebefestigung, zwei oder drei Wellen und Untersetzungen 1-2-3.



1.1 Caratteristiche tecniche

I rinvii angolari serie **ZL** sono stati progettati per applicazioni industriali ove occorra trasmettere un moto rotatorio di potenza tra alberi disposti perpendicolarmente tra loro. Possono essere a 3 uscite con rapporto di trasmissione:1:1 o 2:1.

Carte

Monoblocco rigido in lega d'alluminio con 5 piani di attacco e 3 possibilità di centraggio.

Ingranaggi

Conici a dentatura spiroidale GLEASON. Il gioco angolare fra gli ingranaggi è regolato per garantire un ingranamento ed una silenziosità ottimali.

Alberi

L'attacco esterno è previsto con un trascinamento a linguetta a norma UNI (ad eccezione della grandezza 331). Le posizioni angolari delle linguette sugli alberi entrata e uscita non hanno particolari riferimenti tra loro.

Cuscinetti

Sono a sfere, largamente dimensionati e a gola profonda.

Tenute lubrificante interno

Con anelli di tenuta su tutti i modelli. A richiesta sono disponibili anelli speciali per alte o basse temperature.

1.1 Technical characteristics

ZL Series right-angle drives are designed for industrial applications where rotary power must be transferred between two shafts at right-angles to each other. ZL series units are available in 6 different sizes with 3 outputs and with 1:1 or 1:2 transmission ratios.

Housing

Single-piece aluminium alloy casting with 5 mounting points and 3 flanges.

Gears

GLEASON spiral toothed bevel gears. Units are manufactured with a backlash tolerance to ensure perfect gear meshing and silent operation.

Shafts

Coupling to external power take-off is by ISO standard driving keys (except for size 331). No special position references are needed for the Keyways on input and output shafts, which can therefore be made at any angle.

Bearings

Large bearings in deep races.

Oilseals

Oilseal rings are fitted to all models. Special seal rings for high or low temperatures are available upon request.

1.1 Technische Eigenschaften

Die Winkelgetriebe der Serie **ZL** sind für den industriellen Einsatz geeignet, wenn die Drehbewegung um 90° umgelenkt werden muss. Die Getriebe sind mit 3 Wellenenden ausgerüstet und können mit Untersetzungsverhältnis 1:1 bzw. 1:2 geliefert werden.

Gehäuse

Starres Getriebegehäuse aus Leichtmetall; 5 Befestigungsflächen und 3 Zentrierlagen.

Verzahnung

Kegelradgetriebe mit Schrägverzahnung GLEASON. Das Zahnflankenspiel zwischen den Rädern gewährleistet optimale Eingriffseigenschaften und eine hohe Laufruhe.

Wellen

Die Kopplung der Abtriebswelle erfolgt mit Paßfeder gemäß der UNI-Norm (Mit Ausnahme der Baugröße 331. Die Winkelpositionen der Paßfedern auf den Antriebs- und Abtriebswellen sind voneinander unabhängig.

Lager

Großzügig dimensionierte Kugellager mit tiefer Laufrille.

Dichtungen

Sämtliche Typen sind mit Dichtringen versehen. Auf Anfrage sind Spezialdichtringe für hohe bzw. niedrige Temperaturen lieferbar.

1.2 Designazione

1.2 Designation

1.2 Bezeichnung

ZL	Grand. Size Größe		Posizione alberi Shafts position Wellenposition	ir	Esempio / Example Beispiel ZL 331 BC 1.1
	331	432	AB	1.1	
	332	433	AC	2.1	
	333	434	BC		
	334				

1.3 Versioni

1.3 Versions

1.3 Ausführung

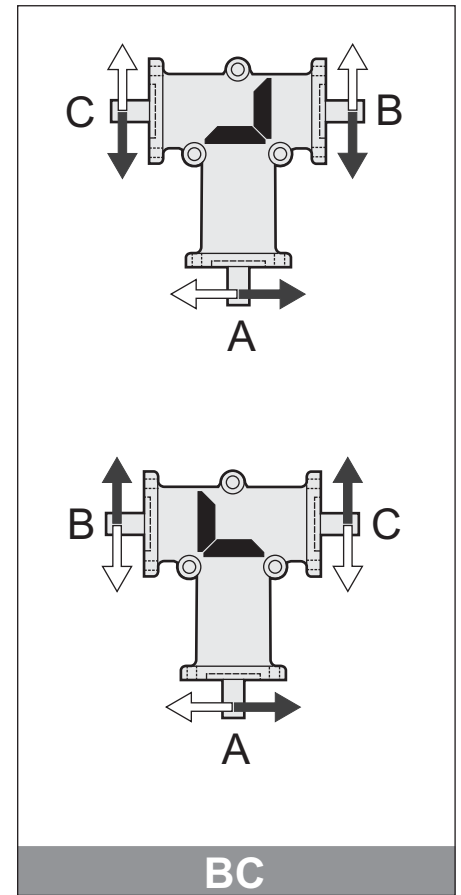
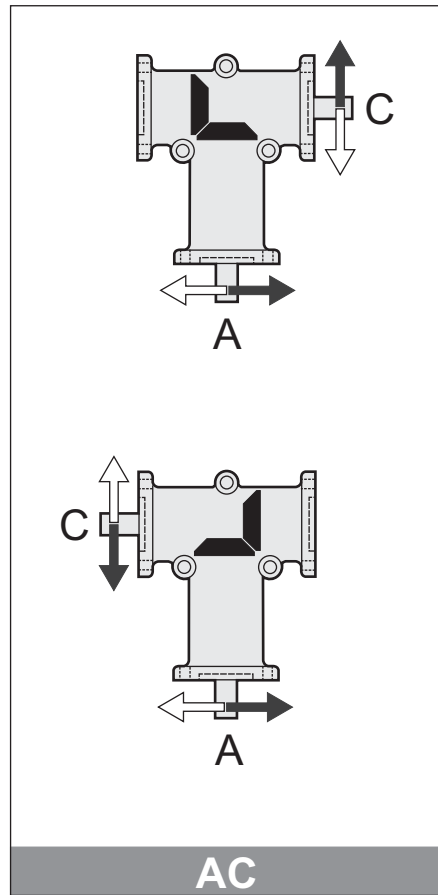
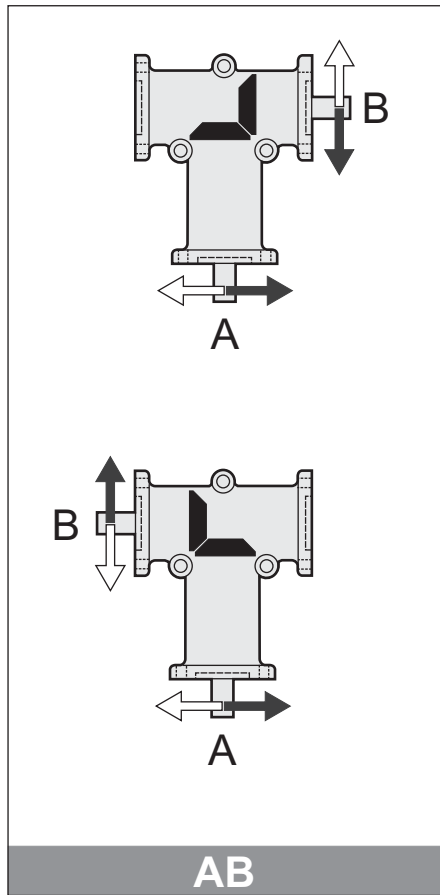

- A = albero entrata
- B = albero uscita lato corona conica
- C = albero uscita lato opposto alla corona conica

- A = *Input shaft*
- B = *Output shaft on ring bevel gear side*
- C = *Output shaft on opposite side to ring bevel gear*

- A = Antriebswelle
- B = Abtriebswelle Seite Kegelkranz
- C = Abtriebswelle auf der gegenüberliegenden Seite des Kegelkranzes

Le figure mostrano, per ogni versione, i sensi di rotazione degli alberi. Per ogni versione, lo stesso rinvio è rappresentato in due posizioni ruotate di 180°.

For each version, the figures will show the shaft directions of rotation. For each version, the same transmission is shown in two positions turned by 180°.

Die Abbildungen zeigen für jede Version die entsprechende Drehrichtung der Wellen. Für jede Version wird das gleiche Getriebe in zwei, jeweils um 180° versetzten Positionen dargestellt.

(1) **ATTENZIONE!-WARNING!-ACHTUNG!** ()/(/()

1.4 Lubrificazione

Vedere paragrafo 1.12 Sezione A

1.4 Lubrication

Look at chapter 1.12 Section A.

1.4 Schmierung

s. S. 1.12-Abschnitt A.



1.5 Carichi radiali e assiali

Le trasmissioni effettuate tramite pignoni per catena, ruote dentate o pulegge generano delle forze radiali (F_r) sugli alberi dei riduttori. I valori dei carichi radiali e assiali generati dall'applicazione debbono essere sempre minori o uguali a quelli ammissibili indicati nelle tabelle.

1.5 Radial and axial loads

Transmissions implemented by means of chain pinions, gears or pulleys generate radial forces (F_r) on the gear unit shafts. The value of the radial and axial loads generated by the application must always be less than or equal to admissible values as indicated in the chart.

1.5 Radial und axial Belastungen (N)

Antriebe mit Kettenrädern, Zahnrädern oder Riemenscheiben erzeugen radiale Kräfte (F_r) an den Wellen der Untersetzungsgetriebe. Die Werte der Quer- und Längsbelastungen, die durch die Anwendungen hervorgerufen werden, dürfen nicht über den den in den Tabellen angegebenen zulässigen Werten liegen.

Tab. 5.1

i	$F_{r1} = F_{r2}$ [N]						
	ZL 331	ZL 332	ZL 333	ZL 334	ZL 432	ZL 433	ZL 434
Tutti /All / Alle	210	410	760	880	530	650	800

i	$F_{a1} = F_{a2}$ [N]						
	ZL 331	ZL 332	ZL 333	ZL 334	ZL 432	ZL 433	ZL 434
Tutti /All / Alle	110	200	430	490	300	450	600

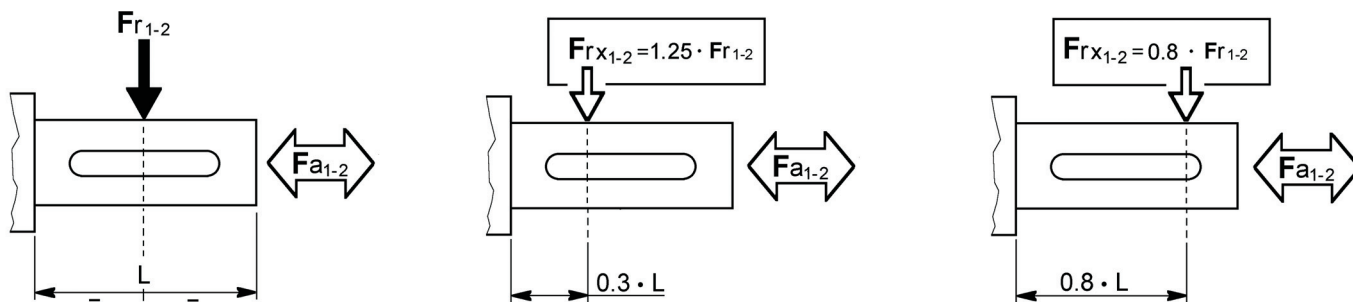

I carichi radiali indicati nelle tabelle si intendono applicati a metà della sporgenza dell'albero standard e sono riferiti ai riduttori operanti con fattore di servizio 1. Per i carichi non agenti sulla mezzeria dell'albero lento o veloce si ha:

- a 0.3 della sporgenza:
 $F_{rx} = 1.25 \times F_{r1-2}$
- a 0.8 dalla sporgenza:
 $F_{rx} = 0.8 \times F_{r1-2}$

The radial loads shown in the tables are applied on the centre line of the standard shaft extension and are related to gearboxes working with service factor 1. For loads which are not applied on the centre line of the output or input shaft, following values will be obtained:

- at 0.3 from extension:
 $F_{rx} = 1.25 \times F_{r1-2}$
- at 0.8 from extension:
 $F_{rx} = 0.8 \times F_{r1-2}$

Bei den in der Tabelle angegebenen Radialbelastungen wird eine Krafteinwirkung auf die Mitte des Wellenendes zugrunde gelegt; außerdem arbeiten die Getriebe mit Betriebsfaktor 1. Bei Lasten, die nicht auf die Mitte der Ab- und Antriebswellen wirken, legt man folgende Werte zugrunde:

- 0.3 vom Wellenabsatz entfernt:
 $F_{rx} = 1.25 \times F_{r1-2}$
- 0.8 vom Wellenabsatz entfernt:
 $F_{rx} = 0.8 \times F_{r1-2}$

1.6 Prestazioni riduttori ZL

1.6 ZL gearboxes performances

1.6 Leistungen der ZL-Getriebe

ZL 331

ir	$n_1 = 2800 \text{ min}^{-1}$				$n_1 = 1400 \text{ min}^{-1}$				$n_1 = 900 \text{ min}^{-1}$				$n_1 = 500 \text{ min}^{-1}$				Kg
	n_2 min ⁻¹	T_{2M} Nm	P kW	RD %	n_2 min ⁻¹	T_{2M} Nm	P kW	RD %	n_2 min ⁻¹	T_{2M} Nm	P kW	RD %	n_2 min ⁻¹	T_{2M} Nm	P kW	RD %	
1	2800	2.0	0.63	95	1400	2.4	0.37	95	900	2.6	0.26	95	500	2.9	0.16	95	0.3
2	—	—	—	—	700	1.1	0.08	95	450	1.2	0.06	95	250	1.3	0.04	95	

ZL 332

ir	$n_1 = 2800 \text{ min}^{-1}$				$n_1 = 1400 \text{ min}^{-1}$				$n_1 = 900 \text{ min}^{-1}$				$n_1 = 500 \text{ min}^{-1}$				Kg
	n_2 min ⁻¹	T_{2M} Nm	P kW	RD %	n_2 min ⁻¹	T_{2M} Nm	P kW	RD %	n_2 min ⁻¹	T_{2M} Nm	P kW	RD %	n_2 min ⁻¹	T_{2M} Nm	P kW	RD %	
1	2800	7.7	2	95	1400	8.6	1.3	95	900	9.2	0.91	95	500	10.0	0.55	95	1.2
2	—	—	—	—	700	5.0	0.39	95	450	5.3	0.26	95	250	5.6	0.15	95	

ZL 333

ir	$n_1 = 2800 \text{ min}^{-1}$				$n_1 = 1400 \text{ min}^{-1}$				$n_1 = 900 \text{ min}^{-1}$				$n_1 = 500 \text{ min}^{-1}$				Kg
	n_2 min ⁻¹	T_{2M} Nm	P kW	RD %	n_2 min ⁻¹	T_{2M} Nm	P kW	RD %	n_2 min ⁻¹	T_{2M} Nm	P kW	RD %	n_2 min ⁻¹	T_{2M} Nm	P kW	RD %	
1	2800	20	10.2	95	1400	25	3.9	95	900	27	2.7	95	500	30	1.6	95	3.5
2	—	—	—	—	700	21	1.6	95	450	22	1.1	95	250	23	0.63	95	

ZL 334

ir	$n_1 = 2800 \text{ min}^{-1}$				$n_1 = 1400 \text{ min}^{-1}$				$n_1 = 900 \text{ min}^{-1}$				$n_1 = 500 \text{ min}^{-1}$				Kg
	n_2 min ⁻¹	T_{2M} Nm	P kW	RD %	n_2 min ⁻¹	T_{2M} Nm	P kW	RD %	n_2 min ⁻¹	T_{2M} Nm	P kW	RD %	n_2 min ⁻¹	T_{2M} Nm	P kW	RD %	
1	2800	33	10.2	95	1400	42	6.5	95	900	46	4.6	95	500	53	2.9	95	5.7
2	—	—	—	—	700	37	2.9	95	450	39	1.9	95	250	41	1.1	95	

ZL 432

ir	$n_1 = 2800 \text{ min}^{-1}$				$n_1 = 1400 \text{ min}^{-1}$				$n_1 = 900 \text{ min}^{-1}$				$n_1 = 500 \text{ min}^{-1}$				Kg
	n_2 min ⁻¹	T_{2M} Nm	P kW	RD %	n_2 min ⁻¹	T_{2M} Nm	P kW	RD %	n_2 min ⁻¹	T_{2M} Nm	P kW	RD %	n_2 min ⁻¹	T_{2M} Nm	P kW	RD %	
1	2800	5.7	1.8	95	1400	8.4	1.3	95	900	8.9	0.88	95	500	12.4	0.68	95	2.0
2	—	—	—	—	700	10.2	0.79	95	450	11.5	0.57	95	250	13.9	0.38	95	

ZL 433 - ZL 434

ir	$n_1 = 2800 \text{ min}^{-1}$				$n_1 = 1400 \text{ min}^{-1}$				$n_1 = 900 \text{ min}^{-1}$				$n_1 = 500 \text{ min}^{-1}$				Kg
	n_2 min ⁻¹	T_{2M} Nm	P kW	RD %	n_2 min ⁻¹	T_{2M} Nm	P kW	RD %	n_2 min ⁻¹	T_{2M} Nm	P kW	RD %	n_2 min ⁻¹	T_{2M} Nm	P kW	RD %	
1	2800	15.3	4.7	95	1400	21.7	3.4	95	900	25.1	2.5	95	500	31	1.7	95	4.5
2	—	—	—	—	700	24.7	1.9	95	450	26	1.3	95	250	29.6	0.82	95	

N.B.
Nel caso del rapporto ir = 2 non usare il rinvio in moltiplicazione (cioè entrando dall'albero B o C) oltre 700 giri al minuto.

N.B.
If you require a ir ratio = 2, do not use a speed multiplier (i.e. with inputs on shaft B or C) which operates at more than 700 rpm.

N.B.
Falls die Getriebe als Übersetzungsgetriebe (ins Schnelle) verwendet werden sollen, ist darauf zu achten, dass die Antriebsdrehzahl an der welle B oder C 700 Upm nicht überschreiten darf.



ZL 331

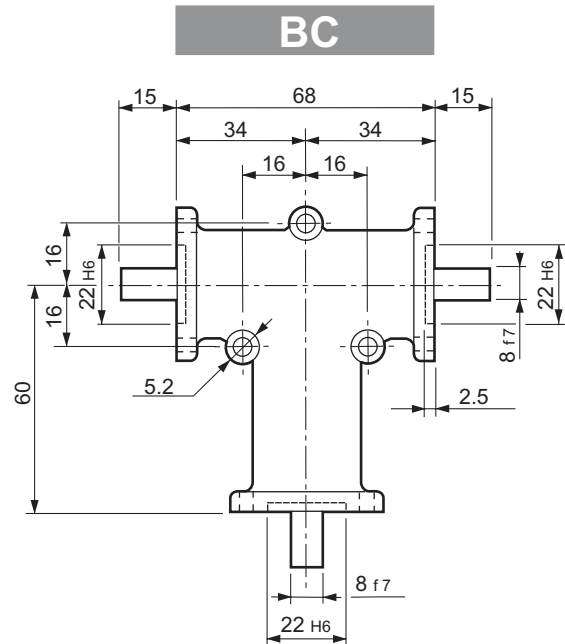
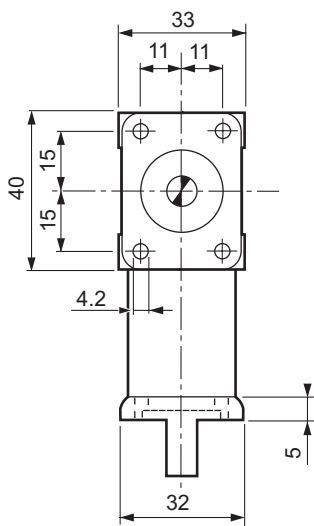
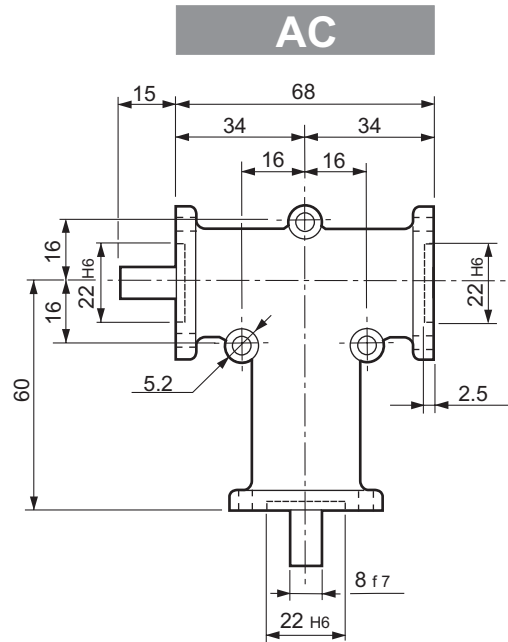
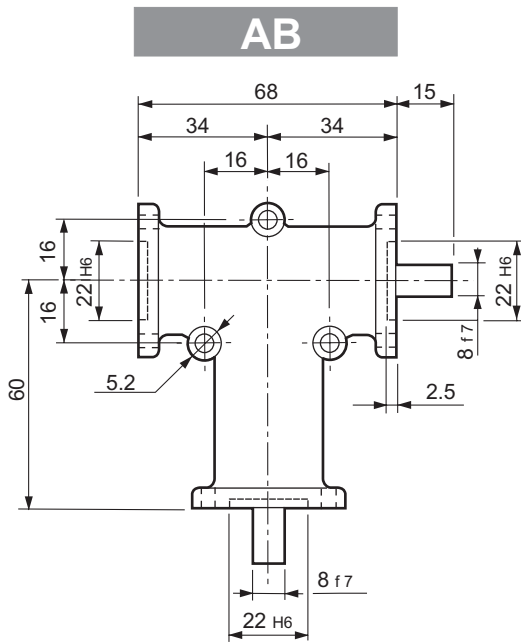

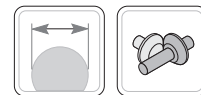

ZL 332 - ZL 333 - ZL 334

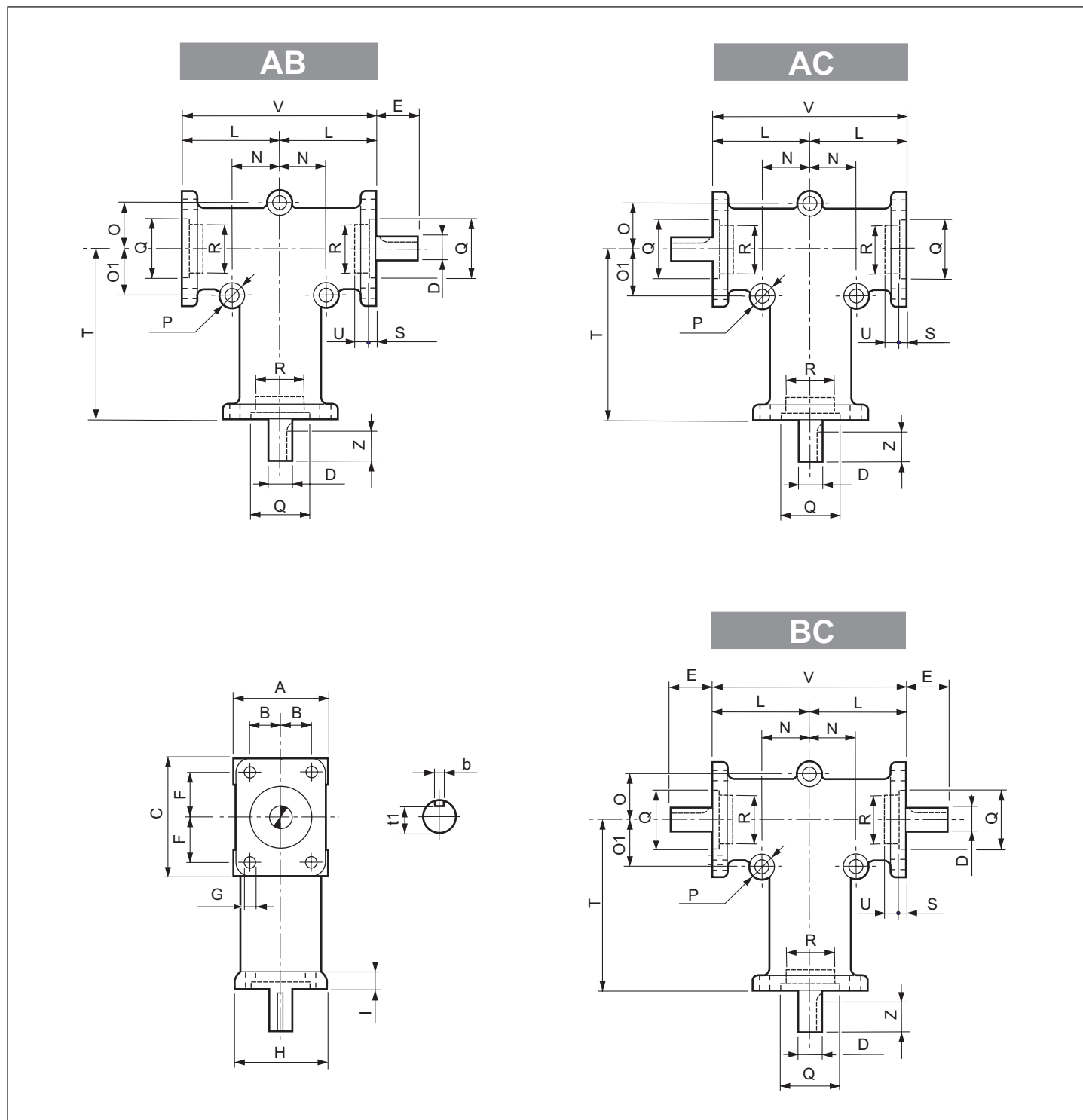

	A	B	C	D f7	b	t1	E	F	G	H	I	L	N	O	O1	P	Q H6	R H6	S	T	U	V	Z
ZL 332	52	18	66	15	5	12	35	26	6.2	50	7	52	24	24	24	8.3	35	-	5	90	-	104	27
ZL 333	76	27	96	20	6	16.5	50	38	8.3	74	8	75	38	38	38	8.3	55	52	3.5	140	5	150	40
ZL 334	100	38	98	25	8	21	70	38	10.3	98	13	80	45	45	70	10.3	65	62	3.5	150	2	160	60

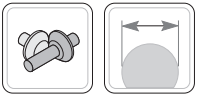

ZL 432

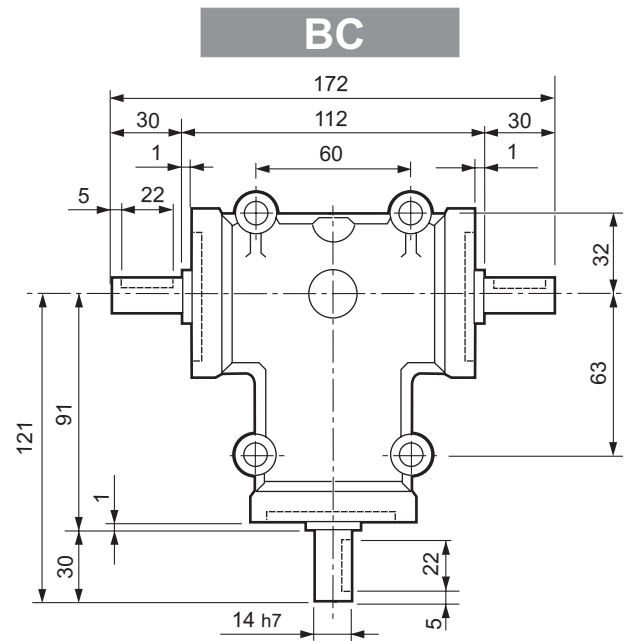
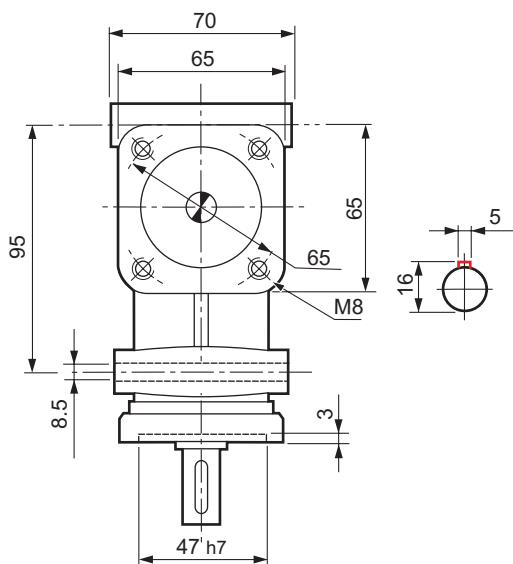
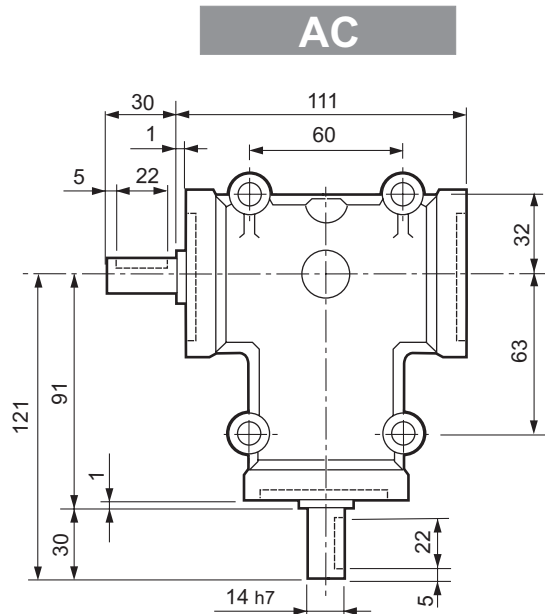
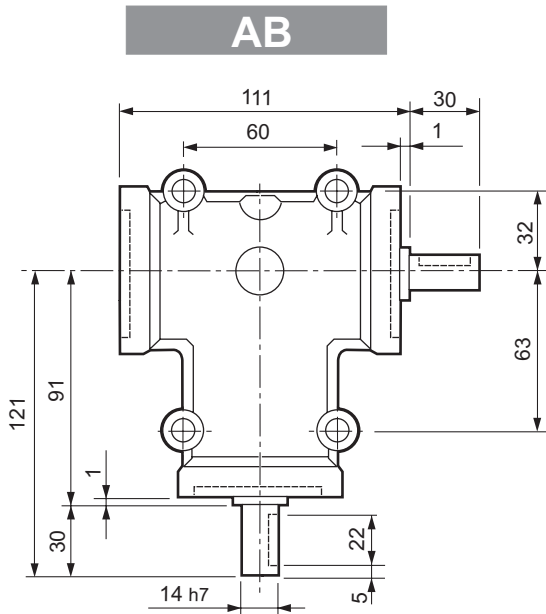

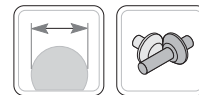

ZL 433 - ZL 434

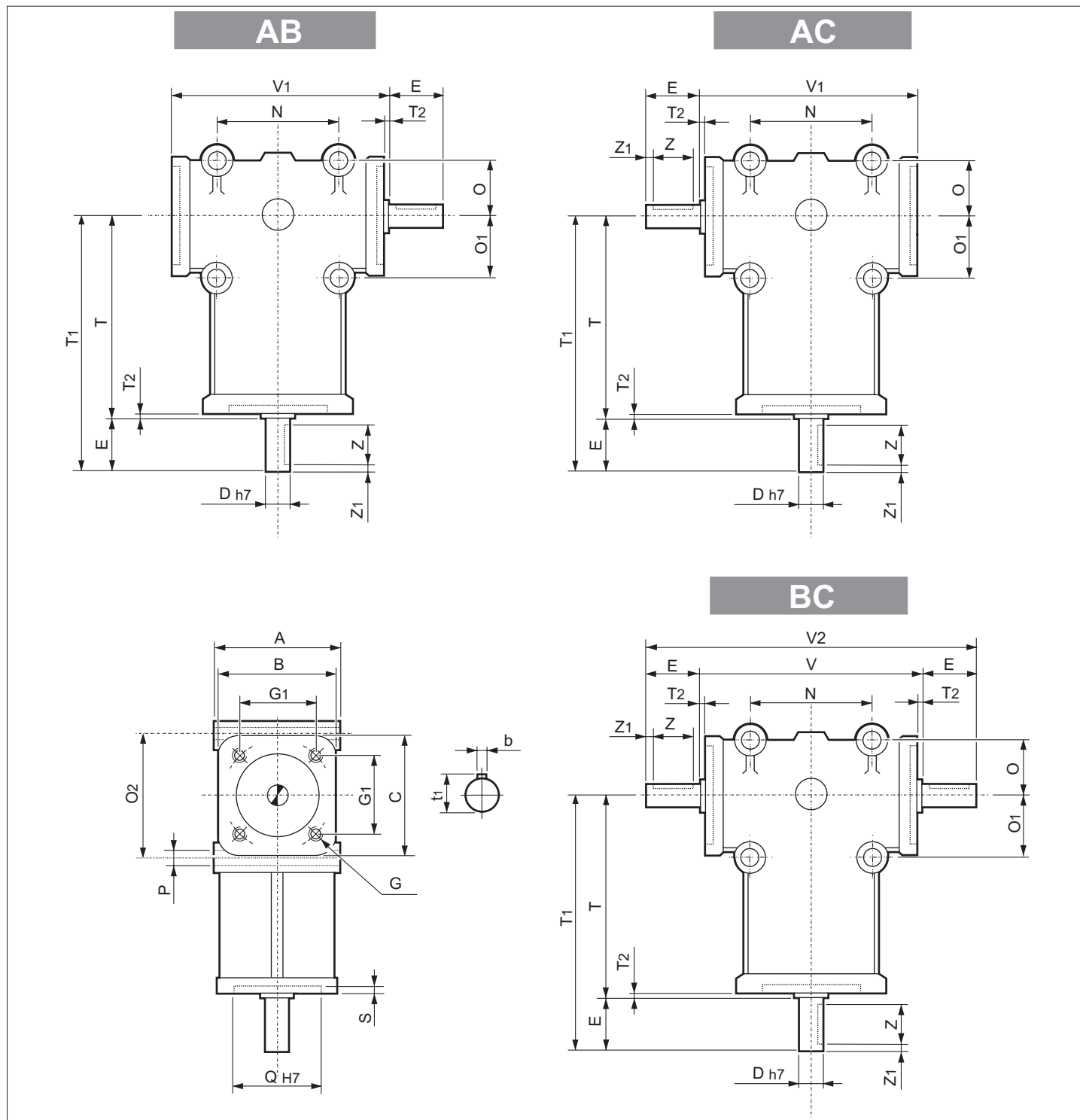

	A	B	C	D f7	E	G	G1	N	O	O1	O2	P	Q H6	S	T	T1	T2	V	V1	V2	Z	Z1	b	t1
ZL 433	86	84	84	19	40	M10	60	86	43	43	86	11	62	5	141	181		152	151	232	30	5	6	21.5
ZL 434				24	50										141	191	1						8	27

