



1.0 RENVOIS D'ANGLE Z
1.0 REENVÍOS ANGULARES Z
1.0 DESVIOS ANGULARES Z

Z

1.1	Caractéristiques techniques	Características técnicas	Características técnicas	E1
1.2	Dénomination	Designación	Designação	E2
1.3	Versions	Versiónes	Versões	E2
1.4	Lubrification	Lubricación	Lubrificação	E5
1.5	Charges radiales et axiales	Charges radiales et axiales	Cargas radiais e axiais	E6
1.6	Couple maximal transmissible pour accouplements en série	Par máximo transmissible para acoplamientos en serie	Torque máxima transmissível para acoplamentos em série	E7
1.7	Performances renvois d'angle Z	Prestaciones reenvíos angulares Z	Desempenhos desvios angulares Z	E8
1.8	Dimensions	Dimensiones	Dimensões	E12
1.9	Accessoires	Accesorios	Acessórios	E34



1.1 Caractéristiques techniques

Le produit se caractérise par un rapport puissance / encombrement avantageux et la possibilité d'un fonctionnement silencieux et régulier même à des vitesses élevées.

Carcasse monobloc en fonte usinée sur toutes les faces, engrenages Gleason et roulements largement dimensionnés.

Le dessin modulaire de nos renvois d'angle Z permet d'équiper le groupe d'arbres supplémentaires, jusqu'à un maximum de 6 (à l'exception du rapport 1/1).

Toutes ces caractéristiques en font un produit qui se situe parmi les premiers de sa catégorie.

1.1 Características técnicas

El producto se distingue por la favorable relación entre potencia y espacio, así como por la posibilidad de funcionamiento regular y silencioso incluso a altas velocidades.

Cuenta con una carcasa monobloque de hierro fundido mecanizado en todas sus caras, engranajes Gleason y cojinetes anchos de gran tamaño.

El diseño modular de nuestro reenvíos angulares Z permite equipar el grupo con ejes suplementarios hasta un máximo de 6 (excepto para la relación 1/1).

Todas estas características hacen de nuestros productos los mejores en su clase.

1.1 Características técnicas

O produto caracteriza-se pela favorável relação potência/dimensões e pela possibilidade de funcionamento silencioso e regular, mesmo em velocidades elevadas.

Carcasa monobloco de liga usinada em todas as faces, engrenagens Gleason e rolamentos amplamente dimensionados.

O desenho modular dos nossos reenvios angulares Z permite equipar o grupo com eixos suplementares, até um máximo de 6 (exceto para a relação 1/1).

Todas estas características tornam o nosso produto o melhor da categoria.



1.2 Dénomination

1.2 Designación

1.2 Designação

Grandeur Medida Dimensão	Version Versión Versão	ir	IEC (B5)	Bride côté sortie Brida salida Flange saída	Entrée Supplémentaire Entrada Suplementaria Entrada suplementar	Exemple / Ejemplo / Exemplo
Z 12 19 24 32 38 42 55 75	A-AS-AD-AP C-DR-B-BS BD-AH-BH AX-DX*	1-1.5-2-3-4-5		FC 1 FC 2 FC 3 FP 1 FP 2 FP 3	A 90-A 180-A 270 AS 90-AS 180-AS 270 AD 90-AD 180-AD 270 C 90 DR 90 H 90-AH 180-AH 270	Z19 A 1.5 FC 1 A 90
	MA-MAS-MAD MC-MDR-MB MBS-MBD MAH-MBH	1-1.5-2-3-4-5	63 160		(pas applicables avec ir=1) (no se pueden aplicar con ir=1) (não aplicáveis com ir=1)	Z19 MA 1.5 PAM 80 FC 1



* Version multiplicateur / * Versión multiplicador / * Versão com multiplicador

Autres spécifications:

Position de la plaque à bornes du moteur si différente de celle standard (1)
Position de montage avec indication bouchons de niveau et remplissage ; sauf indication contraire, la position M1 est à considérer standard

Otras especificaciones:

Posición de la caja de bornes del motor si es distinta de la estándar (1)
Posición de montaje con indicación tapones de nivel y carga; si no se especifica, se considera estándar la posición M1

Outras especificações:

Posição do terminal conector do motor caso diversa da standard (1).
Posição de montagem com indicação tampões de nível e carga; caso não indicado considere standard a posição M1.

1.3 Versions

1.3 Versiones

1.3 Versões

Grandeur / Medida / Dimensão: 12-19-24-32-38-42-55-75, i = 1-1.5-2-3-4-5

A

MA

A90

A180

A270

Grandeur / Medida / Dimensão: 12-19-24-32-38-42-55-75, i = 1-1.5-2-3-4-5

AS

MAS

AS90

AS180

AS270

1.3 Versions

1.3 Versiones

1.3 Versões

Grandeur / Medida / Dimensão: 12-19-24-32-38-42-55-75, i = 1-1.5-2-3-4-5

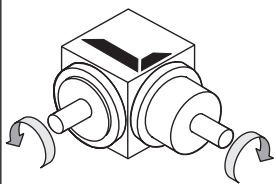

AD

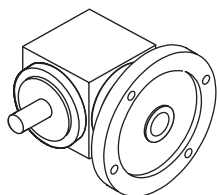

MAD

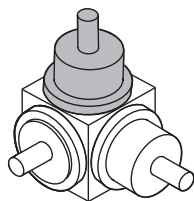

AD90

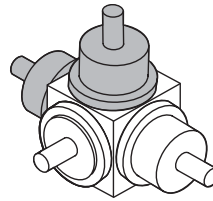

AD180

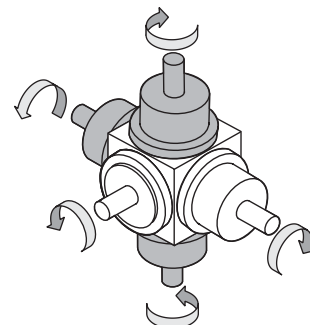

AD270

Grandeur / Medida / Dimensão: 19-24-32-38-42-55-75, i = 1.5-2

Version multiplicateur / Versión multiplicador / Versão com multiplicador

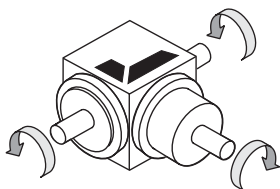

AX

Grandeur / Medida / Dimensão: 12-19-24-32-38-42-55-75, i = 1-1.5-2-3-4-5

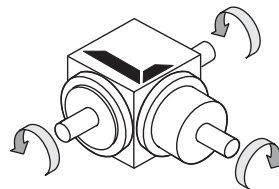

AP

Grandeur / Medida / Dimensão: 12-19-24-32-38-42-55-75, i = 1-1.5-2-3-4-5

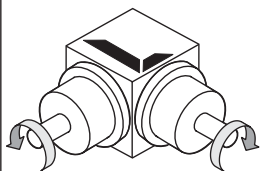

C

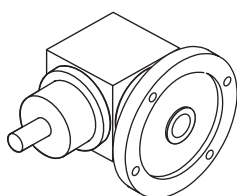

MC

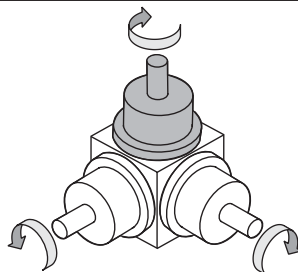

C90

Grandeur / Medida / Dimensão: 12-19-24-32-38-42-55-75, i = 1-1.5-2-3-4-5

Deux Arbres côté Sortie / Dos Ejes Salida / Dois eixos de saída

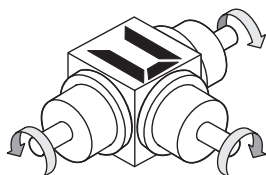

DR

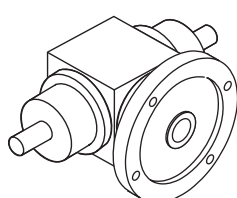

MDR

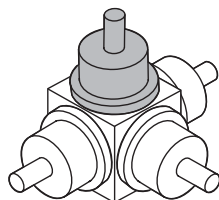

DR90

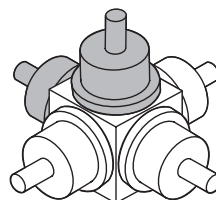

DR180

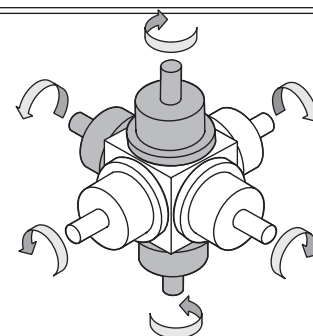

DR270



1.3 Versions

1.3 Versiones

1.3 Versões

Grandeur / Medida / Dimensão: **12-19-24-32-38-42-55-75**, **i = 1-1.5-2-3-4-5**
Deux Arbres côté Sortie / Dos Ejes Salida / Dois eixos de saída
Version multiplicateur / Versión multiplicador / Versão com multiplicador

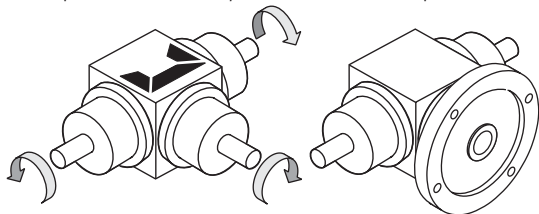

DX

MDX

Grandeur / Medida / Dimensão: **12-19-24-32-38-42-55-75** **i = 1-1.5-2-3-4-5**
Deux Arbres côté Entrée / Dos Ejes Entrada / Dois eixos em entrada

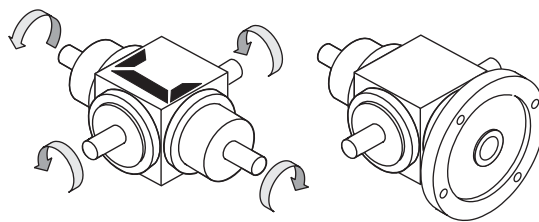

B

MB

Grandeur / Medida / Dimensão: **12-19-24-32-38-42-55-75**, **i = 1-1.5-2-3-4-5**
Deux Arbres côté Entrée / Dos Ejes Entrada / Dois eixos em entrada

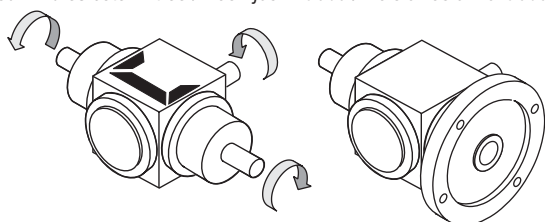

BS

MBS

Grandeur / Medida / Dimensão: **12-19-24-32-38-42-55-75**, **i = 1-1.5-2-3-4-5**
Deux Arbres côté Entrée / Dos Ejes Entrada / Dois eixos em entrada

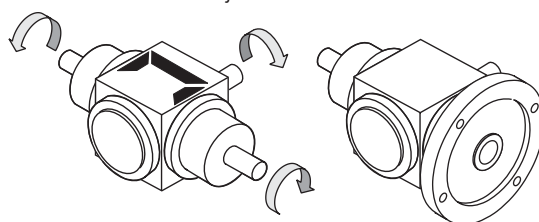

BD

MBD

Grandeur / Medida / Dimensão: **12-19-24-32-38-42-55-75**, **i = 1-1.5-2-3-4-5**

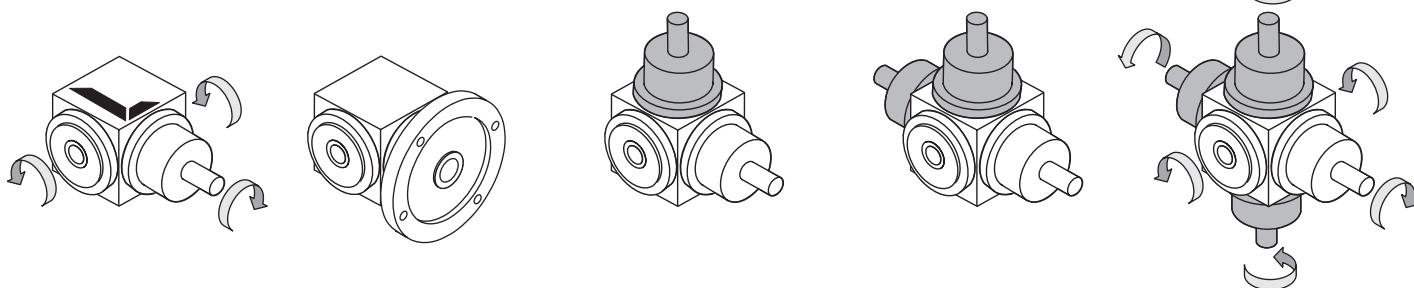

AH

MAH

AH90

AH180

AH270

Grandeur / Medida / Dimensão: **12-19-24-32-38-42-55-75**, **i = 1-1.5-2-3-4-5**
Deux Arbres côté Entrée / Dos Ejes Entrada / Dois eixos em entrada

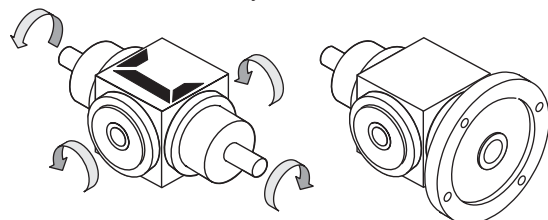

BH

MBH

1- STANDARD

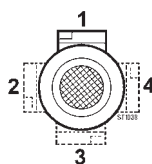

Position plaque à bornes
Posición caja de bornes
Posição terminal conector



1.4 Lubrification

1.4 Lubricación

1.4 Lubrificação

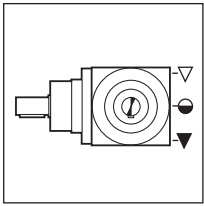

M1

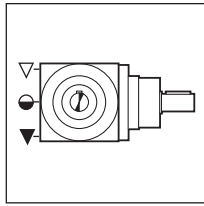

M2

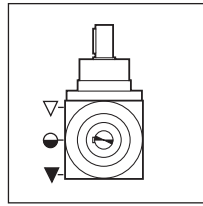

M3

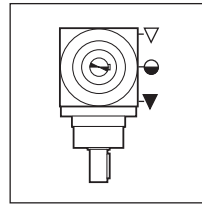

M4

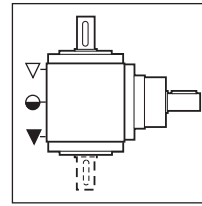

M6

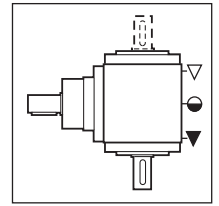

M5

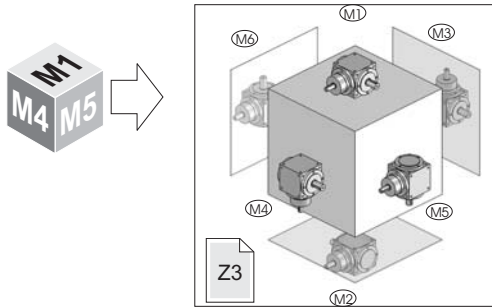

- ▽ Remplissage / Carga / Carga
- Niveau / Nivel / Nivel
- ▼ Vidange / Descarga / Descarga

ZA							
Quantité de lubrifiant - Cantidad de lubricante - Quantidade de lubrificante - [Kg]							
12	19	24	32	38	42	55	75
0.1	0.15	0.22	0.60	1.1	2.2	3.6	9.0

!
Uniquement pour ZA. Pour toute autre information, contacter notre Service Technique.

!
Sólo para ZA. Para ulteriores informaciones, contactar nuestro servicio técnico.

!
Apenas para ZA. Para Ulteriores informações Contacte o nosso serviço técnico.

Remarque : Si lors de la commande la position de montage est omise, le réducteur sera fourni avec les bouchons prédisposés pour la position M1.

Nota: Si en la fase de pedido, se omite la posición de montaje, el reductor se suministrará con los tapones predispuestos para la posición M1.

Nota: Se na fase de ordem a posição de montagem for omitida, o redutor será fornecido com os tampos preparados para a posição M1.

Toute fourniture avec des prédispositions des bouchons différents de celle indiquée dans le tableau sont à convenir.

Los eventuales suministros con predisposiciones de los tapones diferentes a la indicada en la tabla, deberán ser acordados.

Eventuais fornecimentos com preparações dos tampos diferentes da indicada na tabela, deverão ser concordadas.

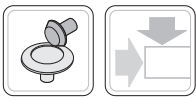

1.5 Charges radiales et axiales

Les transmissions effectuées au moyen de pignons pour chaîne, roues dentées ou poulies engendrent des forces radiales (F_r) sur les arbres des réducteurs.

Les valeurs des charges radiales et axiales générées par l'application doivent toujours être inférieures ou égales à celles admissibles indiquées dans les tableaux.

1.5 Cargas radiales et axiales

Las transmisiones efectuadas por medio de piñones para cadena, ruedas dentadas o poleas generan las fuerzas radiales (F_r) en los ejes de los reductores.

Los valores de las cargas radiales y axiales generadas por la aplicación deben ser siempre menores o iguales a aquellas admisibles, que se indican en las tablas.

1.5 Cargas radiais e axiais

As transmissões feitas através de pinhões para correia, rodas dentadas ou polias geram forças radiais (F_r) nos eixos dos redutores.

Os valores das cargas radiais e axiais gerados pela aplicação devem ser sempre menores ou iguais aos admitidos, indicados nas tabelas.

Charges radiales

Cargas radiales

Cargas radiais

Tab. 4.2

i	F_{r1} [N]							
	Z.							
	12	19	24	32	38	42	55	75
1-2-3	550	850	1400	2000	4000	6000	10000	25000
4-5	—	600	850	1400	2000	4000	6000	10000

i	F_{r2} [N]							
	Z.							
	12	19	24	32	38	42	55	75
Tous / Todos Todos	900	1500	2200	3500	7000	10000	15000	35000

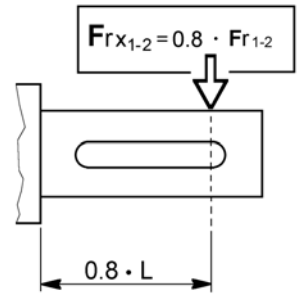
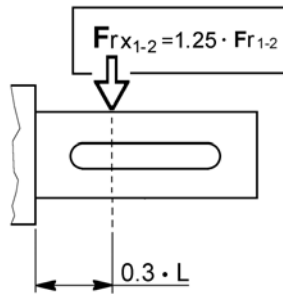
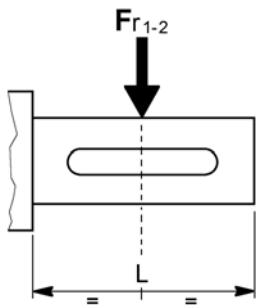

Les charges radiales indiquées dans les tableaux sont appliquées à mi-extension de l'arbre standard et elles se réfèrent aux réducteurs agissant avec facteur de service 1. Pour les charges qui n'agissent pas sur la ligne médiane de l'arbre côté sortie ou côté entrée, on a:

à 0.3 de l'extension:

$$F_{rx} = 1.25 \times F_{r1-2}$$

à 0.8 de l'extension

$$F_{rx} = 0.8 \times F_{r1-2}$$

Las cargas radiales indicadas en las tablas se entienden aplicadas en la mitad de la saliente del eje estándar y se refieren a los reductores que operan con factor de servicio 1. Para las cargas que no operan en el centro del eje lento o veloz se tiene:

a 0.3 de la saliente:

$$F_{rx} = 1.25 \times F_{r1-2}$$

a 0.8 de la saliente:

$$F_{rx} = 0.8 \times F_{r1-2}$$

As cargas radiais indicadas nas tabelas são aplicadas no centro da saliência do eixo standard e referem-se aos redutores operantes com fator de serviço 1.

Para as cargas que não agem no centro do eixo lento ou rápido tem-se:

a 0.3 da saliência:

$$F_{rx} = 1.25 \times F_{r1-2}$$

a 0.8 da saliência:

$$F_{rx} = 0.8 \times F_{r1-2}$$

Charges axiales

Cargas axiales

Cargas axiais

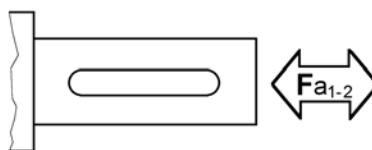



Charges axiales

Cargas axiales

Cargas axiais

Tab. 4.3

i	F _{a1} [N]							
	Z.							
	12	19	24	32	38	42	55	75
	Roulements à billes (sauf version AP) / Cojinetes de bolas (excluida versión AP) / Rolamentos de esferas (excluso versão AP)							
1-2-3	300	450	700	1100	1700	2700	5000	10000
4-5	—	400	450	700	1100	1700	2700	5000
	Roulements à rouleaux coniques (uniquement version AP) / Cojinetes de rodillos cónicos (sólo versión AP) / Rolamentos de rolos cónicos (apenas versão AP)							
1-2-3	—	650	1000	1500	2400	4000	7800	16000
4-5	—	450	650	1000	1500	2400	4000	7800

i	F _{a2} [N]							
	Z.							
	12	19	24	32	38	42	55	75
	Roulements à billes (sauf version AP) / Cojinetes de bolas (excluida versión AP) / Rolamentos de esferas (excluso versão AP)							
Tous / Todos	500	700	1300	1700	3400	4800	6800	15000
	Roulements à rouleaux coniques (uniquement version AP) / Cojinetes de rodillos cónicos (sólo versión AP) / Rolamentos de rolos cónicos (apenas versão AP)							

1.6 Couple maximal transmissible pour accouplements en série

1.6 Par máximo transmisible para acoplamientos en serie

1.6 Torque máxima transmissível para acoplamentos em série

Quand plusieurs renvois d'angle, de forme A ou bien AH, sont montés en série, il faut toujours vérifier que le couple maximal nécessaire est compatible avec le couple indiqué dans le tableau.

Cuando varios reenvíos angulares de forma A o AH, son montados en serie, es necesario siempre verificar que el par máximo necesario sea compatible con el indicado en la tabla.

Quando vários desvios angulares, de forma A ou AH, são montados em série é preciso verificar se a torque máxima necessária seja compatível com a indicada na tabela.

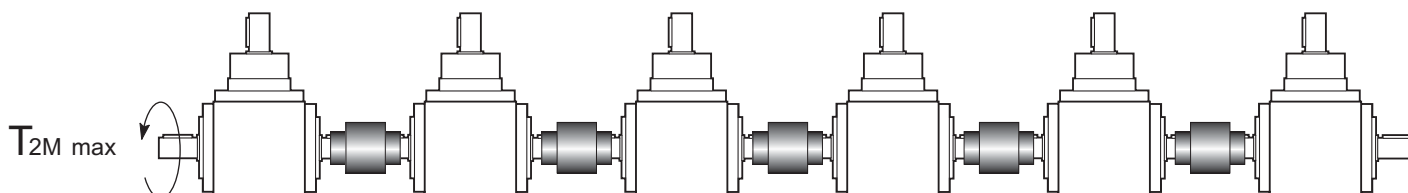

Tab. 4.4

	Z.						
	19 A 19 AH	24 A 24 AH	32 A 32 AH	38 A 38 AH	42 A 42 AH	55 A 55 AH	75 A 75 AH
T _{2M} max (Nm)	60	120	300	500	700	1600	4000

Si, au contraire, les conditions de travail sont supérieures à celles indiquées ci-dessus, il faut utiliser des renvois d'angle de forme AP avec arbre passant de dimensions supérieures, dont les couples maximums sont:

Si, en cambio, las condiciones de trabajo son superiores a aquellas antes indicadas, es necesario utilizar reenvíos angulares de forma AP con eje pasante de mayores dimensiones, cuyos pares máximos son:

Ao contrário, se as condições de funcionamento são superiores àquelas indicadas é necessário o uso de desvios angulares da forma AP com eixo passando de dimensões maiores, cujas torques máximas são:

Tab. 4.5

	Z.						
	19 AP	24 AP	32 AP	38 AP	42 AP	55 AP	75 AP
T _{2M} max (Nm)	120	300	500	700	1000	3000	6500



1.7 Performances renvois d'angle Z 1.7 Performances renvois d'angle Z 1.7 Desempenhos desvios angulares Z

Z 12 (A-AS-AD-AP-C-DR-B-BD-BS)															2.5		
ir	$n_1 = 2800 \text{ min}^{-1}$				$n_1 = 1400 \text{ min}^{-1}$				$n_1 = 900 \text{ min}^{-1}$				$n_1 = 500 \text{ min}^{-1}$				IEC
	n_2 min ⁻¹	T _{2M} Nm	P kW	RD %	n_2 min ⁻¹	T _{2M} Nm	P kW	RD %	n_2 min ⁻¹	T _{2M} Nm	P kW	RD %	n_2 min ⁻¹	T _{2M} Nm	P kW	RD %	
1	2800	13.1	4.0	95	1400	14.9	2.3	95	900	16.2	1.6	95	500	18.7	1.0	95	71 (B14) 63 (B5)
1.5	—	—	—	—	—	—	—	—	—	—	—	—	—	—	—	—	
2	1400	13.7	2.1	95	700	14.9	1.1	95	450	16.2	0.80	95	250	18.7	0.52	95	
3	933	7.5	0.77	95	467	8.9	0.46	95	300	9.7	0.32	95	167	11.1	0.20	95	
4	—	—	—	—	—	—	—	—	—	—	—	—	—	—	—	—	
5	—	—	—	—	—	—	—	—	—	—	—	—	—	—	—	—	—

Z 12 (DX) Version multiplicateur / Versión multiplicador / Versão com multiplicador															2.5	
ir	$n_1 = 1400 \text{ min}^{-1}$				$n_1 = 900 \text{ min}^{-1}$				$n_1 = 500 \text{ min}^{-1}$				IEC			
	n_2 min ⁻¹	T _{2M} Nm	P kW	RD %	n_2 min ⁻¹	T _{2M} Nm	P kW	RD %	n_2 min ⁻¹	T _{2M} Nm	P kW	RD %				
1.5	—	—	—	—	—	—	—	—	—	—	—	—	—	—	—	—
2	2800	7.5	2.3	95	1800	8.1	1.6	95	1000	9.4	1.0	95				

Z 19 (A-AS-AD-AP-C-DR-B-BD-BS-AH-BH)															6.0		
ir	$n_1 = 2800 \text{ min}^{-1}$				$n_1 = 1400 \text{ min}^{-1}$				$n_1 = 900 \text{ min}^{-1}$				$n_1 = 500 \text{ min}^{-1}$				IEC
	n_2 min ⁻¹	T _{2M} Nm	P kW	RD %	n_2 min ⁻¹	T _{2M} Nm	P kW	RD %	n_2 min ⁻¹	T _{2M} Nm	P kW	RD %	n_2 min ⁻¹	T _{2M} Nm	P kW	RD %	
1	2800	69	21	95	1400	73	11.3	95	900	75	7.4	95	500	76	4.2	95	71 (B5) 63 (B5)
1.5	1867	47	9.7	95	933	49	5.0	95	600	50	3.3	95	333	51	1.9	95	
2	1400	55	8.5	95	700	57	4.4	95	450	59	2.9	95	250	60	1.7	95	
3	933	31	3.2	95	467	32	1.6	95	300	32	1.1	95	167	33	0.61	95	
4	700	35	2.7	95	350	28	1.1	95	225	28	0.7	95	125	29	0.40	95	
5	560	28	1.7	95	280	29	0.90	95	180	29	0.6	95	100	30	0.33	95	

Z 19 (AX-DX) Version multiplicateur / Versión multiplicador / Versão com multiplicador															6.0
ir	$n_1 = 1400 \text{ min}^{-1}$				$n_1 = 900 \text{ min}^{-1}$				$n_1 = 500 \text{ min}^{-1}$				IEC		
	n_2 min ⁻¹	T _{2M} Nm	P kW	RD %	n_2 min ⁻¹	T _{2M} Nm	P kW	RD %	n_2 min ⁻¹	T _{2M} Nm	P kW	RD %			
1.5	2100	25	5.7	95	1350	25	3.7	95	750	26	2.1	95	—		
2	2800	29	8.8	95	1800	30	5.9	95	1000	30	3.3	95			

Z 24 (A-AS-AD-AP-C-DR-B-BD-BS-AH-BH)															12.0		
ir	$n_1 = 2800 \text{ min}^{-1}$				$n_1 = 1400 \text{ min}^{-1}$				$n_1 = 900 \text{ min}^{-1}$				$n_1 = 500 \text{ min}^{-1}$				IEC
	n_2 min ⁻¹	T _{2M} Nm	P kW	RD %	n_2 min ⁻¹	T _{2M} Nm	P kW	RD %	n_2 min ⁻¹	T _{2M} Nm	P kW	RD %	n_2 min ⁻¹	T _{2M} Nm	P kW	RD %	
1	2800	76	23	95	1400	82	12.7	95	900	86	8.5	95	500	90	4.9	95	90 (B5) 80 (B5) 71 (B5)
1.5	1867	78	16.0	95	933	81	8.3	95	600	83	5.5	95	333	85	3.1	95	
2	1400	69	10.7	95	700	72	5.6	95	450	74	3.6	95	250	75	2.1	95	
3	933	45	4.6	95	467	47	2.4	95	300	48	1.6	95	167	49	0.89	95	
4	700	66	5.1	95	350	69	2.6	95	225	70	1.7	95	125	71	1.0	95	
5	560	57	3.5	95	280	61	1.9	95	180	62	1.2	95	100	64	0.71	95	80 (B5) 71 (B5)

Z 24 (AX-DX) Version multiplicateur / Versión multiplicador / Versão com multiplicador															12.0
ir	$n_1 = 1400 \text{ min}^{-1}$				$n_1 = 900 \text{ min}^{-1}$				$n_1 = 500 \text{ min}^{-1}$				IEC		
	n_2 min ⁻¹	T _{2M} Nm	P kW	RD %	n_2 min ⁻¹	T _{2M} Nm	P kW	RD %	n_2 min ⁻¹	T _{2M} Nm	P kW	RD %			
1.5	2100	40	9.4	95	1350	42	6.2	95	750	43	3.5	95	—		
2	2800	36	11.2	95	1800	37	7.3	95	1000	38	4.1	95			

1.7 Performances renvois d'angle Z 1.7 Performances renvois d'angle Z 1.7 Desempenhos desvios angulares Z

Z 32 (A-AS-AD-AP-C-DR-B-BD-BS-AH-BH) 22

ir	$n_1 = 2800 \text{ min}^{-1}$				$n_1 = 1400 \text{ min}^{-1}$				$n_1 = 900 \text{ min}^{-1}$				$n_1 = 500 \text{ min}^{-1}$				IEC
	n_2 min ⁻¹	T _{2M} Nm	P kW	RD %	n_2 min ⁻¹	T _{2M} Nm	P kW	RD %	n_2 min ⁻¹	T _{2M} Nm	P kW	RD %	n_2 min ⁻¹	T _{2M} Nm	P kW	RD %	
1	2800	173	54	95	1400	187	29	95	900	195	19.3	95	500	203	11.2	95	112 (B5) 100 (B5) 90 (B5) 80 (B5)
1.5	1867	150	31	95	933	163	16.7	95	600	159	10.5	95	333	178	6.5	95	
2	1400	132	20	95	700	140	10.8	95	450	142	7.1	95	250	147	4.1	95	
3	933	94	9.6	95	467	105	5.4	95	300	107	3.5	95	167	111	2.0	95	
4	700	92	7.1	95	350	100	3.9	95	225	101	2.5	95	125	104	1.4	95	
5	560	75	4.6	95	280	80	2.5	95	180	81	1.6	95	100	84	0.93	95	90 (B5) 80 (B5)

Z 32 (AX-DX) Version multiplicateur / Versión multiplicador / Versão com multiplicador 22

ir	$n_1 = 1400 \text{ min}^{-1}$				$n_1 = 900 \text{ min}^{-1}$				$n_1 = 500 \text{ min}^{-1}$				IEC
	n_2 min ⁻¹	T _{2M} Nm	P kW	RD %	n_2 min ⁻¹	T _{2M} Nm	P kW	RD %	n_2 min ⁻¹	T _{2M} Nm	P kW	RD %	
1.5	2100	81	18.8	95	1350	80	11.9	95	750	89	7.3	95	—
2	2800	70	22	95	1800	71	14.1	95	1000	74	8.1	95	

Z 38 (A-AS-AD-AP-C-DR-B-BD-BS-AH-BH) 37

ir	$n_1 = 2800 \text{ min}^{-1}$				$n_1 = 1400 \text{ min}^{-1}$				$n_1 = 900 \text{ min}^{-1}$				$n_1 = 500 \text{ min}^{-1}$				IEC
	n_2 min ⁻¹	T _{2M} Nm	P kW	RD %	n_2 min ⁻¹	T _{2M} Nm	P kW	RD %	n_2 min ⁻¹	T _{2M} Nm	P kW	RD %	n_2 min ⁻¹	T _{2M} Nm	P kW	RD %	
1	2800	371	115	95	1400	393	61	95	900	403	40	95	500	420	23	95	132 (B5) 112 (B5) 100 (B5) 90 (B5)
1.5	1867	356	73	95	933	374	39	95	600	382	25	95	333	397	14.6	95	
2	1400	255	39	95	700	268	21	95	450	476	13.7	95	250	483	7.8	95	
3	933	192	19.8	95	467	200	10.3	95	300	205	6.8	95	167	211	3.9	95	
4	700	209	16.1	95	350	217	8.4	95	225	221	5.5	95	125	226	3.1	95	
5	560	211	13.0	95	280	219	6.8	95	180	222	4.4	95	100	228	2.5	95	112/100 (B5) 90 (B5)

Z 38 (AX-DX) Version multiplicateur / Versión multiplicador / Versão com multiplicador 37

ir	$n_1 = 1400 \text{ min}^{-1}$				$n_1 = 900 \text{ min}^{-1}$				$n_1 = 500 \text{ min}^{-1}$				IEC
	n_2 min ⁻¹	T _{2M} Nm	P kW	RD %	n_2 min ⁻¹	T _{2M} Nm	P kW	RD %	n_2 min ⁻¹	T _{2M} Nm	P kW	RD %	
1.5	2100	187	43	95	1350	191	28	95	750	198	16.4	95	—
2	2800	134	41	95	1800	138	27	95	1000	142	15.6	95	

Z 42 (A-AS-AD-AP-C-DR-B-BD-BS-AH-BH) 57

ir	$n_1 = 2800 \text{ min}^{-1}$				$n_1 = 1400 \text{ min}^{-1}$				$n_1 = 900 \text{ min}^{-1}$				$n_1 = 500 \text{ min}^{-1}$				IEC
	n_2 min ⁻¹	T _{2M} Nm	P kW	RD %	n_2 min ⁻¹	T _{2M} Nm	P kW	RD %	n_2 min ⁻¹	T _{2M} Nm	P kW	RD %	n_2 min ⁻¹	T _{2M} Nm	P kW	RD %	
1	2800	437	135	95	1400	461	71	95	900	474	47	95	500	494	27	95	160 (B5) 132 (B5) 112 (B5)
1.5	1867	339	70	95	933	421	43	95	600	434	29	95	333	447	16.4	95	
2	1400	299	46	95	700	316	24	95	450	324	16.1	95	250	334	9.2	95	
3	933	228	23	95	467	235	12.1	95	300	242	8.0	95	167	248	4.6	95	132/112 (B5)
4	700	234	18.1	95	350	243	9.4	95	225	248	6.2	95	125	254	3.5	95	
5	560	211	13.0	95	280	219	6.8	95	180	220	4.4	95	100	228	2.5	95	112 (B5)

Z 42 (AX-DX) Version multiplicateur / Versión multiplicador / Versão com multiplicador 57

ir	$n_1 = 1400 \text{ min}^{-1}$				$n_1 = 900 \text{ min}^{-1}$				$n_1 = 500 \text{ min}^{-1}$				IEC
	n_2 min ⁻¹	T _{2M} Nm	P kW	RD %	n_2 min ⁻¹	T _{2M} Nm	P kW	RD %	n_2 min ⁻¹	T _{2M} Nm	P kW	RD %	
1.5	2100	211	49	95	1350	217	32	95	750	224	18.5	95	—
2	2800	158	49	95	1800	162	32	95	1000	167	18.4	95	



1.7 Performances renvois d'angle Z 1.7 Performances renvois d'angle Z 1.7 Desempenhos desvios angulares Z

Z 55 (A-AS-AD-AP-C-DR-B-BD-BS-AH-BH)



87

ir	$n_1 = 2800 \text{ min}^{-1}$				$n_1 = 1400 \text{ min}^{-1}$				$n_1 = 900 \text{ min}^{-1}$				$n_1 = 500 \text{ min}^{-1}$				IEC
	n_2 min^{-1}	T_{2M} Nm	P kW	RD %	n_2 min^{-1}	T_{2M} Nm	P kW	RD %	n_2 min^{-1}	T_{2M} Nm	P kW	RD %	n_2 min^{-1}	T_{2M} Nm	P kW	RD %	
1	—	—	—	—	1400	992	153	95	900	1023	101	95	500	1053	58	95	160 (B5) 132 (B5) 112 (B5)
1.5	—	—	—	—	933	1057	109	95	600	1086	72	95	333	1123	41	95	
2	—	—	—	—	700	706	54	95	450	729	36	95	250	749	21	95	
3	—	—	—	—	467	481	25	95	300	497	16.4	95	167	508	9.3	95	132 (B5) 112 (B5)
4	—	—	—	—	350	621	24	95	225	636	15.8	95	125	651	9.0	95	
5	—	—	—	—	280	595	18.4	95	180	607	12.0	95	100	621	6.8	95	

Z 55 (AX-DX) Version multiplicateur / Versión multiplicador / Versão com multiplicador



87

ir	$n_1 = 1400 \text{ min}^{-1}$				$n_1 = 900 \text{ min}^{-1}$				$n_1 = 500 \text{ min}^{-1}$				IEC
	n_2 min^{-1}	T_{2M} Nm	P kW	RD %	n_2 min^{-1}	T_{2M} Nm	P kW	RD %	n_2 min^{-1}	T_{2M} Nm	P kW	RD %	
1.5	2100	529	122	95	1350	543	81	95	750	562	46	95	—
2	2800	353	109	95	1800	365	72	95	1000	375	41	95	

Z 75 (A-AS-AD-AP-C-DR-B-BD-BS-AH-BH)



255

ir	$n_1 = 2800 \text{ min}^{-1}$				$n_1 = 1400 \text{ min}^{-1}$				$n_1 = 900 \text{ min}^{-1}$				$n_1 = 500 \text{ min}^{-1}$				IEC
	n_2 min^{-1}	T_{2M} Nm	P kW	RD %	n_2 min^{-1}	T_{2M} Nm	P kW	RD %	n_2 min^{-1}	T_{2M} Nm	P kW	RD %	n_2 min^{-1}	T_{2M} Nm	P kW	RD %	
1	—	—	—	—	1400	2109	325	95	900	2202	218	95	500	2301	127	95	—
1.5	—	—	—	—	933	1754	180	95	600	1817	120	95	333	1888	69	95	
2	—	—	—	—	700	1723	133	95	450	1778	88	95	250	1841	51	95	
3	—	—	—	—	467	1772	91	95	300	1823	60	95	167	1881	35	95	
4	—	—	—	—	350	1466	57	95	225	1505	37	95	125	1547	21	95	
5	—	—	—	—	280	1278	39	95	180	1309	26	95	100	1342	14.8	95	

Z 75 (AX-DX) Version multiplicateur / Versión multiplicador / Versão com multiplicador



255

ir	$n_1 = 1400 \text{ min}^{-1}$				$n_1 = 900 \text{ min}^{-1}$				$n_1 = 500 \text{ min}^{-1}$				IEC
	n_2 min^{-1}	T_{2M} Nm	P kW	RD %	n_2 min^{-1}	T_{2M} Nm	P kW	RD %	n_2 min^{-1}	T_{2M} Nm	P kW	RD %	
1.5	2100	877	203	95	1350	909	135	95	750	944	78	95	—
2	2800	862	266	95	1800	889	176	95	1000	921	101	95	

Les poids indiqués se réfèrent au modèle de base version A, rapport ir=1.

Los pesos indicados se refieren al modelo base versión A, relación ir=1.

Os pesos indicados referem-se ao modelo base versão A, relação ir=1.

Le Tab. 4.6 indique les dimensions IEC et les combinaisons possibles arbre/bride renvoi d'angle prévu pour accouplement moteur.

En la tab. 4.6 se indican las medidas IEC y las posibles combinaciones eje/brida reenvío angular predispuesto para acoplamiento motor.

Na tb. 4.6 são indicadas as dimensões IEC e as possíveis combinações eixo/flange desvio angular predisposto para acoplamento com motor.

Tab. 4.6

Accouplements possibles avec moteurs IEC / Posibles acoplamientos con motores IEC / Possíveis acoplamentos com motores IEC							
	IEC	ir					
		1	1.5	2	3	4	5
Z 12	71	14/105 (B14)					
	63	11/140 (B5)					
Z 19	71	14/160 (B5)					
	63	11/140 (B5)					
Z 24	90	24/200 (B5)					
	80	19/200 (B5)					
	71	14/160 (B5)					
Z 32	100/112	28/250 (B5)					
	90	24/200 (B5)					
	80	19/200 (B5)					
Z 38	132	38/300 (B5)					
	100/112	28/250 (B5)					
	90	24/200 (B5)					
Z 42	160	42/350 (B5)					
	132	38/300 (B5)					
	100/112	28/250 (B5)					
Z 55	160	42/350 (B5)					
	132	38/300 (B5)					
	100/112	28/250 (B5)					

Légende:

11/140 (B5)

11/140 : combinaisons arbre/bride standard (B5) : forme de construction moteur IEC

Leyenda:

11/140 (B5)

11/140 : combinaciones eje/brida estándar (B5) : forma constructiva motor IEC

Legenda:

11/140 (B5)

11/140 : combinações eixo/flange standard (B5) : forma construtiva motor IEC

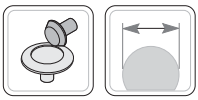

Z.A

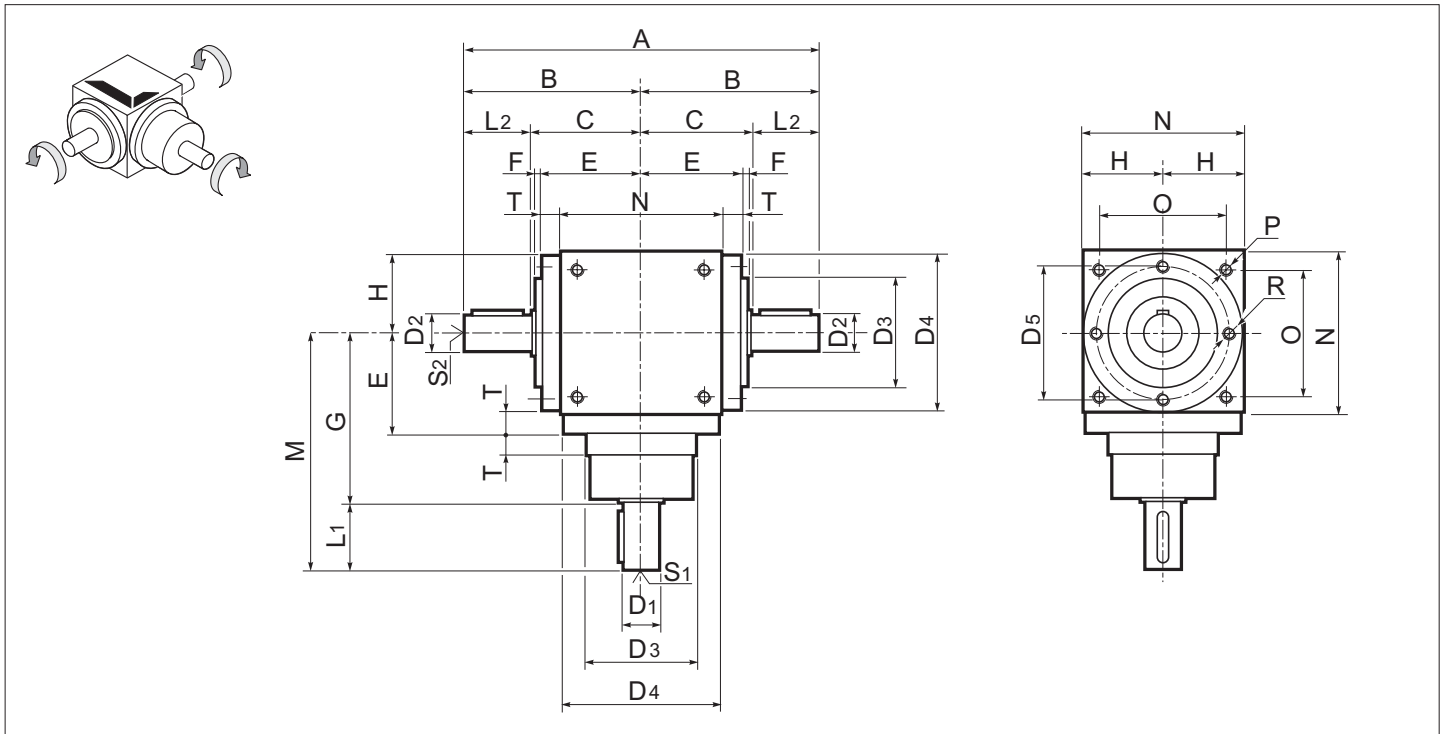

Z.MA

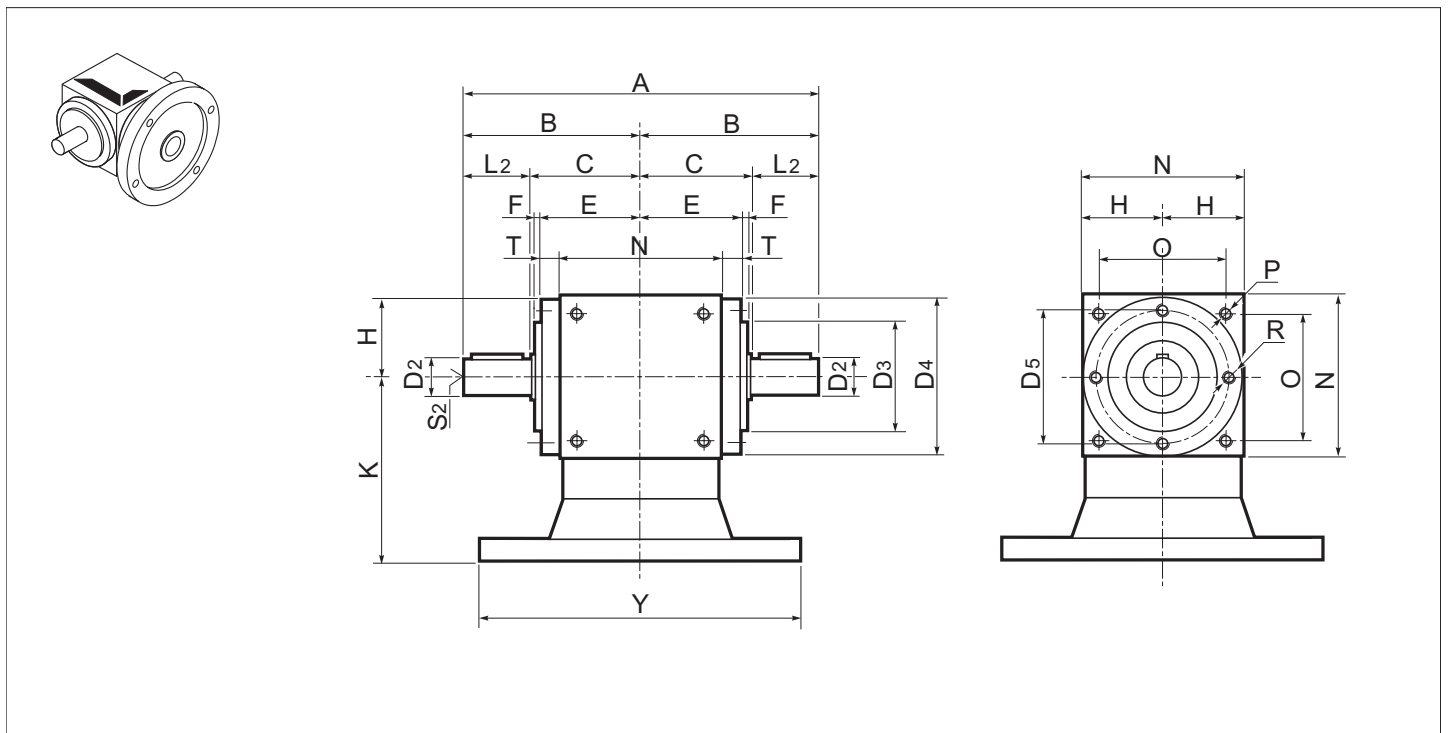



1.8 Dimensions

1.8 Dimensiones

1.8 Dimensões

Z.A	C	D3 h8	D4	D5	E	F	G	H	N	O	P	R	T
12	46	44	-	54	42	2	74	32.5	65	45	M6	M6	-
19	65	60	86	72	59	4	100	45	90	70	M6	M6	14
24	80	70	105	88	73	5	115	55	110	88	M8	M8	18
32	95	95	135	115	88	5	145	70	140	110	M10	M10	18
38	110	120	165	145	103	5	170	85	170	136	M12	M12	18
42	125	135	190	165	118	5	195	100	200	155	M12	M12	18
55	150	170	230	205	143	5	245	120	240	190	M14	M14	23
75	225	-	300	-	195	-	350	165	330	248	M16	M16	30

Z.A	ir	A	B	M	Arbre côté entrée / Eje entrada / Eixo entrada			Arbre côté sortie / Eje salida / Eixo saída		
					D1 j6	L1	S1	D2 j6	L2	S2
12	1-2-3	144	72	100	12	26	M4x8	12	26	M4x8
19	1-2-3	210	105	140	19	40	M6x12	19	40	M6x12
	4-5			130	14	30	M5x10			
24	1-2-3	260	130	165	24	50	M8x16	24	50	M8x16
	4-5			155	19	40	M6x12			
32	1-2-3	310	155	205	32	60	M10x20	32	60	M10x20
	4-5			195	24	50	M8x16			
38	1-2-3	360	180	240	38	70	M12x24	38	70	M12x24
	4-5			230	28	60	M10x20			
42	1-2-3	410	205	275	42	80	M12x24	42	80	M12x24
	4-5			255	32	60	M10x20			
55	1-2-3	520	260	355	55	110	M14x28	55	110	M14x28
	4-5			325	42	80	M12x24			
75	1-2-3	750	375	500	75	150	M16x32	75	150	M16x32
	4-5			460	55	110	M14x28			

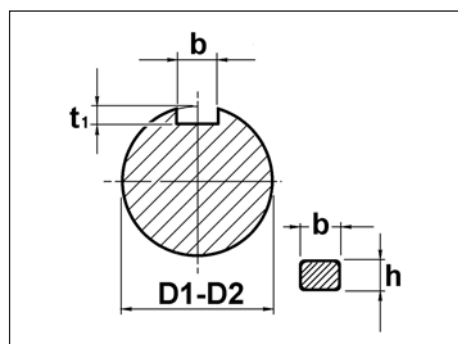

D1 - D2	b x h	t ₁
12	4 x 4	2.5
14	5 x 5	3.0
19	6 x 6	3.5
24	8 x 7	4.0
28	8 x 7	4.0
32	10 x 8	4.0
38	10 x 8	5.0
42	12 x 8	5.0
55	16 x 10	6.0
75	22 x 14	9.0

Z.MA	IEC	12		19		24		32		38		42		55	
		Y	K	Y	K	Y	K	Y	K	Y	K	Y	K	Y	K
	B5	105 (B14)	90	140	90	160	120	200	140	200	155	250	200	250	220
		140	90	160	90	200	120	250	140	250	155	300	200	300	220
										300	175	350	200	350	220

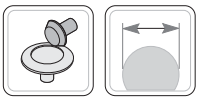

Z.AS - Z.AD

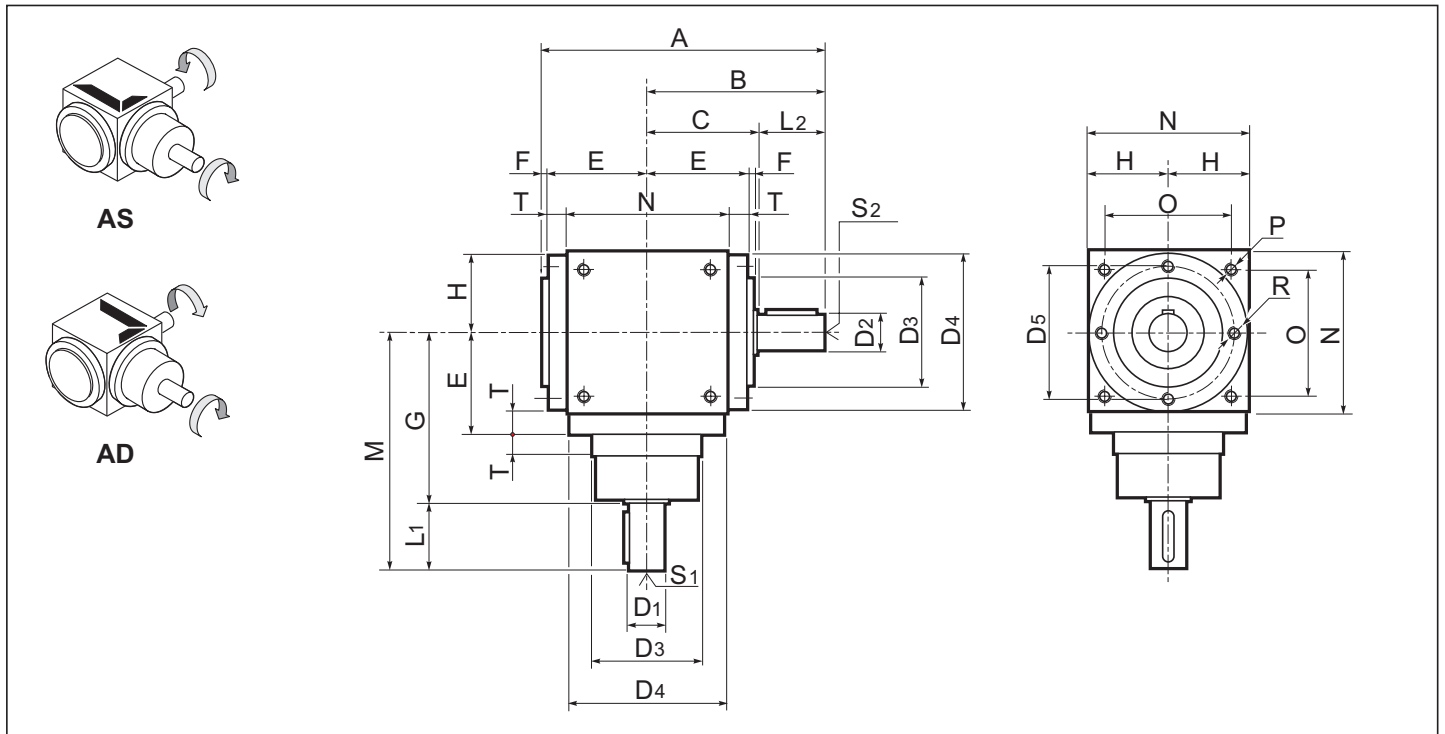

Z.MAS - Z.MAD

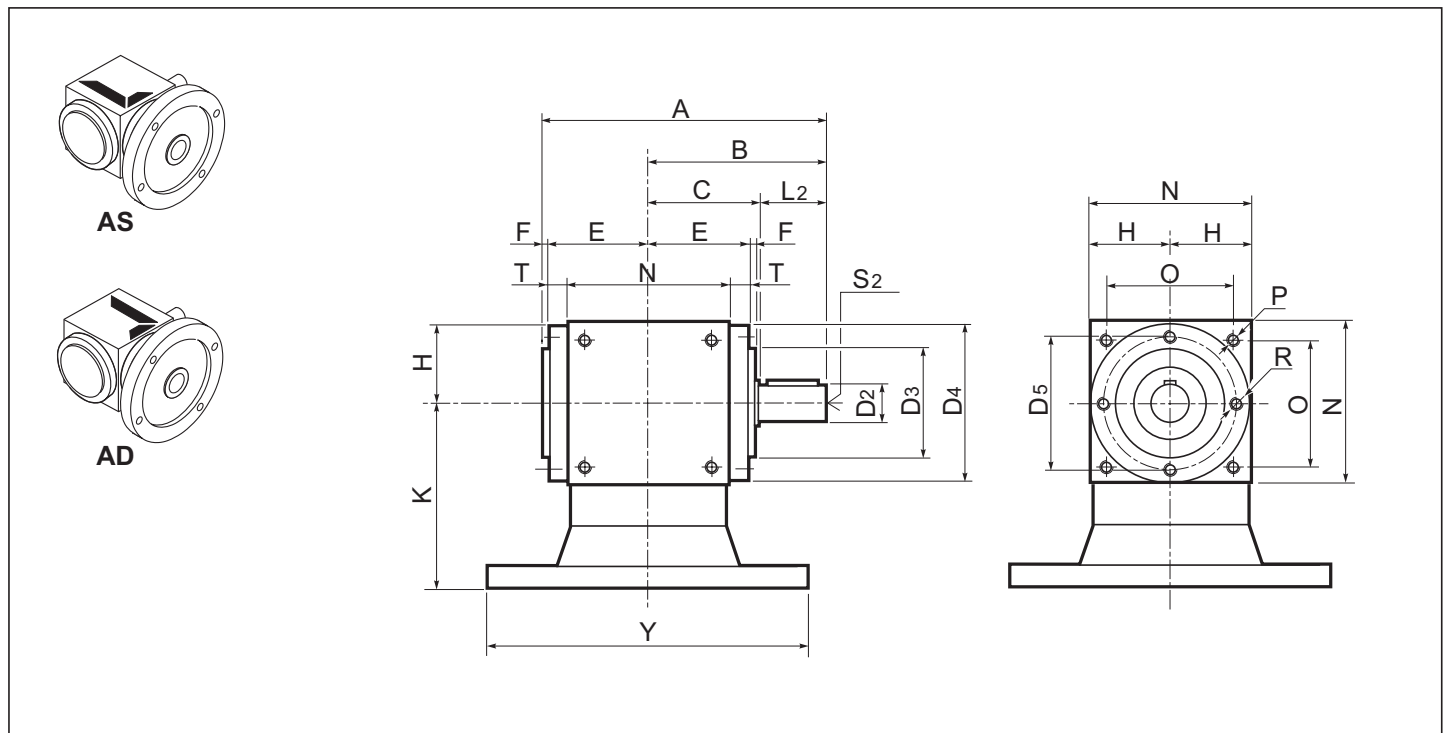

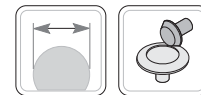

1.8 Dimensions

1.8 Dimensiones

1.8 Dimensões

Z.AS Z.AD	C	D3 h8	D4	D5	E	F	G	H	N	O	P	R	T
12	46	44	-	54	42	2	74	32.5	65	45	M6	M6	-
19	65	60	86	72	59	4	100	45	90	70	M6	M6	14
24	80	70	105	88	73	5	115	55	110	88	M8	M8	18
32	95	95	135	115	88	5	145	70	140	110	M10	M10	18
38	110	120	165	145	103	5	170	85	170	136	M12	M12	18
42	125	135	190	165	118	5	195	100	200	155	M12	M12	18
55	150	170	230	205	143	5	245	120	240	190	M14	M14	23
75	225	-	300	-	195	-	350	165	330	248	M16	M16	30

Z.AS Z.AD	ir	A	B	M	Arbre côté entrée / Eje entrada / Eixo entrada			Arbre côté sortie / Eje salida / Eixo saída		
					D1 j6	L1	S1	D2 j6	L2	S2
12	1-2-3	116	72	100	12	26	M4x8	12	26	M4x8
19	1-2-3	168	105	140	19	40	M6x12	19	40	M6x12
	4-5			130	14	30	M5x10			
24	1-2-3	208	130	165	24	50	M8x16	24	50	M8x16
	4-5			155	19	40	M6x12			
32	1-2-3	248	155	205	32	60	M10x20	32	60	M10x20
	4-5			195	24	50	M8x16			
38	1-2-3	288	180	240	38	70	M12x24	38	70	M12x24
	4-5			230	28	60	M10x20			
42	1-2-3	328	205	275	42	80	M12x24	42	80	M12x24
	4-5			255	32	60	M10x20			
55	1-2-3	408	260	355	55	110	M14x28	55	110	M14x28
	4-5			325	42	80	M12x24			
75	1-2-3	598	375	500	75	150	M16x32	75	150	M16x32
	4-5			460	55	110	M14x28			

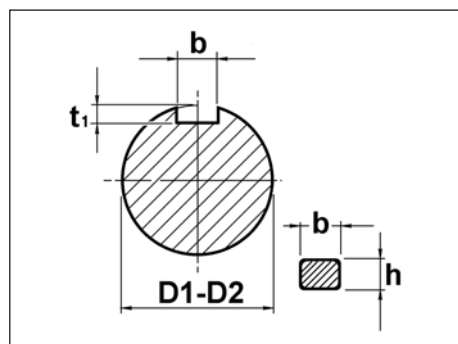

D1 - D2	b x h	t ₁
12	4 x 4	2.5
14	5 x 5	3.0
19	6 x 6	3.5
24	8 x 7	4.0
28	8 x 7	4.0
32	10 x 8	4.0
38	10 x 8	5.0
42	12 x 8	5.0
55	16 x 10	6.0
75	22 x 14	9.0

Z.MAS Z.MAD	IEC	12		19		24		32		38		42		55	
		Y	K	Y	K	Y	K	Y	K	Y	K	Y	K	Y	K
	B5	105 (B14)	90	140	90	160	120	200	140	200	155	250	200	250	220
		140	90	160	90	200	120	250	140	250	155	300	200	300	220
										300	175	350	200	350	220

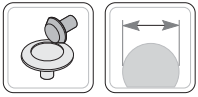

Z.AX

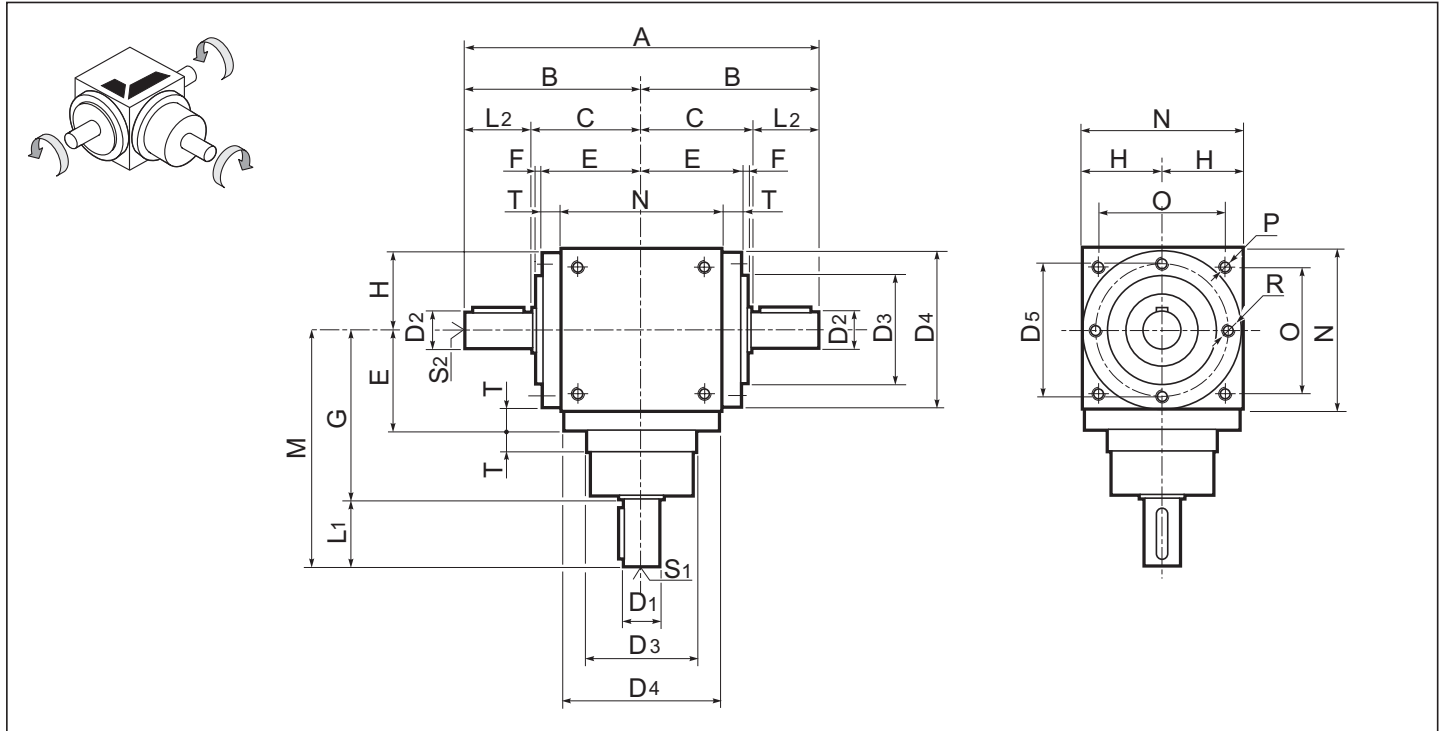



1.8 Dimensions

1.8 Dimensiones

1.8 Dimensões

Z.AX	C	D3 h8	D4	D5	E	F	G	H	N	O	P	R	T
12	—	—	—	—	—	—	—	—	—	—	—	—	—
19	65	60	86	72	59	4	100	45	90	70	M6	M6	14
24	80	70	105	88	73	5	115	55	110	88	M8	M8	18
32	95	95	135	115	88	5	145	70	140	110	M10	M10	18
38	110	120	165	145	103	5	170	85	170	136	M12	M12	18
42	125	135	190	165	118	5	195	100	200	155	M12	M12	18
55	150	170	230	205	143	5	245	120	240	190	M14	M14	23
75	225	—	300	—	195	—	350	165	330	248	M16	M16	30

Z.AX	ir	A	B	M	Arbre côté entrée / Eje entrada / Eixo entrada			Arbre côté sortie / Eje salida / Eixo saída				
					D1 j6	L1	S1	D2 j6	L2	S2		
12	—	—	—	—	—	—	—	—	—	—	—	—
19	1.5	190	95	140	19	40	M6x12	14	30	M5x10		
	2											
24	1.5	240	120	165	24	50	M8x16	19	40	M6x12		
	2											
32	1.5	290	145	205	32	60	M10x20	24	50	M8x16		
	2											
38	1.5	340	170	240	38	70	M12x24	28	60	M10x20		
	2											
42	1.5	390	195	275	42	80	M12x24	38	70	M10x20		
	2											
55	1.5	460	230	355	55	110	M14x28	42	80	M12x24		
	2											
75	1.5	670	335	500	75	150	M16x32	55	110	M14x28		
	2											

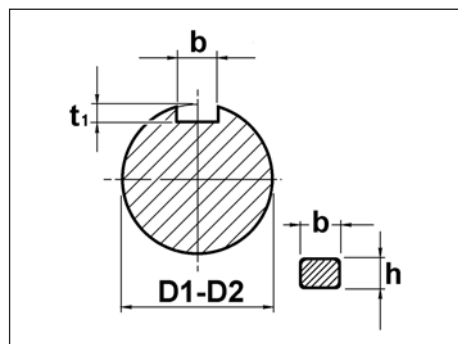

D1 - D2	b x h	t ₁	
12	4 x 4	2.5	
14	5 x 5	3.0	+0.1 0
19	6 x 6	3.5	
24	8 x 7	4.0	
28	8 x 7	4.0	
32	10 x 8	4.0	
38	10 x 8	5.0	+0.2 0
42	12 x 8	5.0	
55	16 x 10	6.0	
75	22 x 14	9.0	



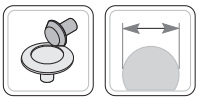

Z.AP

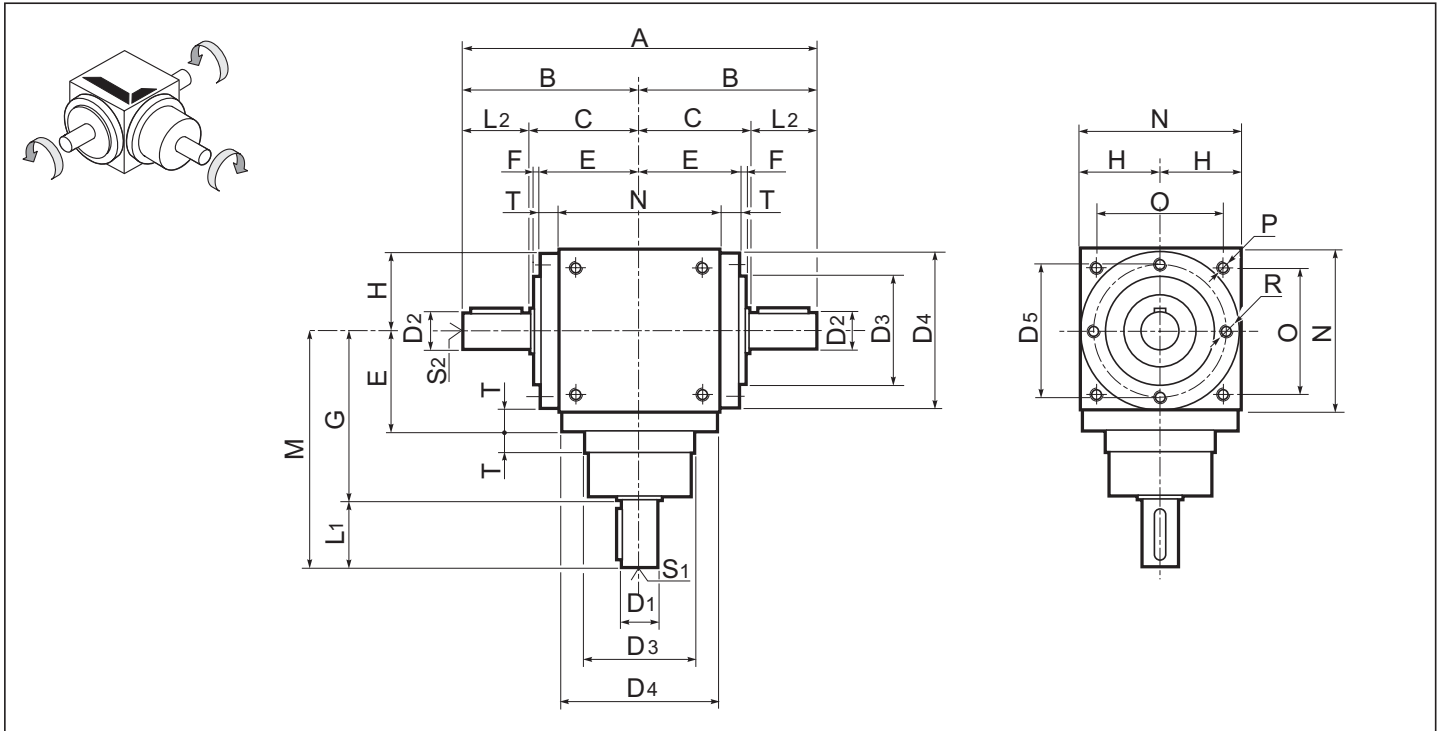



1.8 Dimensions

1.8 Dimensiones

1.8 Dimensões

Z.AP	C	D3 h8	D4	D5	E	F	G	H	N	O	P	R	T
12	—	—	—	—	—	—	—	—	—	—	—	—	—
19	65	60	86	72	59	4	100	45	90	70	M6	M6	14
24	80	70	105	88	73	5	115	55	110	88	M8	M8	18
32	95	95	135	115	88	5	145	70	140	110	M10	M10	18
38	110	120	165	145	103	5	170	85	170	136	M12	M12	18
42	125	135	190	165	118	5	195	100	200	155	M12	M12	18
55	150	170	230	205	143	5	245	120	240	190	M14	M14	23
75	225	—	300	—	195	—	350	165	330	248	M16	M16	30

Z.AP	ir	A	B	M	Arbre côté entrée / Eje entrada / Eixo entrada			Arbre côté sortie / Eje salida / Eixo saída				
					D1 j6	L1	S1	D2 j6	L2	S2		
12	1-2-3	—	—	—	—	—	—	—	—	—	—	—
19	1-2-3	230	115	140	19	40	M6x12	24	50	M8x16		
	4-5				130	30	M5x10					
24	1-2-3	280	140	165	24	50	M8x16	32	60	M10x20		
	4-5				155	40	M6x12					
32	1-2-3	330	165	205	32	60	M10x20	38	70	M12x24		
	4-5				195	24	M8x16					
38	1-2-3	380	190	240	38	70	M12x24	42	80	M12x24		
	4-5				230	28	M10x20					
42	1-2-3	430	215	275	42	80	M12x24	48	90	M14x28		
	4-5				255	32	M10x20					
55	1-2-3	520	260	355	55	110	M14x28	70	110	M14x28		
	4-5				325	42	M12x24					
75	1-2-3	750	375	500	75	150	M16x32	90	150	M16x32		
	4-5				460	55	M14x28					

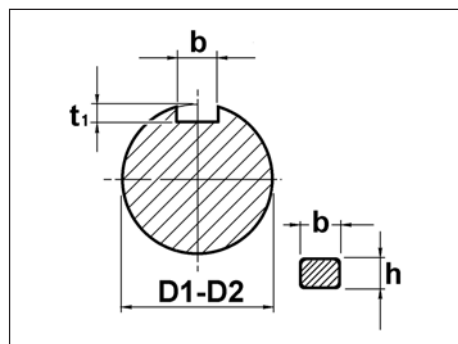

D1 - D2	b x h	t ₁
12	4 x 4	2.5
14	5 x 5	3.0
19	6 x 6	3.5
24	8 x 7	4.0
28	8 x 7	4.0
32	10 x 8	4.0
38	10 x 8	5.0
42	12 x 8	5.0
48	14 x 9	5.5
55	16 x 10	6.0
70	20 x 12	7.5
75	22 x 14	9.0
90	25 x 14	9.0

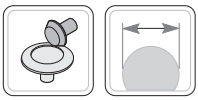

Z.C

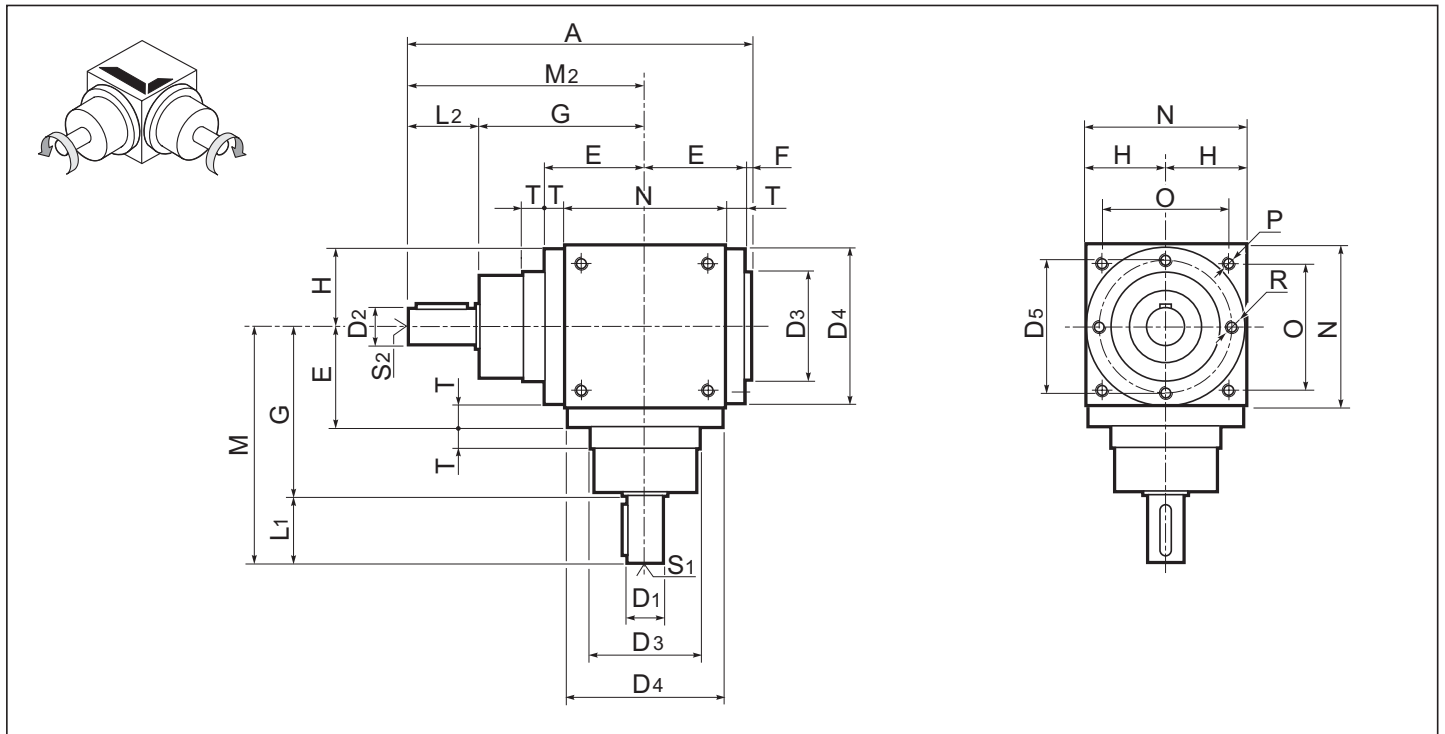

Z.MC

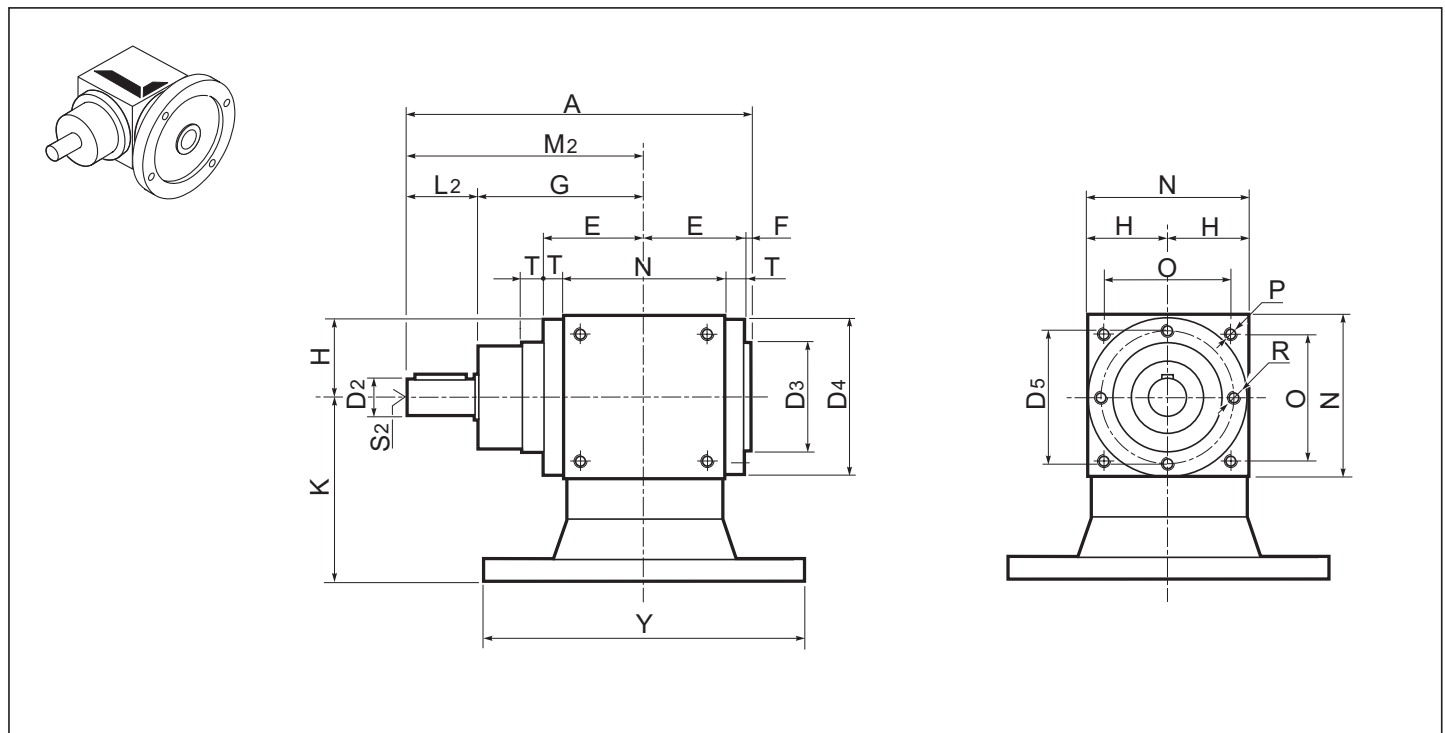



1.8 Dimensions

1.8 Dimensiones

1.8 Dimensões

Z.C	D3 h8	D4	D5	E	F	G	H	N	O	P	R	T
12	44	-	54	42	2	74	32.5	65	45	M6	M6	-
19	60	86	72	59	4	100	45	90	70	M6	M6	14
24	70	105	88	73	5	115	55	110	88	M8	M8	18
32	95	135	115	88	5	145	70	140	110	M10	M10	18
38	120	165	145	103	5	170	85	170	136	M12	M12	18
42	135	190	165	118	5	195	100	200	155	M12	M12	18
55	170	230	205	143	5	245	120	240	190	M14	M14	23
75	-	300	-	195	-	350	165	330	248	M16	M16	30

Z.C	ir	A	M	M2	Arbre côté entrée / Eje entrada / Eixo entrada			Arbre côté sortie / Eje salida / Eixo saída		
					D1 j6	L1	S1	D2 j6	L2	S2
12	1-2-3	144	100	100	12	26	M4x8	12	26	M4x8
19	1-2-3	203	140	140	19	40	M6x12	19	40	M6x12
	4-5		130		14	30	M5x10			
24	1-2-3	243	165	165	24	50	M8x16	24	50	M8x16
	4-5		155		19	40	M6x12			
32	1-2-3	298	205	205	32	60	M10x20	32	60	M10x20
	4-5		195		24	50	M8x16			
38	1-2-3	348	240	240	38	70	M12x24	38	70	M12x24
	4-5		230		28	60	M10x20			
42	1-2-3	398	275	275	42	80	M12x24	42	80	M12x24
	4-5		255		32	60	M10x20			
55	1-2-3	503	355	355	55	110	M14x28	55	110	M14x28
	4-5		325		42	80	M12x24			
75	1-2-3	723	500	500	75	150	M16x32	75	150	M16x32
	4-5		460		55	110	M14x28			

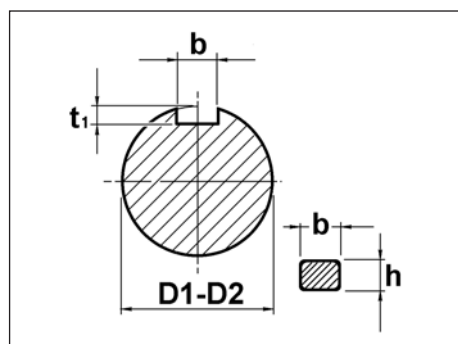

D1 - D2	b x h	t ₁
12	4 x 4	2.5
14	5 x 5	3.0
19	6 x 6	3.5
24	8 x 7	4.0
28	8 x 7	4.0
32	10 x 8	4.0
38	10 x 8	5.0
42	12 x 8	5.0
55	16 x 10	6.0
75	22 x 14	9.0

Z.MC	IEC	12		19		24		32		38		42		55	
		Y	K	Y	K	Y	K	Y	K	Y	K	Y	K	Y	K
	B5	105 (B14)	90	140	90	160	120	200	140	200	155	250	200	250	220
		140	90	160	90	200	120	250	140	250	155	300	200	300	220
										300	175	350	200	350	220

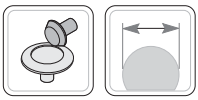

Z.DR

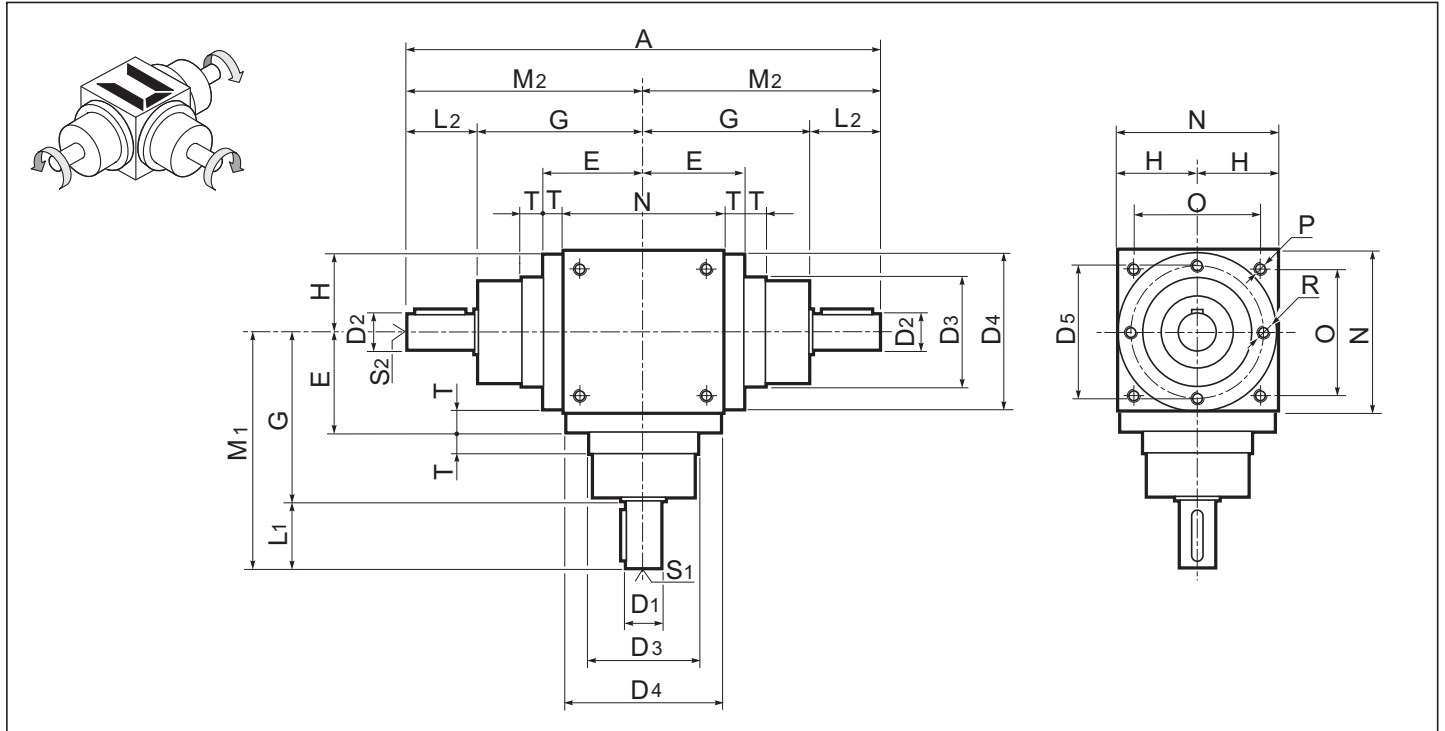

Z.MDR

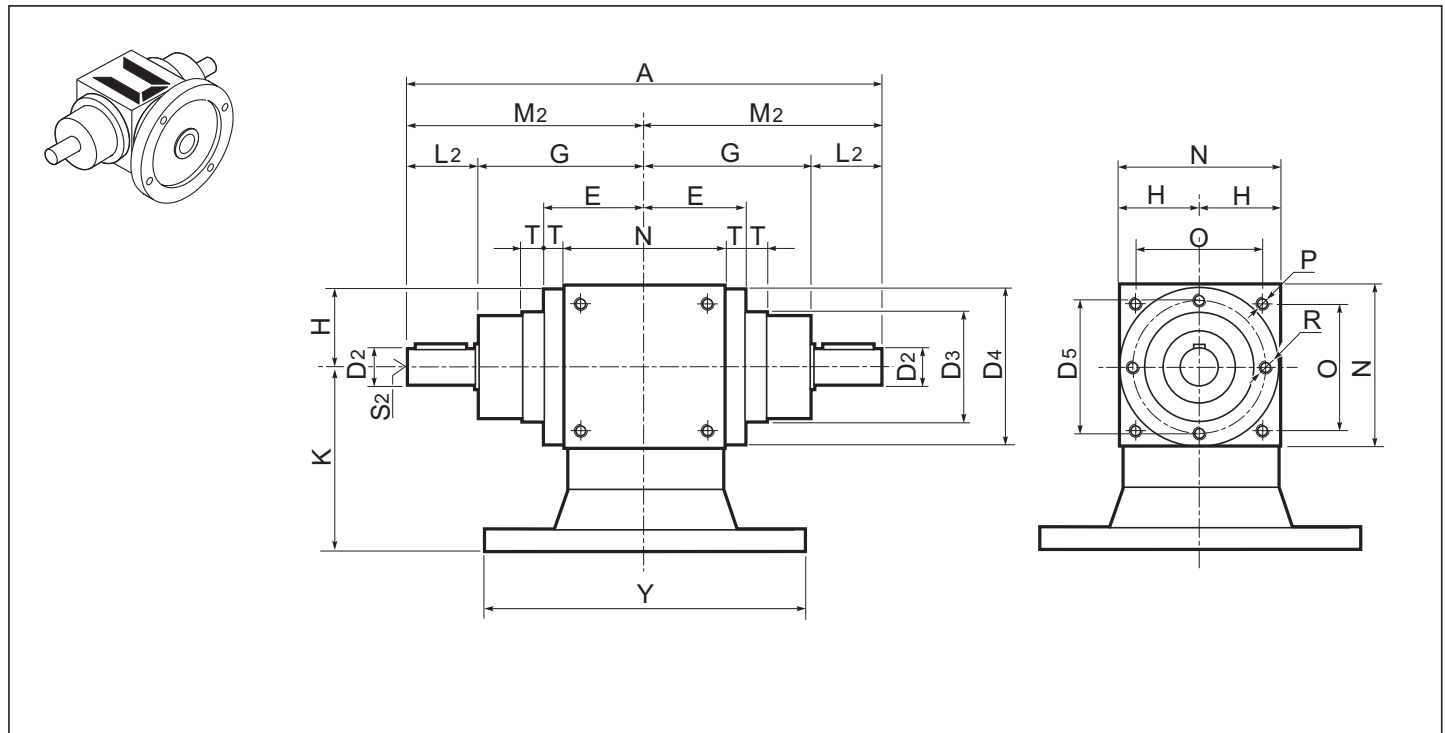



1.8 Dimensions

1.8 Dimensiones

1.8 Dimensões

Z.DR	D3 h8	D4	D5	E	F	G	H	N	O	P	R	T
12	44	—	54	42	2	74	32.5	65	45	M6	M6	—
19	60	86	72	59	4	100	45	90	70	M6	M6	14
24	70	105	88	73	5	115	55	110	88	M8	M8	18
32	95	135	115	88	5	145	70	140	110	M10	M10	18
38	120	165	145	103	5	170	85	170	136	M12	M12	18
42	135	190	165	118	5	195	100	200	155	M12	M12	18
55	170	230	205	143	5	245	120	240	190	M14	M14	23
75	—	300	—	195	—	350	165	330	248	M16	M16	30

Z.DR	ir	A	M1	M2	Arbre côté entrée / Eje entrada / Eixo entrada			Arbre côté sortie / Eje salida / Eixo saída		
					D1 j6	L1	S1	D2 j6	L2	S2
12	1-2-3	200	100	100	12	26	M4x8	12	26	M4x8
19	1-2-3	280	140	140	19	40	M6x12	19	40	M6x12
	4-5		130		14	30	M5x10			
24	1-2-3	330	165	165	24	50	M8x16	24	50	M8x16
	4-5		155		19	40	M6x12			
32	1-2-3	410	205	205	32	60	M10x20	32	60	M10x20
	4-5		195		24	50	M8x16			
38	1-2-3	480	240	240	38	70	M12x24	38	70	M12x24
	4-5		230		28	60	M10x20			
42	1-2-3	550	275	275	42	80	M12x24	42	80	M12x24
	4-5		255		32	60	M10x20			
55	1-2-3	710	355	355	55	110	M14x28	55	110	M14x28
	4-5		325		42	80	M12x24			
75	1-2-3	1000	500	500	75	150	M16x32	75	150	M16x32
	4-5		460		55	110	M14x28			

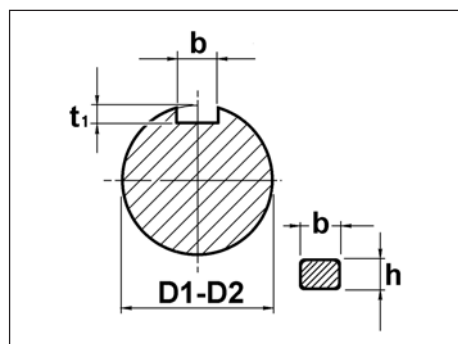

D1 - D2	b x h	t ₁
12	4 x 4	2.5
14	5 x 5	3.0
19	6 x 6	3.5
24	8 x 7	4.0
28	8 x 7	4.0
32	10 x 8	4.0
38	10 x 8	5.0
42	12 x 8	5.0
55	16 x 10	6.0
75	22 x 14	9.0

Z.MDR	IEC	12		19		24		32		38		42		55	
		Y	K	Y	K	Y	K	Y	K	Y	K	Y	K	Y	K
	B5	105 (B14)	90	140	90	160	120	200	140	200	155	250	200	250	220
		140	90	160	90	200	120	250	140	250	155	300	200	300	220
										300	175	350	200	350	220

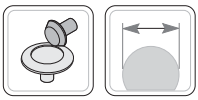

Z.DX

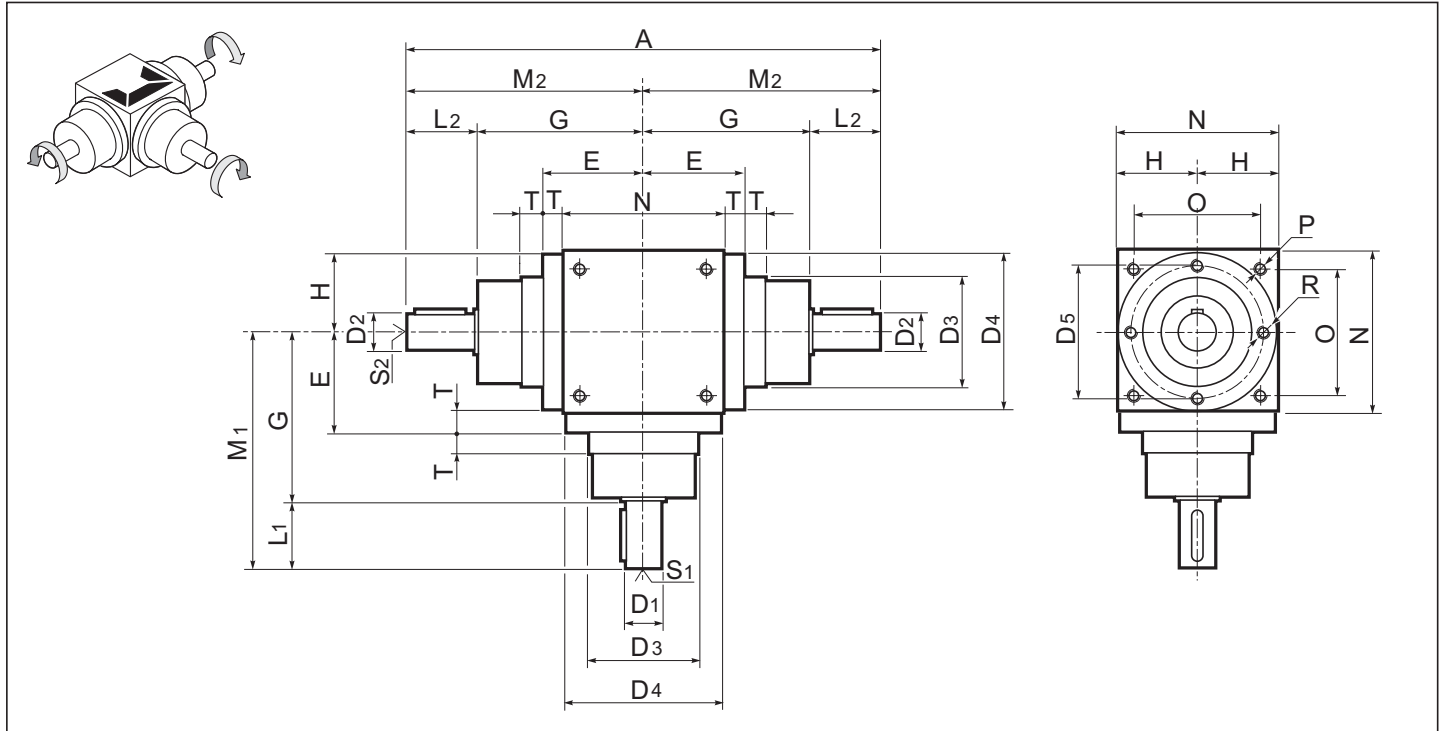

Z.MDX

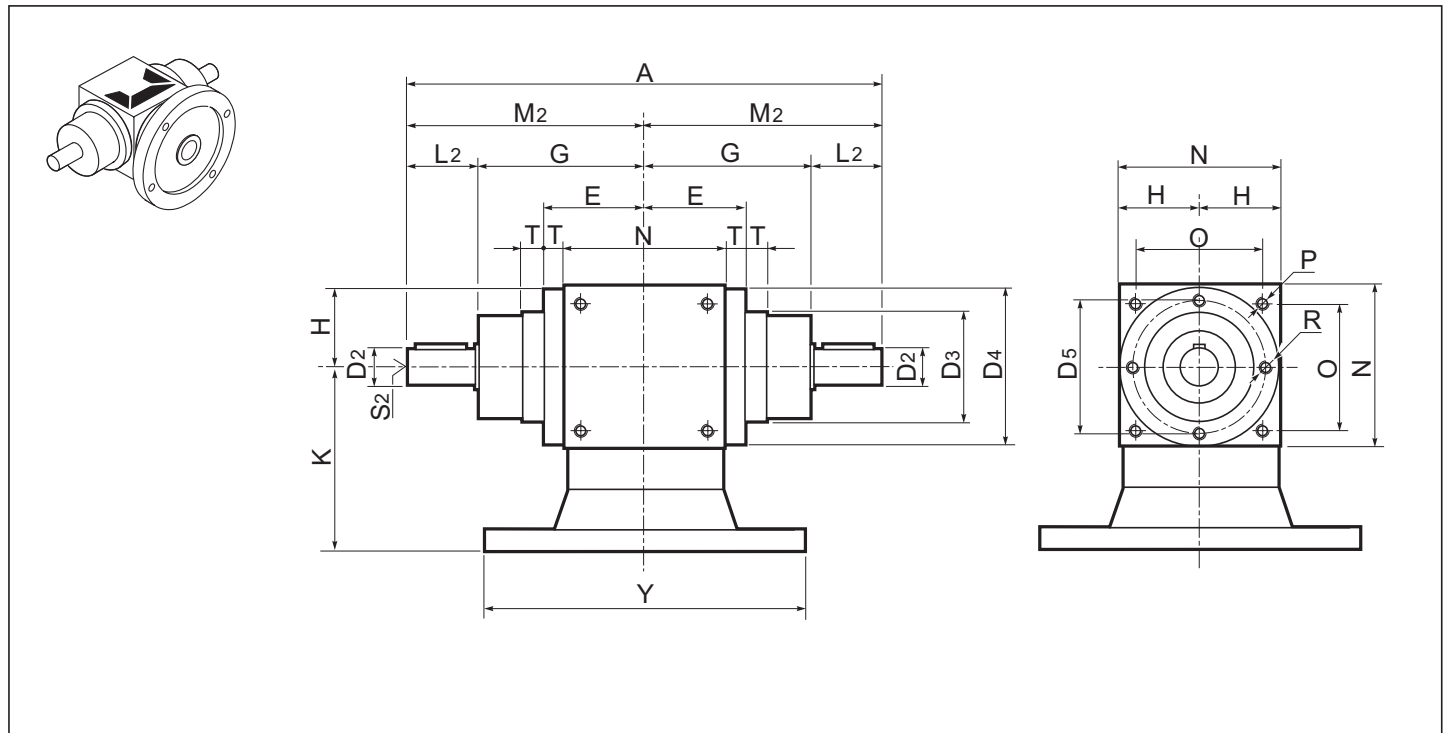



1.8 Dimensions

1.8 Dimensiones

1.8 Dimensões

Z.DX	D3 h8	D4	D5	E	G	H	N	O	P	R	T
12	44	-	54	42	74	32.5	65	45	M6	M6	-
19	60	86	72	59	100	45	90	70	M6	M6	14
24	70	105	88	73	115	55	110	88	M8	M8	18
32	95	135	115	88	145	70	140	110	M10	M10	18
38	120	165	145	103	170	85	170	136	M12	M12	18
42	135	190	165	118	195	100	200	155	M12	M12	18
55	170	230	205	143	245	120	240	190	M14	M14	23
75	-	300	-	195	350	165	330	248	M16	M16	30

Z.DX	ir	A	M1	M2	Arbre côté entrée / Eje entrada / Eixo entrada			Arbre côté sortie / Eje salida / Eixo saída		
					D1 j6	L1	S1	D2 j6	L2	S2
12	1-2-3	200	100	100	12	26	M4x8	12	26	M4x8
19	1-2-3	280	140	140	19	40	M6x12	19	40	M6x12
	4-5	260	130		14	30	M5x10			
24	1-2-3	330	165	165	24	50	M8x16	24	50	M8x16
	4-5	310	155		19	40	M6x12			
32	1-2-3	410	205	205	32	60	M10x20	32	60	M10x20
	4-5	390	195		24	50	M8x16			
38	1-2-3	480	240	240	38	70	M12x24	38	70	M12x24
	4-5	460	230		28	60	M10x20			
42	1-2-3	550	275	275	42	80	M12x24	42	80	M12x24
	4-5	510	255		32	60	M10x20			
55	1-2-3	710	355	355	55	110	M14x28	55	110	M14x28
	4-5	650	325		42	80	M12x24			
75	1-2-3	1000	500	500	75	150	M16x32	75	150	M16x32
	4-5	920	460		55	110	M14x28			

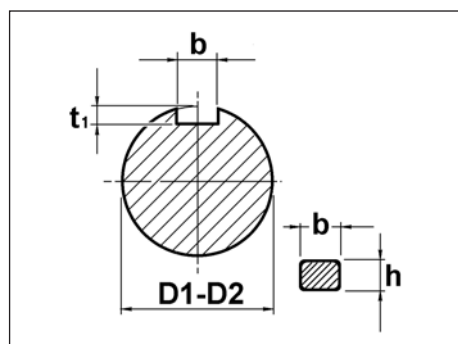

D1 - D2	b x h	t ₁
12	4 x 4	2.5
14	5 x 5	3.0
19	6 x 6	3.5
24	8 x 7	4.0
28	8 x 7	4.0
32	10 x 8	4.0
38	10 x 8	5.0
42	12 x 8	5.0
55	16 x 10	6.0
75	22 x 14	9.0

Z.MDX	IEC	12		19		24		32		38		42		55	
		Y	K	Y	K	Y	K	Y	K	Y	K	Y	K	Y	K
	B5	105 (B14)	90	140	90	160	120	200	140	200	155	250	200	250	220
		140	90	160	90	200	120	250	140	250	155	300	200	300	220
										300	175	350	200	350	220

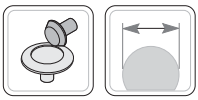

1.8 Dimensions

1.8 Dimensiones

1.8 Dimensões

Z.B

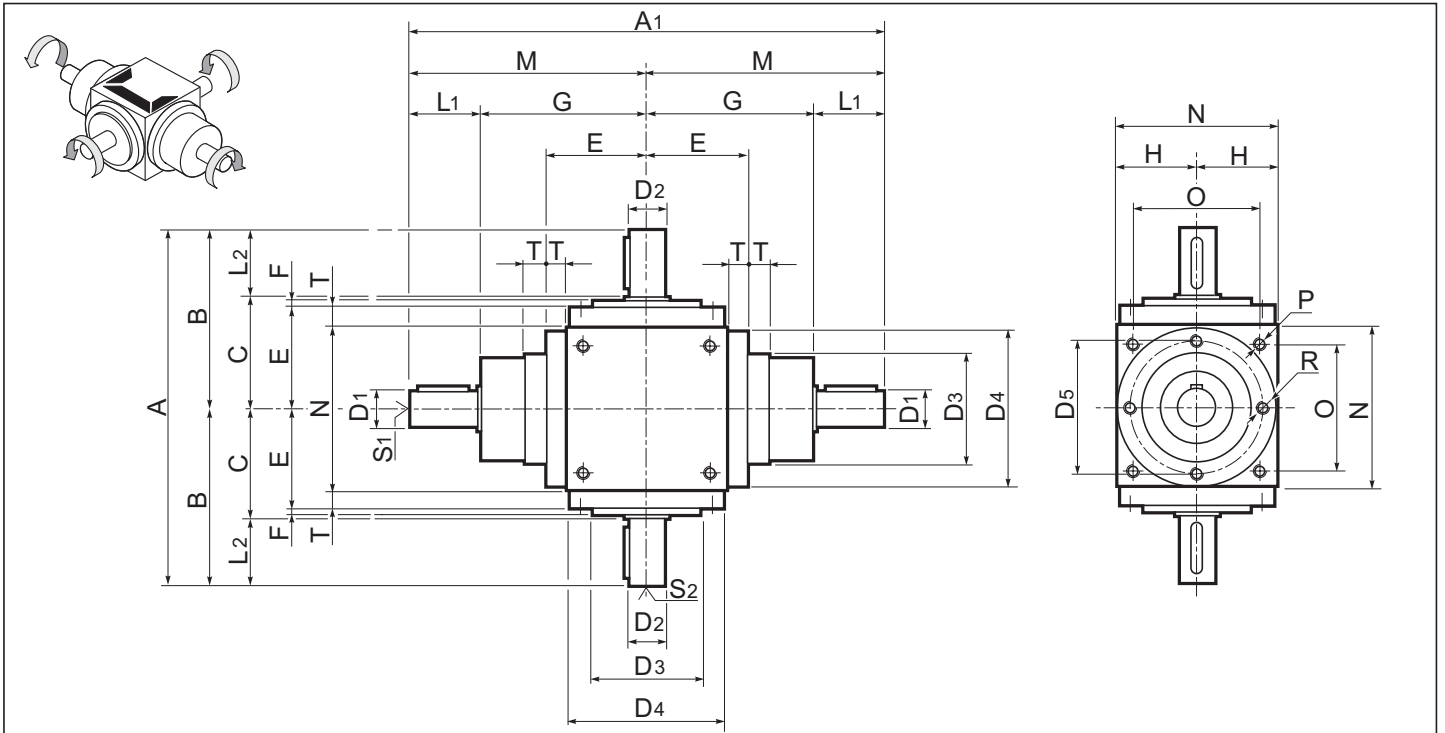

Z.MB

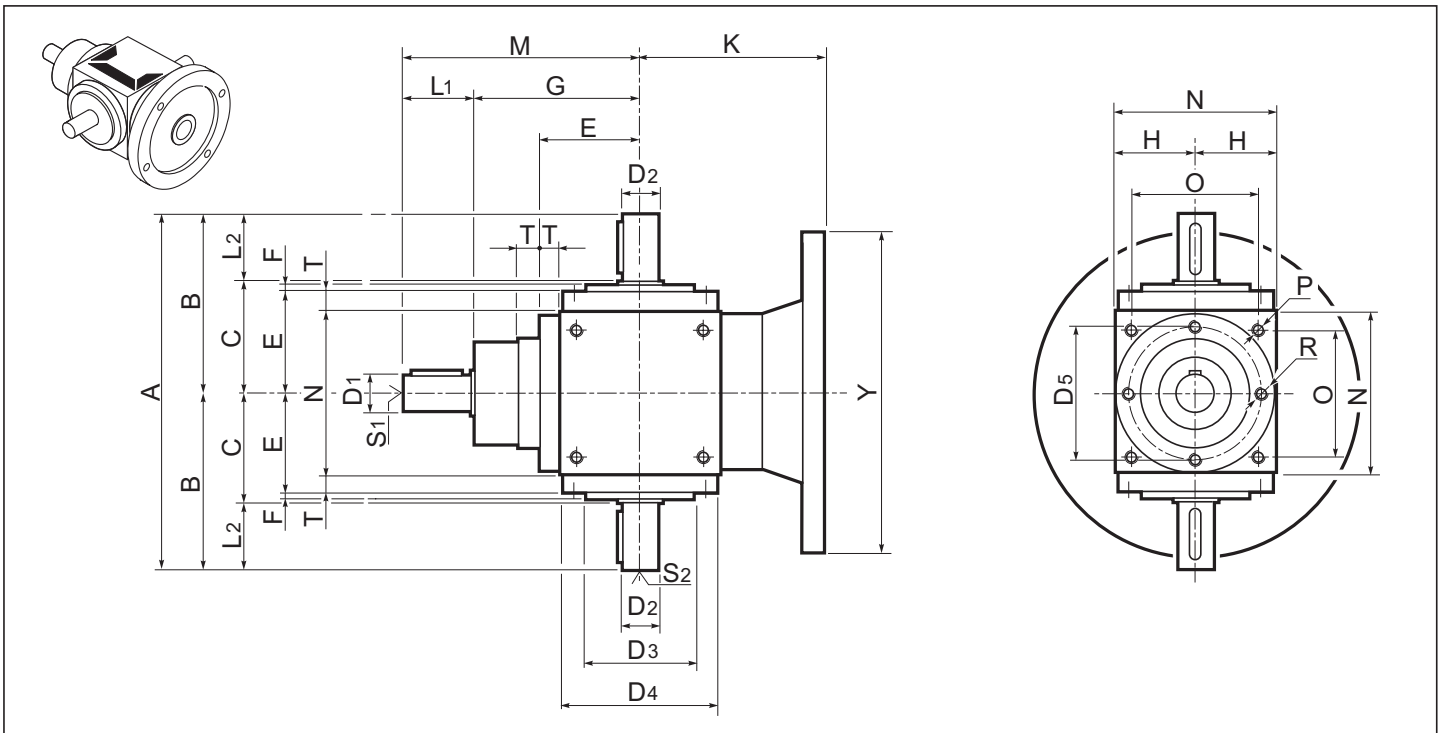



1.8 Dimensions

1.8 Dimensiones

1.8 Dimensões

Z.B	C	D3 h8	D4	D5	E	F	G	H	N	O	P	R	T
12	46	44	—	54	42	2	74	32.5	65	45	M6	M6	—
19	65	60	86	72	59	4	100	45	90	70	M6	M6	14
24	80	70	105	88	73	5	115	55	110	88	M8	M8	18
32	95	95	135	115	88	5	145	70	140	110	M10	M10	18
38	110	120	165	145	103	5	170	85	170	136	M12	M12	18
42	125	135	190	165	118	5	195	100	200	155	M12	M12	18
55	150	170	230	205	143	5	245	120	240	190	M14	M14	23
75	225	—	300	—	195	—	350	165	330	248	M16	M16	30

Z.B	ir	A1	A2	B	M	Arbre côté entrée / Input shaft / Antriebswelle			Arbre côté sortie / Eje salida / Eixo saída		
						D1 j6	L1	S1	D2 j6	L2	S2
12	1-2-3	200	144	72	100	12	26	M4x8	12	26	M4x8
19	1-2-3	280	210	105	140	19	40	M6x12	19	40	M6x12
	4-5	260			130	14	30	M5x10			
24	1-2-3	330	260	130	165	24	50	M8x16	24	50	M8x16
	4-5	310			155	19	40	M6x12			
32	1-2-3	410	310	155	205	32	60	M10x20	32	60	M10x20
	4-5	390			195	24	50	M8x16			
38	1-2-3	480	360	180	240	38	70	M12x24	38	70	M12x24
	4-5	460			230	28	60	M10x20			
42	1-2-3	550	410	205	275	42	80	M12x24	42	80	M12x24
	4-5	510			255	32	60	M10x20			
55	1-2-3	710	520	260	355	55	110	M14x28	55	110	M14x28
	4-5	650			325	42	80	M12x24			
75	1-2-3	1000	750	375	500	75	150	M16x32	75	150	M16x32
	4-5	920			460	55	110	M14x28			

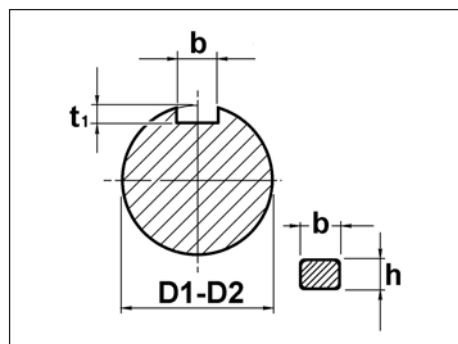

D1 - D2	b x h	t ₁
12	4 x 4	2.5
14	5 x 5	3.0
19	6 x 6	3.5
24	8 x 7	4.0
28	8 x 7	4.0
32	10 x 8	4.0
38	10 x 8	5.0
42	12 x 8	5.0
55	16 x 10	6.0
75	22 x 14	9.0

Z.MB	IEC	12		19		24		32		38		42		55	
		Y	K	Y	K	Y	K	Y	K	Y	K	Y	K	Y	K
	B5	105 (B14)	90	140	90	160	120	200	140	200	155	250	200	250	220
		140	90	160	90	200	120	250	140	250	155	300	200	300	220
										300	175	350	200	350	220

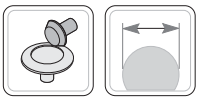

Z.BS - Z.BD

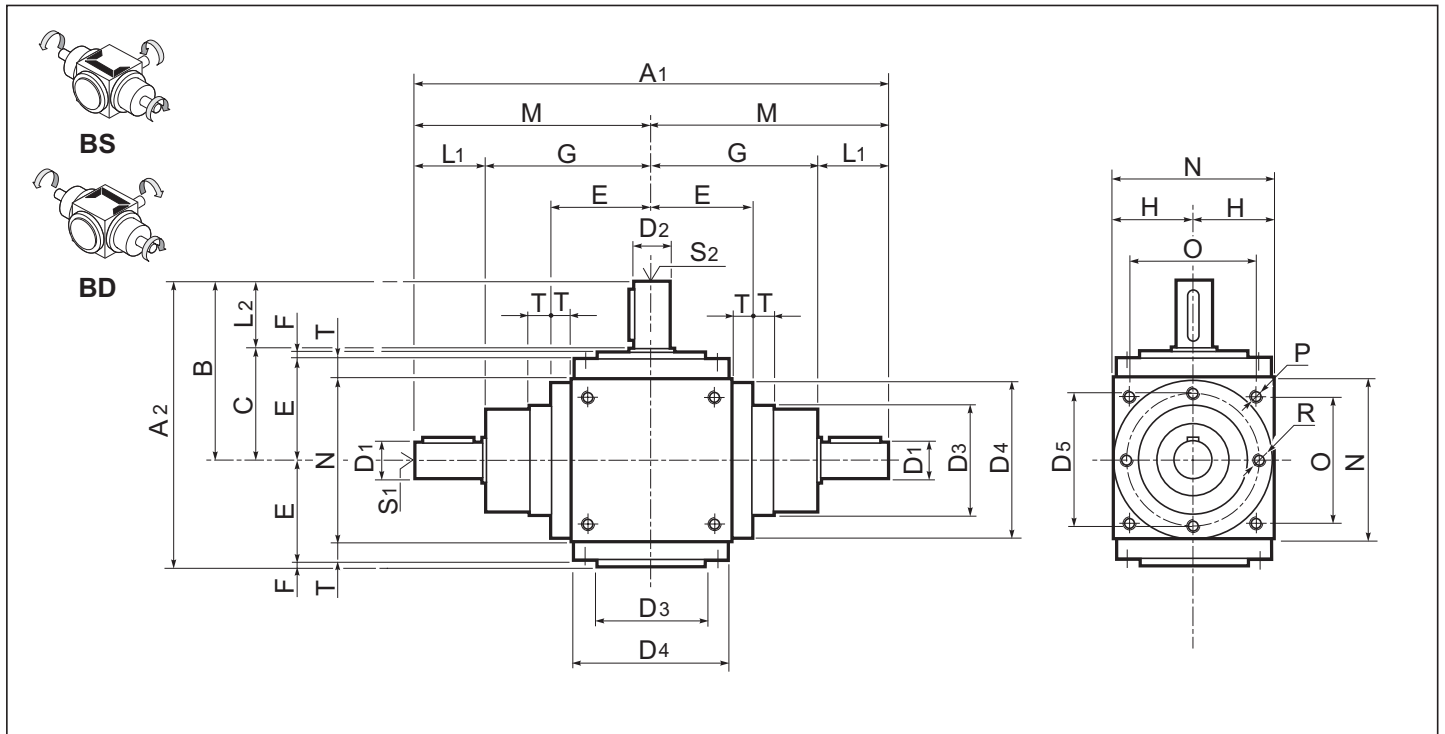

Z.MBS - Z.MBD

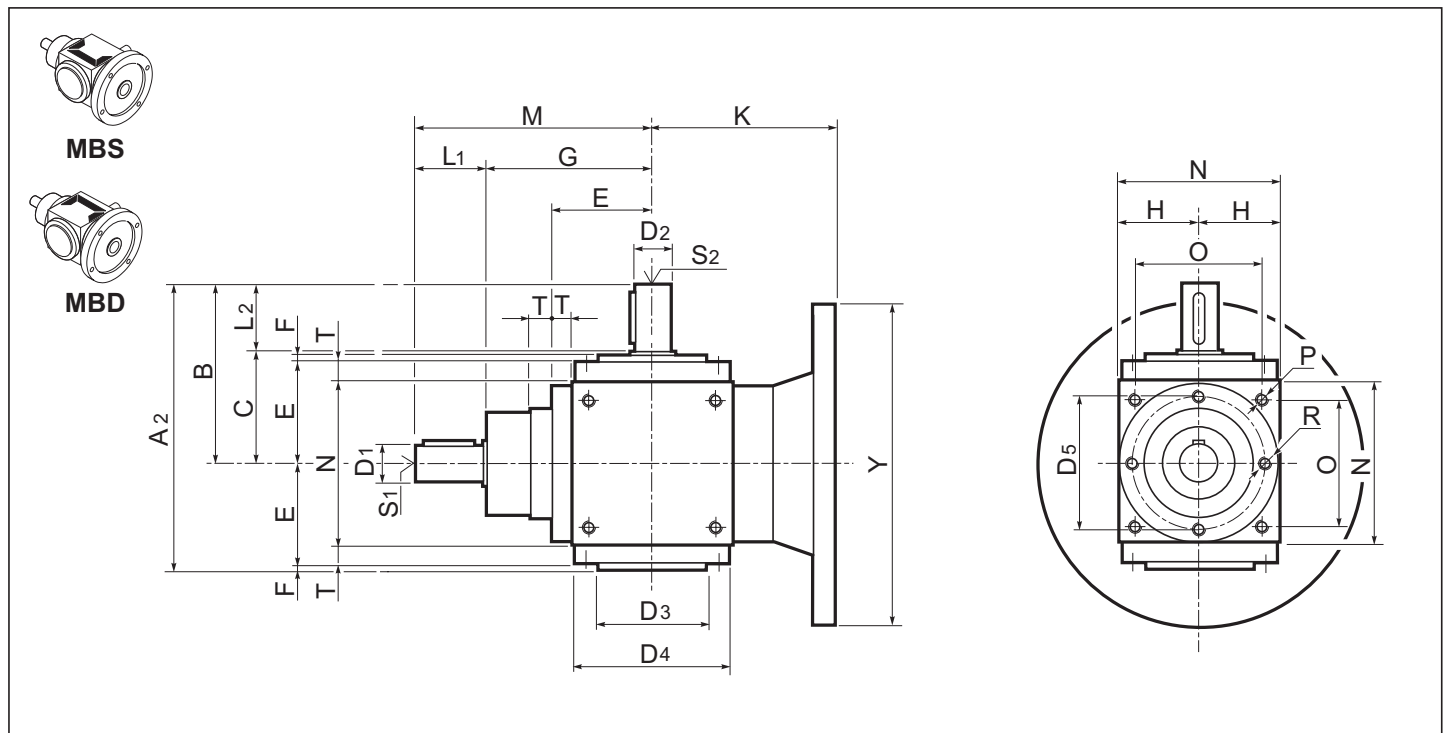

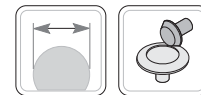

1.8 Dimensions

1.8 Dimensiones

1.8 Dimensões

Z.BS Z.BD	C	D3 h8	D4	D5	E	F	G	H	N	O	P	R	T
12	46	44	—	54	42	2	74	32.5	65	45	M6	M6	—
19	65	60	86	72	59	4	100	45	90	70	M6	M6	14
24	80	70	105	88	73	5	115	55	110	88	M8	M8	18
32	95	95	135	115	88	5	145	70	140	110	M10	M10	18
38	110	120	165	145	103	5	170	85	170	136	M12	M12	18
42	125	135	190	165	118	5	195	100	200	155	M12	M12	18
55	150	170	230	205	143	5	245	120	240	190	M14	M14	23
75	225	—	300	—	195	—	350	165	330	248	M16	M16	30

Z.BS Z.BD	ir	A1	A2	M	Arbre côté entrée / Eje entrada / Eixo entrada			Arbre côté sortie / Eje salida / Eixo saída		
					D1 j6	L1	S1	D2 j6	L2	S2
12	1-2-3	200	116	100	12	26	M4x8	12	26	M4x8
19	1-2-3	280	168	140	19	40	M6x12	19	40	M6x12
	4-5	260		130	14	30	M5x10			
24	1-2-3	330	208	165	24	50	M8x16	24	50	M8x16
	4-5	310		155	19	40	M6x12			
32	1-2-3	410	248	205	32	60	M10x20	32	60	M10x20
	4-5	390		195	24	50	M8x16			
38	1-2-3	480	288	240	38	70	M12x24	38	70	M12x24
	4-5	460		230	28	60	M10x20			
42	1-2-3	550	328	275	42	80	M12x24	42	80	M12x24
	4-5	510		255	32	60	M10x20			
55	1-2-3	710	408	355	55	110	M14x28	55	110	M14x28
	4-5	650		325	42	80	M12x24			
75	1-2-3	1000	598	500	75	150	M16x32	75	150	M16x32
	4-5	920		460	55	110	M14x28			

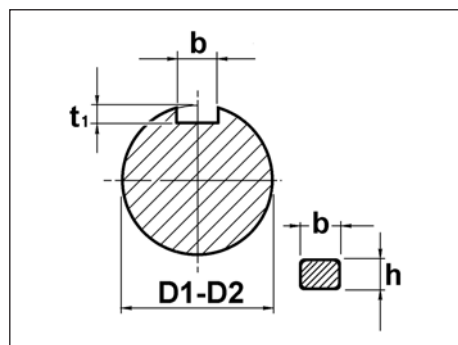

D1 - D2	b x h	t ₁
12	4 x 4	2.5
14	5 x 5	3.0
19	6 x 6	3.5
24	8 x 7	4.0
28	8 x 7	4.0
32	10 x 8	4.0
38	10 x 8	5.0
42	12 x 8	5.0
55	16 x 10	6.0
75	22 x 14	9.0

Z.MBS Z.MBD	IEC	12		19		24		32		38		42		55	
		Y	K	Y	K	Y	K	Y	K	Y	K	Y	K	Y	K
B5	105 (B14)	90	140	90	160	120	200	140	200	155	250	200	250	220	
	140	90	160	90	200	120	250	140	250	155	300	200	300	220	
							300		175		350	200	350	220	

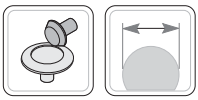

1.8 Dimensions

1.8 Dimensiones

1.8 Dimensões

Z.AH

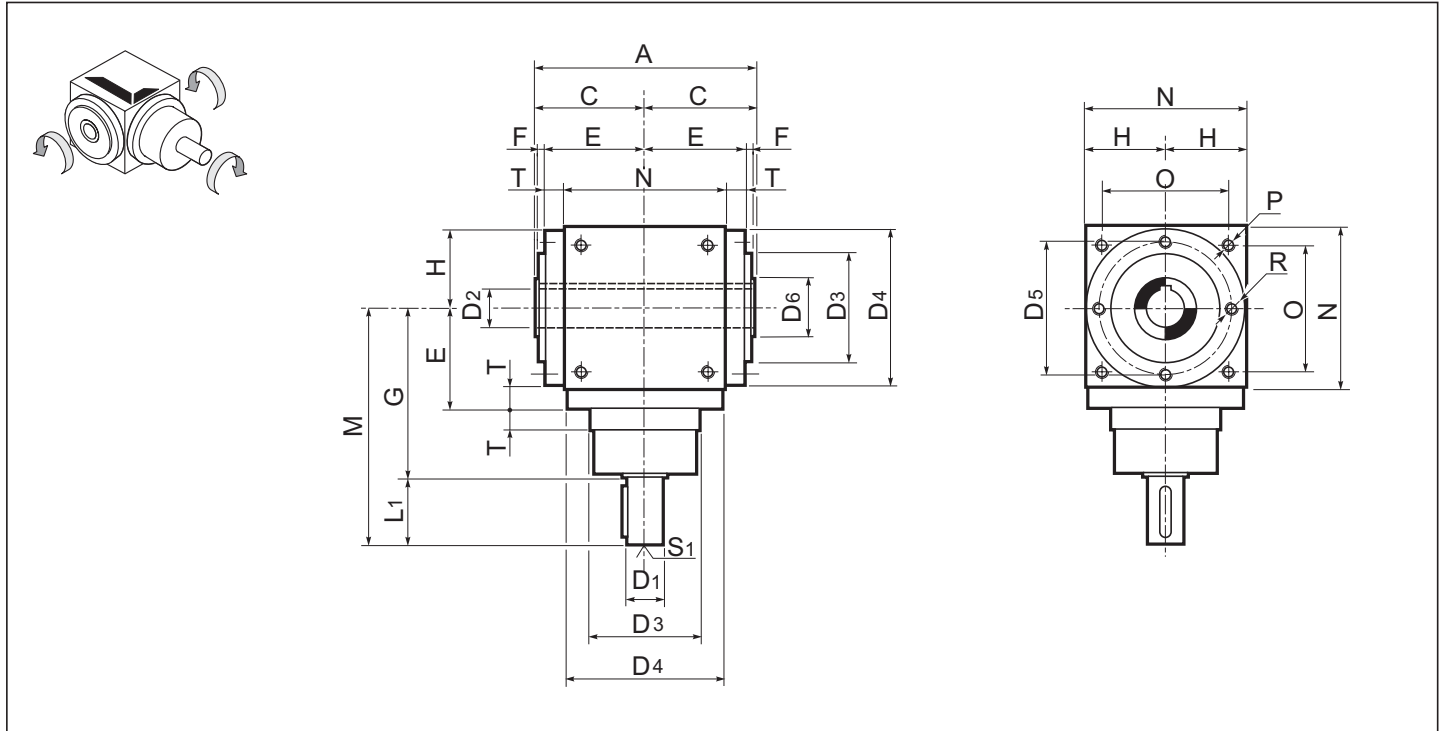

Z.MAH

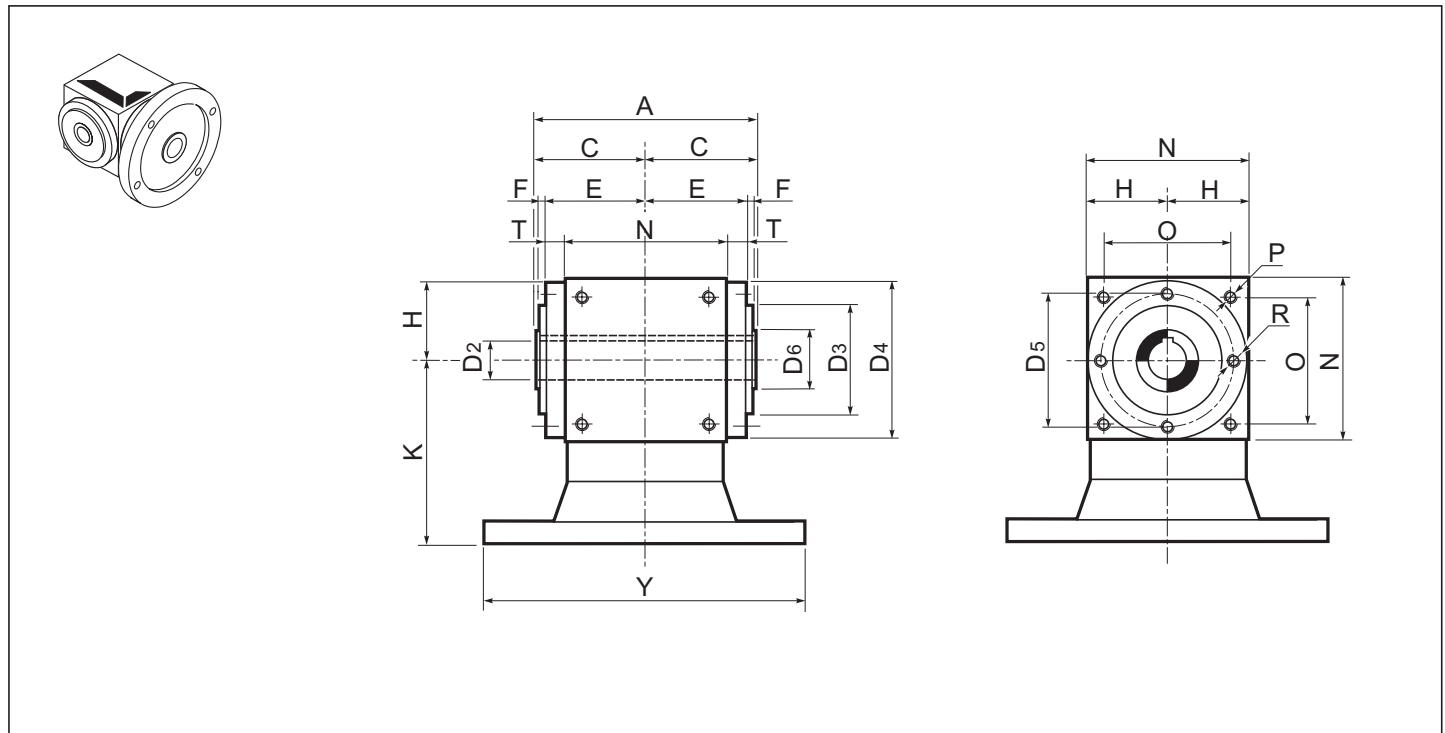



1.8 Dimensions

1.8 Dimensiones

1.8 Dimensões

Z.AH	C	D3 h8	D4	D5	D6	E	F	G	H	N	O	P	R	T
12	46	44 (h7)	65	54	—	42	2	74	32.5	65	—	—	76	9.5
19	65	60	86	72	30	59	4	100	45	90	70	M6	M6	14
24	80	70	105	88	35	73	5	115	55	110	88	M8	M8	18
32	95	95	135	115	50	88	5	145	70	140	110	M10	M10	18
38	110	120	165	145	60	103	5	170	85	170	136	M12	M12	18
42	125	135	190	165	60	118	5	195	100	200	155	M12	M12	18
55	150	170	230	205	75	143	5	245	120	240	190	M14	M14	23
75	225	—	300	—	120	195	—	350	165	330	248	M16	M16	30

Z.AH	ir	A	M	Arbre côté entrée / Eje entrada / Eixo entrada			Arbre côté sortie / Eje salida / Eixo saída
				D1 j6	L1	S1	D2 H7
12	1-2-3	92	100	12	26	—	12
19	1-2-3	130	140	19	40	M6x12	19
	4-5		130	14	30	M5x10	
24	1-2-3	160	165	24	50	M8x16	24
	4-5		155	19	40	M6x12	
32	1-2-3	190	205	32	60	M10x20	32
	4-5		195	24	50	M8x16	
38	1-2-3	220	240	38	70	M12x24	38
	4-5		230	28	60	M10x20	
42	1-2-3	250	275	42	80	M12x24	42
	4-5		255	32	60	M10x20	
55	1-2-3	300	355	55	110	M14x28	55
	4-5		325	42	80	M12x24	
75	1-2-3	450	500	75	150	M16x32	75
	4-5		460	55	110	M14x28	

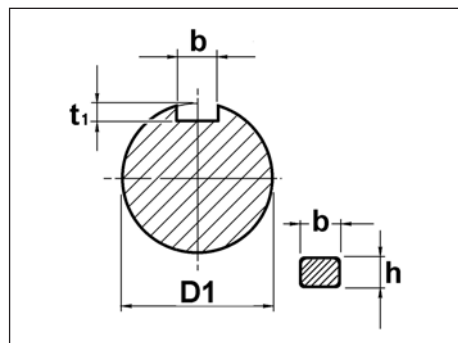

D1	b x h	t ₁
14	5 x 5	3.0 +0.1 0
19	6 x 6	3.5 0
24	8 x 7	4.0
28	8 x 7	4.0
32	10 x 8	4.0
38	10 x 8	5.0 +0.2 0
42	12 x 8	5.0
55	16 x 10	6.0
75	22 x 14	9.0

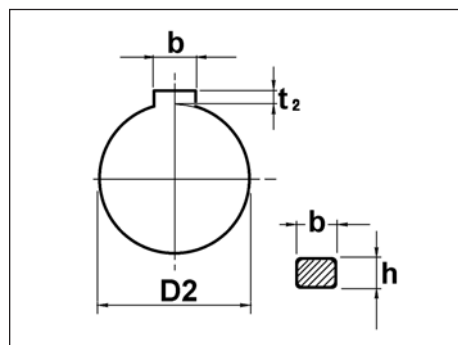

D2	b x h	t ₂
19	6 x 6	2.8 +0.1 0
24	8 x 7	3.3
32	10 x 8	3.3
38	10 x 8	3.3 +0.2 0
42	12 x 8	3.3
55	16 x 10	4.3
75	22 x 14	5.4

Z.MAH	IEC	12		19		24		32		38		42		55	
		Y	K	Y	K	Y	K	Y	K	Y	K	Y	K	Y	K
	B5	105 (B14)	90	140	90	160	120	200	140	200	155	250	200	250	220
		140	90	160	90	200	120	250	140	250	155	300	200	300	220
										300	175	350	200	350	220

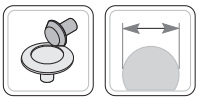

Z.BH

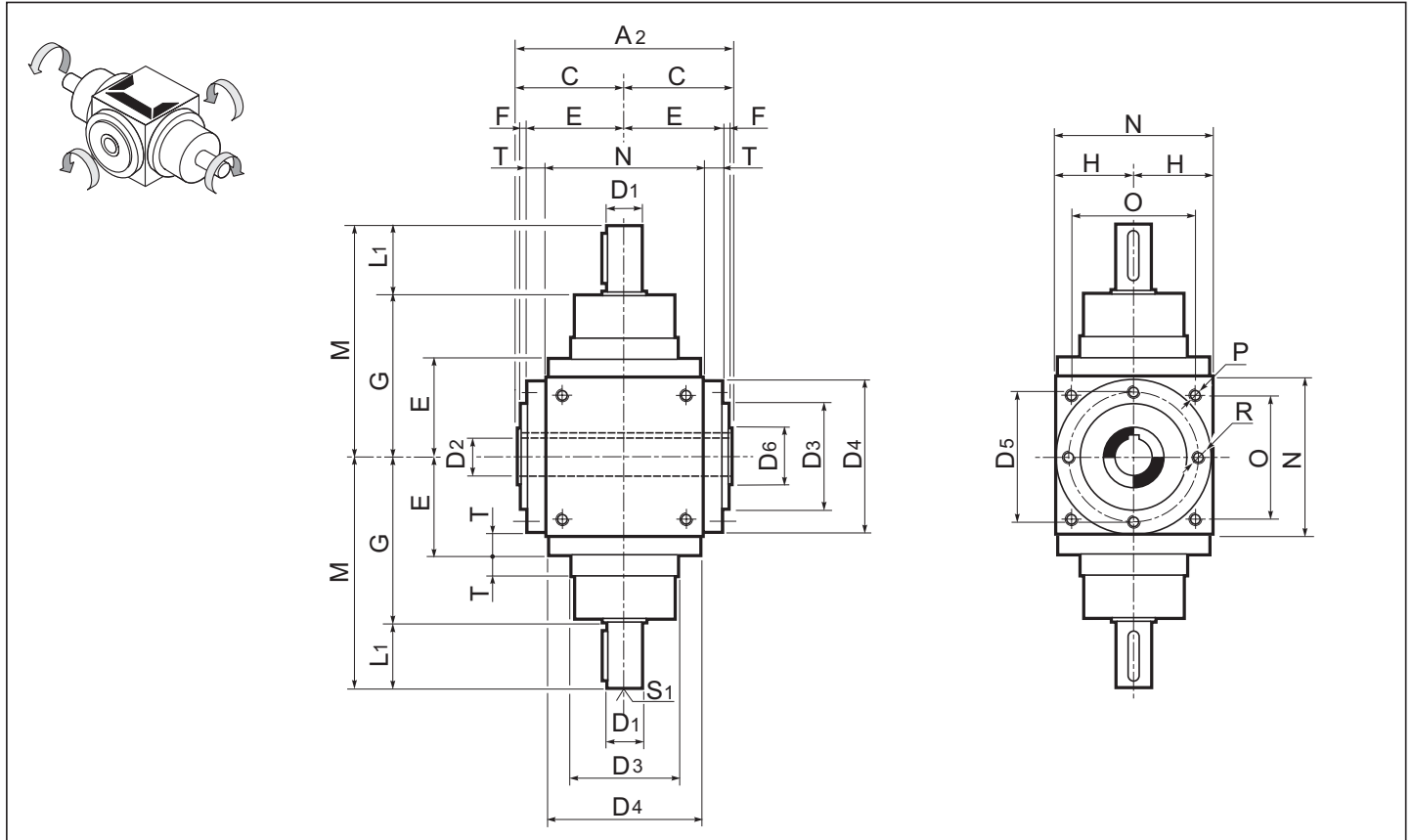

Z.MBH

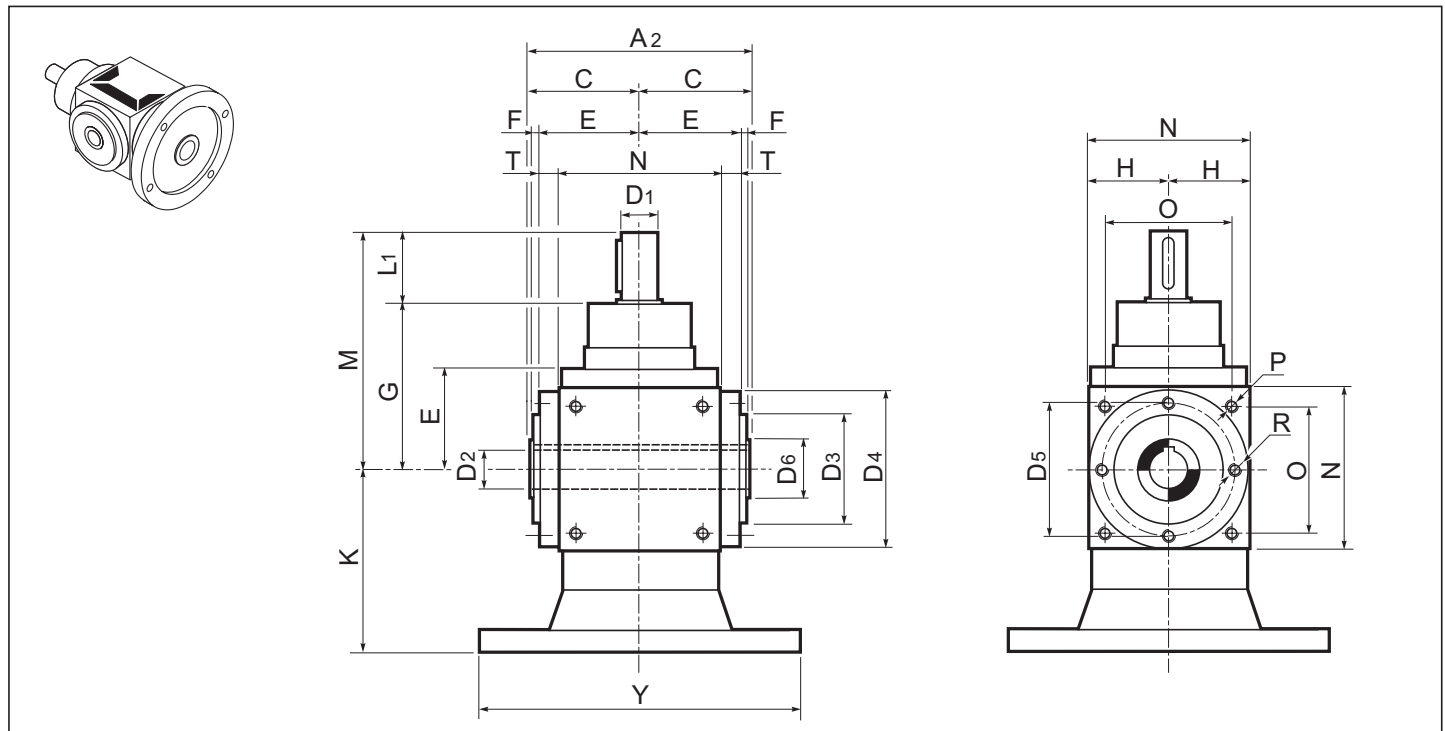



1.8 Dimensions

1.8 Dimensões

1.8 Dimensões

Z.BH	C	D3 h8	D4	D5	D6	E	F	G	H	N	O	P	R	T
12	46	44 (h7)	65	54	—	42	2	74	32.5	65	—	—	76	9.5
19	65	60	86	72	30	59	4	100	45	90	70	M6	M6	14
24	80	70	105	88	35	73	5	115	55	110	88	M8	M8	18
32	95	95	135	115	50	88	5	145	70	140	110	M10	M10	18
38	110	120	165	145	60	103	5	170	85	170	136	M12	M12	18
42	125	135	190	165	60	118	5	195	100	200	155	M12	M12	18
55	150	170	230	205	75	143	5	245	120	240	190	M14	M14	23
75	225	—	300	—	120	195	—	350	165	330	248	M16	M16	30

Z.BH	ir	A1	A2	M	Arbre côté entrée / Eje entrada / Eixo entrada			Arbre côté sortie / Eje salida / Eixo saída	
					D1 j6	L1	S1	D2 H7	
12	1-2-3	—	—	—	—	—	—	—	
19	1-2-3	280	130	140	19	40	M6x12	19	
	4-5	260		130	14	30	M5x10		
24	1-2-3	330	160	165	24	50	M8x16	24	
	4-5	310		155	19	40	M6x12		
32	1-2-3	410	190	205	32	60	M10x20	32	
	4-5	390		195	24	50	M8x16		
38	1-2-3	480	220	240	38	70	M12x24	38	
	4-5	460		230	28	60	M10x20		
42	1-2-3	550	250	275	42	80	M12x24	42	
	4-5	510		255	32	60	M10x20		
55	1-2-3	710	300	355	55	110	M14x28	55	
	4-5	650		325	42	80	M12x24		
75	1-2-3	1000	450	500	75	150	M16x32	75	
	4-5	920		460	55	110	M14x28		

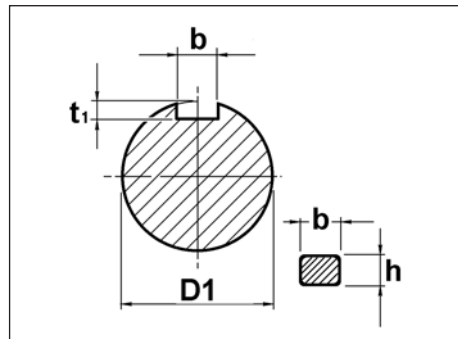

D1	b x h	t ₁
14	5 x 5	3.0 +0.1 0
19	6 x 6	3.5
24	8 x 7	4.0
28	8 x 7	4.0
32	10 x 8	4.0
38	10 x 8	5.0 +0.2 0
42	12 x 8	5.0
55	16 x 10	6.0
75	22 x 14	9.0

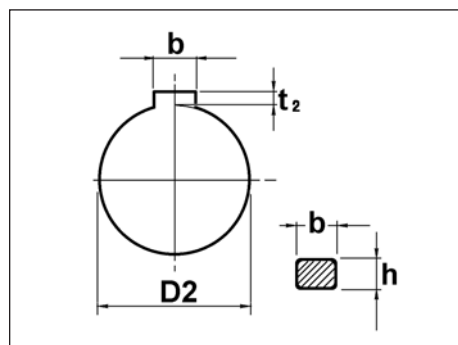

D2	b x h	t ₂
19	6 x 6	2.8 +0.1 0
24	8 x 7	3.3
32	10 x 8	3.3
38	10 x 8	3.3 +0.2 0
42	12 x 8	3.3
55	16 x 10	4.3
75	22 x 14	5.4

Z.MBH	IEC	12		19		24		32		38		42		55	
		Y	K	Y	K	Y	K	Y	K	Y	K	Y	K	Y	K
	B5	105 (B14)	90	140	90	160	120	200	140	200	155	250	200	250	220
		140	90	160	90	200	120	250	140	250	155	300	200	300	220
										300	175	350	200	350	220

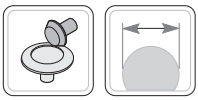

BRIDE D'ACCOUPLMENT FC / BRIDA DE ACOPLAMIENTO FC / FLANGE DE ACOPLAMENTO FC

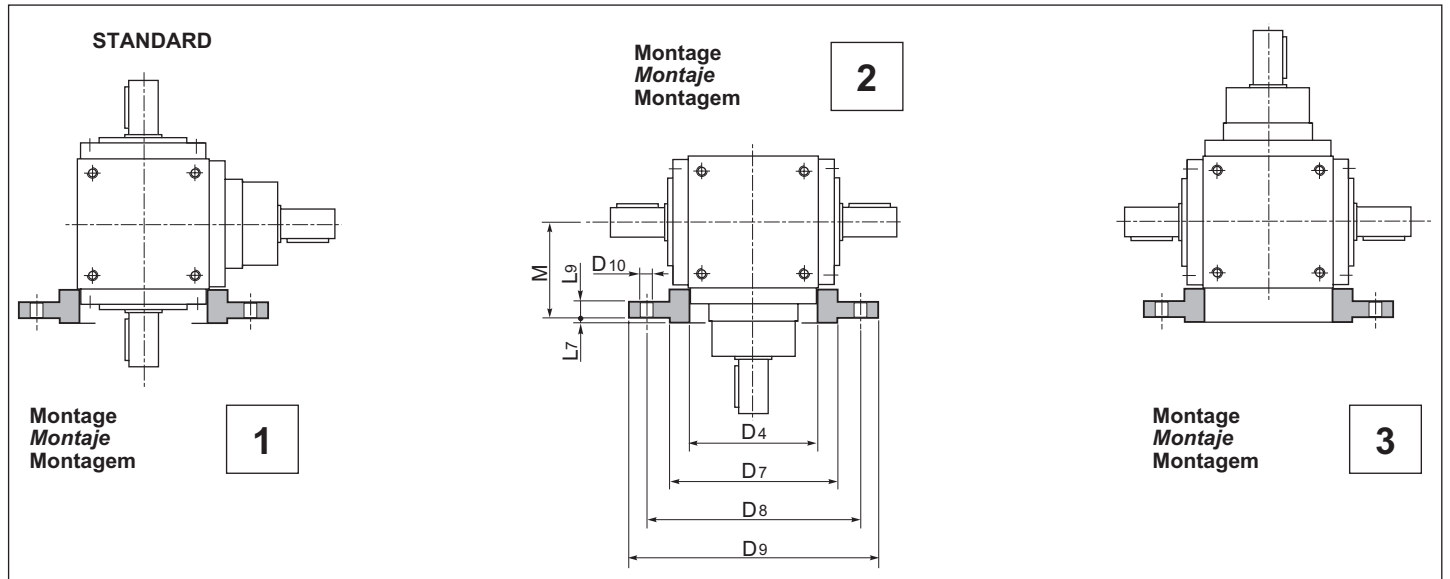

BRIDE D'ACCOUPLMENT FP / BRIDA DE ACOPLAMIENTO FP / FLANGE DE ACOPLAMENTO FC

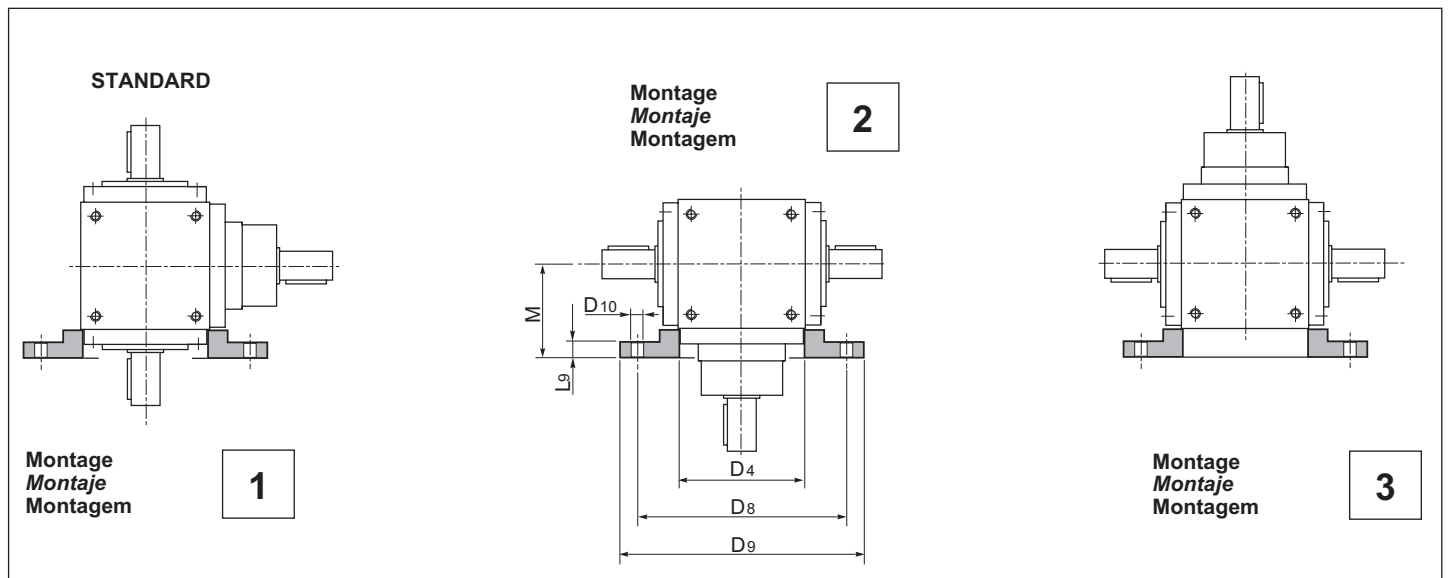

Z.	D4 H8	D7 h8	D8	D9	D10	L7	L9	M
12	—	—	—	—	—	—	—	—
19	86	110	130	160	9	3.5	12	70
24	105	130	165	200	11	3.5	13	85
32	135	180	215	250	14	4	15	105
38	165	230	265	300	14	4	15	125
42	190	230	265	300	14	4	15	145
55	230	250	300	350	18	5	18	175
75	300	350	400	450	18	5	25	230