



1.0 Riduttori - motoriduttori ortogonali ad assi sghembi S
1.0 The skew bevel helical gearboxes with skew axis S
1.0 Diese getriebemotore sind mit zwei spiralstirnradstufen mit schraege achsen hergestellt S

D

1.1	Caratteristiche tecniche	<i>Technical characteristics</i>	Technische Eigenschaften	D1
1.2	Designazione	<i>Designation</i>	Bezeichnungen	D2
1.4	Lubrificazione	<i>Lubrication</i>	Schmierung	D6
1.5	Carichi radiali e assiali	<i>Axial and overhung loads</i>	Radiale und Axiale Belastungen	D7
1.6	Prestazioni riduttori	<i>Gearboxes performances</i>	Leistungen der Getriebe	D8
1.7	Prestazioni motoriduttori	<i>Gearmotors performances</i>	Leistungen der Getriebemotoren	D10
1.8	Dimensioni	<i>Dimensions</i>	Abmessungen	D14
1.9	Accessori	<i>Accessories</i>	Zubehör	D19
1.10	Linguette	<i>Keys</i>	Paßfedern	D20



25 - 35 - 45

1.1 Caratteristiche tecniche

La fascia di bassa potenza non coperta dalla attuale gamma di riduttori ortogonali è da oggi disponibile con un inedito riduttore dal cinematismo brevettato.

Questo prodotto di nuovissima concezione ad ingranaggi elicoidali ad assi sghembi, riassume in un'unica macchina l'economicità del vite senza fine e l'alto rendimento degli ortogonali a coppia conica.

Le 3 taglie coprono un range di coppia da 100 Nm a 250 Nm, fornendo ad ogni applicazione il giusto prodotto per ottimizzare il rapporto coppia/costo.

1.1 Technical characteristics

The low power bevel helical gearbox range, which was unavailable until today, is now ready by means of a brand new type of gearbox for which mechanical system STM has been given the copyright.

This very new and innovative gearbox relies on helical gears with oblique shafts and puts together in a single conception the economical cost typical worm gearboxes and high efficiency typical of bevel helical gearboxes with right angle pair.

The 3 sizes being planned cover a torque range ranging from 100 Nm a 250 Nm and will supply every application the best product to optimise ratio torque/cost.

1.1 Technische Eigenschaften

Der Bereich der Low-Power, der nicht durch die aktuelle Auswahl an Winkelgetrieben abgedeckt wird, ist jetzt mittels eines neuen patentierten kinematischen Getriebes verfügbar. Diese allerneueste Konzeption der Schrägzahnräder, vereint in einer Maschine die Wirtschaftlichkeit des Schneckengetriebes mit der hohen Leistung des Kegelstirnradgetriebes.

Die drei Baugrößen decken einen Drehmomentbereich von 100 Nm bis 250 Nm ab und bieten somit für jede Anwendung das richtige Produkt zur Optimierung des Verhältnisses Drehmoments/Kosten.



1.2 Designazione

1.2 Designation

1.2 Bezeichnung

Maschine	Input Version	Size	Output Flange	Mounting Position Output Flange	Output Shaft	Shaft Diameter	Mounting Shaft	Reduction ratio	Input Shaft	Designazione Motori Designation Motors Bezeichnung Motoren	Input double extension	Mounting positions	Position Terminal Box	WEB: Reference Designation
00 M	01 IV	02 SIZE	03 OF	04 MPOF	05 OS	07 SD	08 MS	09 IR	11 IS	12 BE	13 MP	15 PMT		
S	M	25 35 45	—	—	—	— Nessuna indicazione diametro standard No indications standard diameter Keine Angabe Standard-durchmesser Ø... Diametro foro opzionale Optional hollow shaft diameter Optionaler Hohlwellen durchmesse	—	— Vedi tabelle prestazioni See performance tables Siehe Leistungstabellen	80B5 80B14 ...	—	—	M1 M2 M3 M4 M5 M6	1 2 3 4	SM 45 1:10 80B5
			—						Look CT 18	SM 45 1:10 T 80 B 4 B5				
			—						—	—				
			—						—	S 45 1:10				

00 M - Macchina

M - Maschine

M - Getriebe



S

01 IV - Versione Entrata

IV - Input Version

IV - Antriebsausführung

M		—	
			25
			35
			45

Disponibile / available / verfügbar

02 SIZE - Grandezza

SIZE - Size

SIZE - Größe

25	35	45
----	----	----

Senso di Rotazione
Rotation sense
Drehrichtung



03 OF - Flangia Uscita

OF - Output Flange

OF - Flansche am Abtrieb

—	F.																			
	Flangia Uscita F. / Output Flange F. / Flansche am Abtrieb F.																			
Senza Flangia Without Flange Ohne Flansche	<table border="1"> <tr> <td></td> <td>25</td> <td>35</td> <td>45</td> </tr> <tr> <td>F1</td> <td>FA</td> <td>F1</td> </tr> <tr> <td>F2</td> <td>FB</td> <td>F2</td> </tr> <tr> <td>F3</td> <td>-</td> <td>FL</td> </tr> <tr> <td>FL</td> <td>-</td> <td>-</td> </tr> <tr> <td>*FA</td> <td>-</td> <td>-</td> </tr> </table>		25	35	45	F1	FA	F1	F2	FB	F2	F3	-	FL	FL	-	-	*FA	-	-
		25	35	45																
	F1	FA	F1																	
	F2	FB	F2																	
	F3	-	FL																	
FL	-	-																		
*FA	-	-																		
	(*) A richiesta / Upon Request / Auf Anfrage																			



1.2 Designazione

1.2 Designation

1.2 Bezeichnung

04 MPOF - Lato Flangia Uscita

MPOF - Mounting Position Output Flange

MPOF - Montageseite Abtriebsflansch

— Nessuna indicazione = flangia uscita con montaggio destro.
S = flange uscita con montaggio sinistro.

— *No indication (standard) = output flange on right side;*
S = *output flange on left side.*

— Keine Angabe (Standard) = Abtriebsflansch rechts.
S = Abtriebsflansch links.

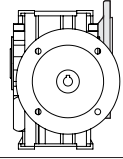
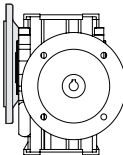
—	Flangia in uscita a destra Output flange on right side Flansch am Abtriebe rechts	
S	Flangia in uscita a sinistra Output flange on left side Flansch am Abtrieb links	

05 OS - Estremità uscita

OS - Output shaft

OS - Wellenende - Abtrieb



— Nessuna indicazione = albero forato;
C = albero forato con calettatore
B = albero bisporgente integrale

— *No indication = hollow shaft with keyway;*
C = *hollow shaft with shrink disk*
B = *Double integral output shaft*

— Keine Angabe = Hohlwelle mit Paßfedernut
C = Hohlwelle mit Schrumpfscheibe
B = Doppeltem Integralwelle

07 SD - Diametro albero



SD - Shaft diameter

SD - Durchmesser Abtriebswelle

— Nessuna indicazione = diametro standard;
diametro opzionale = vedi tabella.

— *No indications = standard diameter;*
optional diameter = *see table.*

— Keine Angabe = Standard-durchmesser
Optionaler durchmesser = *siehe Tabelle.*

						
	Standard	Optional	Standard	Optional	Standard	Optional
	—	Ø...	—	Ø...	—	Ø...
25	(Ø 19)	Ø 20 Ø 24	(Ø 19)	not available	Ø 19	not available
35	(Ø 25)	Ø 28 Ø 30	(Ø 25)		Ø 25	
45	(Ø 30)	Ø 28 Ø 25	(Ø 30)		Ø 30	

08 MS - Posizione Albero

MS - Mounting Shaft

MS - Montageposition Welle

— Nessuna indicazione = lato destro (standard);
S = lato sinistro, montaggio dalla parte opposta (opzionale).

— *No indication (standard) = on right side;*
S = *on left side, on the opposite.*

— Keine Angabe (Standard) = rechts;
S = links.

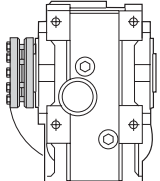
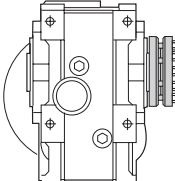
Albero forato con calettatore Hollow shaft with shrink disc Holwelle mit Schrumpfscheibe		S		—	
--	---	----------	--	---	---



1.2 Designazione

1.2 Designation

1.2 Bezeichnung

09 IR- Rapporto di riduzione

(Vedi prestazioni). Tutti i valori dei rapporti sono approssimati. Per applicazioni dove necessita il valore esatto consultare il ns. servizio tecnico.

IR - Reduction ratio

(See ratings). Ratios are approximate values. If you need exact values for a specific application, please contact our Engineering.

IR - Übersetzungsverhältnis

(Siehe "Leistungen"). Bei allen Werten der Übersetzungen handelt es sich um approximative Wertangaben. Bei Applikationen, bei denen die exakte Wertangabe erforderlich ist, muss unser Technischer Kundendienst konsultiert werden.

11 IS - Albero Entrata

Nella tab. sono riportate le grandezze motore accoppiabili (IEC) unitamente alle dimensioni albero/flangia motore standard

Legenda:

11/140 (B5): combinazioni albero/flangia standard

11/120 : combinazioni albero/flangia a richiesta

IS - Input Shaft

In table the possible shaft/flange dimensions IEC standard are listed.

Key:

11/140 : standard shaft/flange combination

11/120 : shaft/flange combinations upon request

IS - Antriebswelle

In Tabelle sind die möglichen Welle/Flansch-Abmessungen IEC-Standard aufgelistet.

Legende:

11/140 : Standardkombinationen Welle/Flansch

11/120 : Sonderkombinationen Welle/Flansch

Possibili accoppiamenti con motori IEC - Possible couplings with IEC motors - Mögliche Verbindungen mit IEC-Motoren

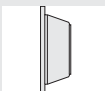
		 SM		
	IEC			Tipo entrata Type Input Antriebtyp
SM25	90 ⁽²⁾	24/200 (B5) - 24/140 (B14) 24/160 - 24/120 - 24/105• - 24/90•		Without coupling ir (Only 8-10-14)
	80 ⁽¹⁾	19/200 (B5) - 19/120 (B14) 19/160 - 19/140 - 19/105• - 19/90•		With coupling ir (Tutti / All / Alle)
	71	14/160 (B5) - 14/105• (B14) 14/200 - 14/140 - 14/120 - 14/90•		
	63	11/140 (B5) - 11/90• (B14) - 11/200 - 11/160 - 11/120 - 11/105•		
SM 35	90 ⁽¹⁾	24/200 (B5) - 24/140 (B14) 24/160 - 24/120 - 24/105•		With coupling ir (Tutti / All / Alle)
	80	19/200 (B5) - 19/120 (B14) 19/160 - 19/140 - 19/105•		
	71	14/160 (B5) - 14/105• (B14) 14/200 - 14/140 - 14/120		
SM45	112 ⁽²⁾	28/160 (B14)		Without coupling ir (Only 8-10-14-16)
	100 ⁽²⁾	28/160 (B14)		
	90 ⁽¹⁾	24/200 (B5) - 24/140 (B14) 24/160 - 24/120 - 24/105•		With coupling ir (Tutti / All / Alle)
	80	19/200 (B5) - 19/120 (B14) 19/160 - 19/140 - 19/105•		
	71	14/160 (B5) - 14/105• (B14) 14/200 - 14/140 - 14/120		

⁽¹⁾ **ATTENZIONE!-WARNING!-ACHTUNG!** (Vedere paragrafo 1.12-Sezione A)/(Look at chapter 1.12-Section A)/(s. S. 1.12-Abschnitt A)

⁽²⁾ A richiesta / Upon Request / Auf Anfrage



Posizione morsetti - Vedere - 15 - PMT - Pagina D5
Terminal board position - Look - 15 - PMT - Page D5
Lage des Klemmenkastens - Siehe - 15 - PMT - Auf Seite D5

Designazione motore elettrico
Se è richiesto un motoriduttore completo di motore è necessario riportare la designazione di quest'ultimo.
A tale proposito consultare il ns. catalogo dei motori elettrici Electronic Line.

Electric motor designation
For applications requiring a gearmotor, motor designation must be specified. To this end, please refer to our Electronic Line electric motor catalogue.

Bezeichnung des Elektromotors
Wird ein Getriebemotor komplett mit Elektromotor angefordert, müssen dessen Daten angegeben werden.
Diesbezüglich verweisen wir auf unseren Katalog der Elektromotoren "Electronic Line".



1.2 Designazione

1.2 Designation

1.2 Bezeichnung

12 BE - Bisporgenza Entrata

BE - Input double extension

BE - Doppelantrieb

Nessuna indicazione = ingresso senza bisporgenza;
B = entrata con bisporgenza.

No indication = no double extension
B = input double extension

Keine Beschreibung = kein Doppelantrieb
B = Doppelantrieb

13 MP - Posizioni di montaggio

MP - Mounting positions

MP - Einbaulagen

[M2, M3, M4, M5, M6] Posizioni di montaggio con indicazione dei tappi di livello, carico e scarico; se non specificato si considera standard la posizione M1 (vedi par. 1.4)

[M2, M3, M4, M5, M6] Mounting position with indication of breather level and drain plugs; if not specified, standard position is M1 (see par. 1.4).

Montageposition [M2, M3, M4, M5, M6] mit Angabe von Entlüftung, Schaugläsern und Ablassschraube. Wenn nicht näher spezifiziert, wird die Standard - position M1 zugrunde gelegt (s. Abschnitt 1.4).

14 OPT-ACC. - Opzioni

OPT-ACC - Options

OPT-ACC. - Optionen

vedi par. 1.9 see pa. 1.9 s. Abschnitt 1.9	ACC1	AL	Alberi lenti - AL	Output shafts - AL	Abtriebswellen - AL
		PROT.	Coperchio di protezione	Protection cover	Schultzvorrichtungdeckel
	ACC3	BRS	Braccio Reazione Semplice	Torque arm - Single	Drehmomentstütze - Normal
		BRS_VKL	Braccio Reazione Semplice_con boccola_VKL	Torque arm - Single_with VKL_bushing	Drehmomentstütze - Normal_mit VKL - Buchse

vedi Sezione A-1.12 see Section A-1.12 s. Abschnitt A-1.12	OPT.	OPT	Materiale degli anelli di tenuta	Materials of Seals	Dichtungsstoffe
		OPT1	Stato fornitura olio	Scope of the supply - Options - OIL	Optionen - Lieferzustand - Optionen - Öl
		OPT2	Verniciatura	Painting and surface protection	Lackierung und Oberflächenschutz

15 PMT - Posizioni della Morsettiera

PMT - Position Terminal Box

PMT - Montagposition Klemmenkasten

[2, 3, 4] Posizione della morsettiera del motore se diversa da quella standard (1).

[2, 3, 4] Position of the motor terminal box if different from the standard one (1).

Montageposition Klemmenkasten [2, 3, 4], wenn abweichend von Standardposition [1] (für Motorgetriebe).

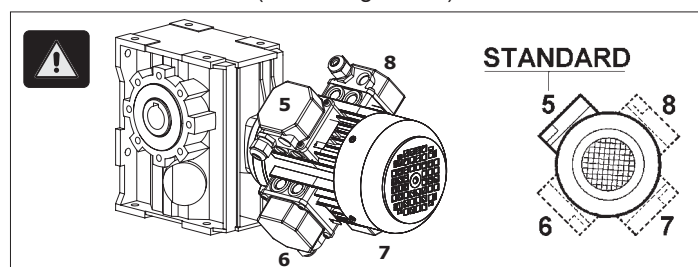
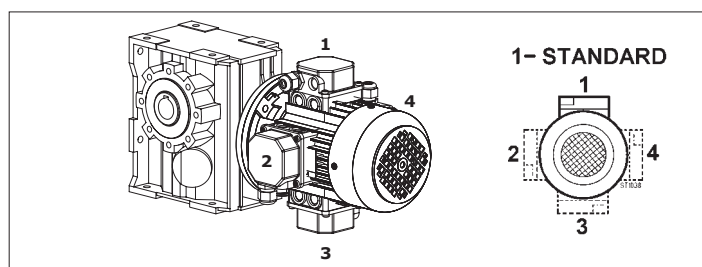

N.B.
 La configurazione standard della flangia attacco motore prevede 4 fori a 45°.

Note.
 The standard configuration for the 4 holes is 45° to the axles (like an x: see par 2.3).

Per le flange contrassegnate con il simbolo (*) (vedi pagina D4) i fori per il fissaggio al motore sono disposti in croce (esempio +). Pertanto è opportuno valutare l'ingombro della morsettiera del motore che verrà installato in quanto essa verrà a trovarsi orientata a 45° rispetto agli assi. Per la scelta della posizione della morsettiera rispetto agli assi fare riferimento allo schema seguente (in cui la posizione 5 è quella standard):

For the B14 flanges marked with (*) (see page D4) the holes to fit the motor are on the axles (like a +). Therefore we suggest to check the dimensions of the terminal board of the motor as it will be at 45° to the axles. Please choose the terminal board position referring to the following sketch (in which n° 5 is the standard position):

HINWEIS.
 In der Standardkonfiguration sind die 4 Flanschbohrungen im 45°-Winkel zu den Achsen angeordnet
 Bei B14-Flanschen, die mit (*) (Siehe auf Seite D4) gekennzeichnet sind, sind die Bohrungen auf den Achsen angeordnet (wie ein +). Es sollte deshalb der Platzbedarf des Motorklemmenkastens beachtet werden, da er sich in 45°-Position zu den Achsen befindet wird. Die Lage des Klemmenkastens des Motors wählen Sie bitte anhand der folgenden Skizze (Pos. 5 ist Standardposition):



1.4 Lubrificazione

1.4 Lubrication

1.4 Schmierung



Posizioni di montaggio
Mounting positions
Montagepositionen

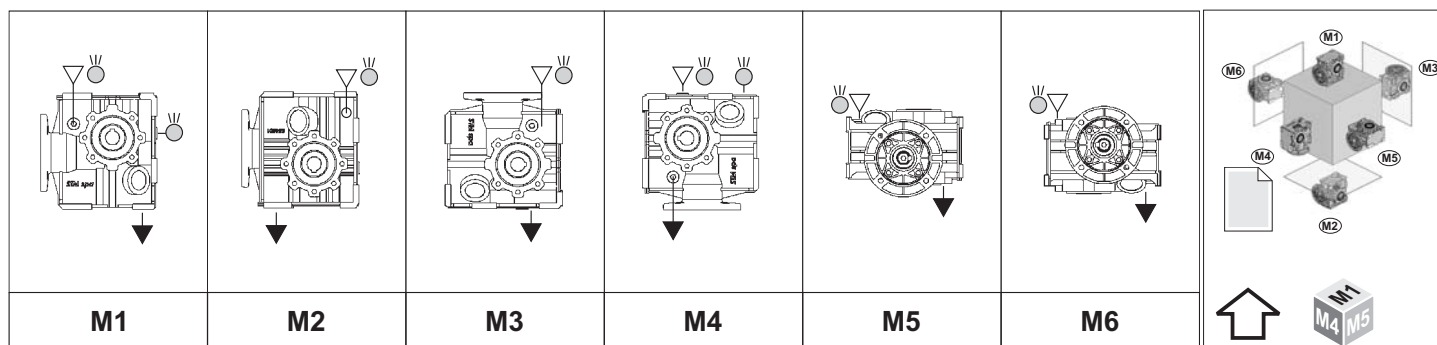

- ▽ Carico / Breather plug / Einfüll-u. Entlüftungsschraube
- Livello / Level plug / Schauglas
- ▼ Scarico / Drain plug / Ablassschraube
- ⊕ Sfiato / Vent plug / Entlüftungsstopfen

SM	Posizioni di montaggio - Mounting positions - Montagepositionen		Prescrizioni da indicare in fase d'ordine Ordering requirements Anforderungen bei der Bestellung
		Posizioni Positions Positionen	
	25	M1-M2	Necessaria Necessary Erforderlich
	35	M3-M4	
	45	M5-M6	

TARGHETTA - RIDUTTORE

NON NECESSARIA

Indicata sempre nella targhetta del riduttore la posizione di montaggio "M1".

NECESSARIA

La posizione richiesta è indicata nella targhetta del riduttore

Identification Plate - Gearbox

NOT NECESSARY

The mounting position is always indicated on the nameplate "M1".

NECESSARY

The indication it on the label of the gearbox

Typeschild - Getriebe

NICHT ERFORDERLICH

Die Einbaulage ist immer auf dem Typenschild angegeben "M1".

ERFORDERLICH

Findet man die angefragte Position auf dem Typenschild des Getriebe

Lub	Quantità di lubrificante - Lubricant Quantity - Schmiermittelmenge - [Kg]								OPT1	Tappi-Plug-Stopfen		
		M1	M2	M3	M4	M5	M6	N°		Diameter	Type	
SM	25	0.300	0.480	0.480	0.480	0.480	0.480	INOIL_STD	2	1/8"		
	35	0.400	0.580	0.580	0.580	0.580	0.580		2	1/8"		
	45	0.500	0.850	0.800	0.800	0.800	0.800		3	1/4"		

Attenzione !:
Il tappo di sfiato è allegato su tutte le grandezze dei riduttori

Warning!:
Breather plug is enclosed with every gearbox size and must be installed prior to operation

Achtung!:
Der Entlüftungsstopfen wird mitgeliefert und muss vor der Benutzung des Getriebes eingebaut werden.

Nota: Se in fase d'ordine la posizione di montaggio è omessa, il riduttore verrà fornito con i tappi predisposti per la posizione M1.

Note: If the mounting position is not specified in the order, the worm gearbox supplied will have plugs pre-arranged for position M1.

Anmerkung: Sollte in der Auftragsphase die Einbaulage nicht angegeben werden, wird das Getriebe mit Stopfen für die Einbaulage M1.

Eventuali forniture con predisposizioni tappi diverse da quella indicata in tabella, dovranno essere concordate.

The supply of gearboxes with different plug pre-arrangements has to be agreed with the manufacturer.

Lieferungen, die eine Auslegung hinsichtlich der Stopfen aufweisen, die von den Angaben in der Tabelle abweichen, müssen vorab vereinbart werden.



1.5 Carichi radiali e assiali

Quando la trasmissione del moto avviene tramite meccanismi che generano carichi radiali sull'estremità dell'albero, è necessario verificare che i valori risultanti non eccedono quelli indicati nelle tabelle.

In Tab. 2.6 sono riportati i valori dei carichi radiali ammissibili per l'albero lento (F_{r2}). Come carico assiale ammissibile contemporaneo si ha:

$$F_{a2} = 0.2 \times F_{r2}$$

1.5 Axial and overhung load

Should transmission movement determine radial loads on the angular shaft end, it is necessary to make sure that resulting values do not exceed the ones indicated in the tables.

In Table 2.6 permissible radial loads for output shaft are listed (F_{r2}). Permissible axial load is given by the following formula:

$$F_{a2} = 0.2 \times F_{r2}$$

1.5 Radiale und axiale Belastungen

Wird das Wellenende auch durch Radialkräfte belastet, so muß sichergestellt werden, daß die resultierenden Werte die in der Tabelle angegebenen nicht überschreiten.

In Tabelle 2.6 sind die Werte der zulässigen Radialbelastungen für die Abtriebswelle (F_{r2}) angegeben. Als zulässige Axialbelastung gilt:

$$F_{a2} = 0.2 \times F_{r2}$$

Tab. 2.6

n_2 [min ⁻¹]	F_{r2} [N]		
	SM 25	SM 35	SM 45
400	1000	1250	1500
320	1000	1250	1750
260	1050	1313	1950
200	1100	1375	2050
160	1300	1625	2250
125	1300	1625	2400
90	1800	2250	2750
60	1800	2250	2900
40	1800	2250	3300
25	2300	2875	4000
16	2300	2875	4500
10	2800	3500	5300
5	3000	3750	6400

I carichi radiali indicati nelle tabelle si intendono applicati a metà della sporgenza dell'albero lento standard e sono riferiti ai riduttori operanti con fattore di servizio 1. Per i carichi non agenti sulla mezzzeria dell'albero lento o veloce si ha:

- a 0.3 della sporgenza:
 $F_{rx} = 1.25 \times F_{r1-2}$
- a 0.8 dalla sporgenza:
 $F_{rx} = 0.8 \times F_{r1-2}$

The radial loads shown in the tables are applied on the middle of standard shaft extensions. Base of these values is a service factor 1. For radial loads which are not applied on the middle of the shafts, the following values can be calculated:

- at 0.3 from extension:
 $F_{rx} = 1.25 \times F_{r1-2}$
- at 0.8 from extension:
 $F_{rx} = 0.8 \times F_{r1-2}$

Bei den in der Tabelle angegebenen Radialbelastungen wird eine Kräfteinwirkung auf die Mitte der Standardwelle angenommen; außerdem wird ein Betriebsfaktor 1 zugrunde gelegt. Ist die Einwirkung der Radialkraft nicht in der Mitte der Welle, so können die zulässigen Radiallasten folgendermaßen ermittelt werden:

- 0.3 vom Wellenabsatz entfernt:
 $F_{rx} = 1.25 \times F_{r1-2}$
- 0.8 vom Wellenabsatz entfernt:
 $F_{rx} = 0.8 \times F_{r1-2}$

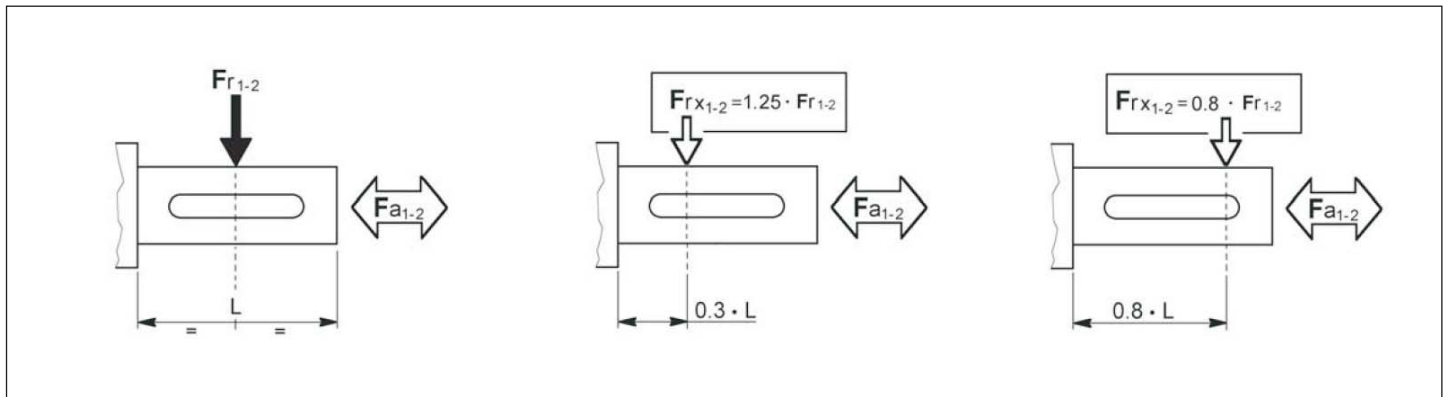



1.6 Prestazioni riduttori SM

1.6 SM gearboxes performances

1.6 Leistungen der SM-Getriebe

SM 25



5

ir	$n_1 = 2800 \text{ min}^{-1}$				$n_1 = 1400 \text{ min}^{-1}$				$n_1 = 900 \text{ min}^{-1}$				IEC
	n_2	T_{2M}	P	RD	n_2	T_{2M}	P	RD	n_2	T_{2M}	P	RD	
	min^{-1}	Nm	kW	%	min^{-1}	Nm	kW	%	min^{-1}	Nm	kW	%	
8	350	67	2,71	90	175	70	1,43	90	113	74	0,96	90	90 B5 90 B14
10	280	81	2,63	90	140	85	1,38	90	90	89	0,93	90	
14	200	95	2,21	90	100	100	1,16	90	64	105	0,79	90	
18	156	95	1,72	90	78	100	0,90	90	50	105	0,61	90	
20	140	95	1,55	90	70	100	0,81	90	45	105	0,55	90	
25	112	95	1,24	90	56	100	0,65	90	36	105	0,44	90	
35	80	95	0,88	90	40	100	0,47	90	26	105	0,31	90	
45	62	95	0,69	90	31	100	0,36	90	20	105	0,24	90	
50	56	95	0,62	90	28	100	0,33	90	18	105	0,22	90	
56	50	95	0,55	90	25	100	0,29	90	16	105	0,20	90	
72	39	95	0,43	90	19	100	0,23	90	13	105	0,15	90	
80	35	95	0,39	90	18	100	0,20	90	11	105	0,14	90	
90	31	95	0,34	90	16	100	0,18	90	10	105	0,12	90	
100	28	95	0,31	90	14	100	0,16	90	9	105	0,11	90	

P_{tN} [kW]	tutti i rapporti all ratios alle Untersetzungen
	1.6

SM 35



7.5

ir	$n_1 = 2800 \text{ min}^{-1}$				$n_1 = 1400 \text{ min}^{-1}$				$n_1 = 900 \text{ min}^{-1}$				IEC
	n_2	T_{2M}	P	RD	n_2	T_{2M}	P	RD	n_2	T_{2M}	P	RD	
	min^{-1}	Nm	kW	%	min^{-1}	Nm	kW	%	min^{-1}	Nm	kW	%	
8	350	86	3,48	90	175	90	1,83	90	113	95	1,24	90	90 B5 90 B14
10	280	109	3,56	90	140	115	1,87	90	90	121	1,26	90	
12,5	224	138	3,59	90	112	145	1,89	90	72	152	1,28	90	
14	200	138	3,21	90	100	145	1,69	90	64	152	1,14	90	
18	156	138	2,49	90	78	145	1,31	90	50	152	0,89	90	
20	140	138	2,24	90	70	145	1,18	90	45	152	0,80	90	
25	112	166	2,17	90	56	175	1,14	90	36	180	0,75	90	
29,75	94	162	1,77	90	47	170	0,93	90	30	180	0,63	90	
35	80	166	1,55	90	40	175	0,81	90	26	180	0,54	90	
45	62	157	1,13	90	31	165	0,60	90	20	173	0,40	90	
50	56	157	1,02	90	28	165	0,54	90	18	173	0,36	90	
56	50	157	0,91	90	25	165	0,48	90	16	173	0,32	90	
63	44	157	0,81	90	22	165	0,43	90	14	173	0,29	90	
70	40	157	0,73	90	20	165	0,38	90	13	173	0,26	90	
80	35	157	0,64	90	18	165	0,34	90	11	173	0,23	90	
95,20	29	157	0,54	90	15	165	0,28	90	9	173	0,19	90	
108	26	157	0,47	90	13	165	0,25	90	8	173	0,17	90	
120	23	157	0,43	90	12	165	0,22	90	8	173	0,15	90	
142,8	19	157	0,35	90	10	165	0,19	90	6	173	0,13	90	

P_{tN} [kW]	tutti i rapporti all ratios alle Untersetzungen
	1.9

N.B. Per i riduttori evidenziati dal doppio bordo nella colonna delle potenze è necessario verificare lo scambio termico del riduttore ().

NOTE. Please pay attention to the frame around the input power value: for this gearboxes it's important to check the thermal capacity ().

HINWEIS. Sind in den Tabellen Nennleistungen eingerahmt, so ist die thermische Leistungsgrenze der Getriebe zu beachten ().

N.B. I pesi riportati sono indicativi e possono variare in funzione della versione del riduttore.

NOTE. Listed weights are for reference only and can vary according to the gearbox version.

HINWEIS. Die angegeben Gewichtsmaße sind Richtwerte und können je nach Getriebeversion variieren.



1.6 Prestazioni riduttori SM

1.6 SM gearboxes performances

1.6 Leistungen der SM-Getriebe

SM 45



10

ir	$n_1 = 2800 \text{ min}^{-1}$				$n_1 = 1400 \text{ min}^{-1}$				$n_1 = 900 \text{ min}^{-1}$				IEC
	n_2 min ⁻¹	T_{2M} Nm	P kW	RD %	n_2 min ⁻¹	T_{2M} Nm	P kW	RD %	n_2 min ⁻¹	T_{2M} Nm	P kW	RD %	
8	350	100	4,07	90	175	110	2,24	90	113	130	1,70	90	100-112 B14 90 B5 90 B14 80 B5 80 B14 71 B5 71 B14
10	280	120	3,91	90	140	145	2,36	90	90	160	1,68	90	
14	200	180	4,19	90	100	200	2,33	90	64	225	1,68	90	
16	175	195	3,97	90	88	230	2,34	90	56	250	1,64	90	
17.5	160	200	3,72	90	80	230	2,14	90	51	230	1,38	90	
20	140	215	3,50	90	70	250	2,04	90	45	260	1,36	90	
25	112	220	2,87	90	56	250	1,63	90	36	260	1,09	90	
28	100	220	2,56	90	50	250	1,45	90	32	250	0,93	90	
32	88	230	2,34	90	44	250	1,27	90	28	260	0,85	90	
35	80	220	2,05	90	40	250	1,16	90	26	245	0,73	90	
40	70	230	1,87	90	35	250	1,02	90	23	260	0,68	90	
50	56	220	1,43	90	28	250	0,81	90	18	260	0,54	90	
56	50	220	1,28	90	25	250	0,73	90	16	260	0,49	90	
62	45	210	1,10	90	23	245	0,64	90	15	245	0,41	90	
70	40	220	1,02	90	20	250	0,58	90	13	260	0,39	90	
86,8	32	220	0,83	90	16	245	0,46	90	10	245	0,30	90	
100	28	200	0,65	90	14	240	0,39	90	9	260	0,27	90	
124	23	200	0,53	90	11	240	0,32	90	7	260	0,22	90	
148,8	19	200	0,44	90	9	240	0,26	90	6	245	0,17	90	

Pt _N [kW]	tutti i rapporti all ratios alle Untersetzungen
	2.5

N.B. Per i riduttori evidenziati dal doppio bordo nella colonna delle potenze è necessario verificare lo scambio termico del riduttore ().

N.B. I pesi riportati sono indicativi e possono variare in funzione della versione del riduttore.

NOTE. Please pay attention to the frame around the input power value: for this gearboxes it's important to check the thermal capacity ().

NOTE. Listed weights are for reference only and can vary according to the gearbox version.

HINWEIS. Sind in den Tabellen Nennleistungen eingerahmt, so ist die thermische Leistungsgrenze der Getriebe zu beachten ().

HINWEIS. Die angegebenen Gewichtsmaße sind Richtwerte und können je nach Getriebeversion variieren.



1.7 Prestazioni motoriduttori

1.7 Gearmotors performances

1.7 Leistungen der Getriebemotoren

n_2 min ⁻¹	ir	T2 Nm	FS'	SM	
----------------------------	----	----------	-----	----	--

0.09 kW		$n_1 = 860 \text{ min}^{-1}$		63B 6	
----------------	--	------------------------------	--	-------	--

108	8.0	7.2	10.3	SM 25	63B 6
86	10.0	9.0	9.9	SM 25	63B 6
61	14.0	12.6	8.3	SM 25	63B 6
48	18.0	16.2	6.5	SM 25	63B 6
43	20.0	18.0	5.8	SM 25	63B 6
34	25.0	22	4.7	SM 25	63B 6
25	35.0	31	3.3	SM 25	63B 6
19.1	45.0	40	2.6	SM 25	63B 6
17.2	50.0	45	2.3	SM 25	63B 6
15.4	56.0	50	2.1	SM 25	63B 6
11.9	72.0	65	1.6	SM 25	63B 6
10.8	80.0	72	1.5	SM 25	63B 6
9.6	90.0	81	1.3	SM 25	63B 6
8.6	100.0	90	1.2	SM 25	63B 6

0.13 kW		$n_1 = 1360 \text{ min}^{-1}$ $n_1 = 860 \text{ min}^{-1}$		63A 4 63C 6	
----------------	--	---	--	----------------	--

170	8.0	6.6	10.7	SM 25	63A4
136	10.0	8.2	10.3	SM 25	63A4
97	14.0	11.5	8.7	SM 25	63A4
76	18.0	14.8	6.8	SM 25	63A4
68	20.0	16.4	6.1	SM 25	63A4
54	25.0	21	4.9	SM 25	63A4
48	18.0	23	4.5	SM 25	63C6
43	20.0	26	4.0	SM 25	63C6
39	35.0	29	3.5	SM 25	63A4
30	45.0	37	2.7	SM 25	63A4
27	50.0	41	2.4	SM 25	63A4
24	56.0	46	2.2	SM 25	63A4
18.9	72.0	59	1.7	SM 25	63A4
17.0	80.0	66	1.5	SM 25	63A4
15.1	90.0	74	1.4	SM 25	63A4
13.6	100.0	82	1.2	SM 25	63A4
11.9	72.0	94	1.1	SM 25	63C6
10.8	80.0	104	1.0	SM 25	63C6
9.6	90.0	117	0.90	SM 25	63C6
8.6	100.0	130	0.81	SM 25	63C6

n_2 min ⁻¹	ir	T2 Nm	FS'	SM	
----------------------------	----	----------	-----	----	--

0.18 kW		$n_1 = 1370 \text{ min}^{-1}$ $n_1 = 870 \text{ min}^{-1}$		63B 4 71A 6	
----------------	--	---	--	----------------	--

171	8.0	9.0	7.7	SM 25	63B4
137	10.0	11.3	7.5	SM 25	63B4
109	8.0	14.2	5.2	SM 25	71A6
98	14.0	15.8	6.3	SM 25	63B4
76	18.0	20	4.9	SM 25	63B4
69	20.0	23	4.4	SM 25	63B4
55	25.0	28	3.5	SM 25	63B4
48	18.0	32	3.3	SM 25	71A6
44	20.0	36	3.0	SM 25	71A6
39	35.0	40	2.5	SM 25	63B4
35	25.0	44	2.4	SM 25	71A6
30	45.0	51	2.0	SM 25	63B4
27	50.0	56	1.8	SM 25	63B4
24	56.0	63	1.6	SM 25	63B4
19.0	72.0	81	1.2	SM 25	63B4
17.1	80.0	90	1.1	SM 25	63B4
15.2	90.0	102	0.98	SM 25	63B4
13.7	100.0	113	0.89	SM 25	63B4
12.4	70.0	124	2.1	SM 45	71A6
12.4	70.0	124	1.4	SM 35	71A6
12.1	72.0	128	0.82	SM 25	71A6
10.9	80.0	142	1.2	SM 35	71A6
10.0	86.8	154	1.6	SM 45	71A6
9.1	95.2	169	1.0	SM 35	71A6
8.7	100.0	178	1.5	SM 45	71A6
8.1	108.0	192	0.90	SM 35	71A6
7.3	120.0	213	0.81	SM 35	71A6
7.0	124.0	221	1.2	SM 45	71A6
5.8	148.8	265	0.93	SM 45	71A6

0.22 kW		$n_1 = 1400 \text{ min}^{-1}$		63C 4	
----------------	--	-------------------------------	--	-------	--

175	8.0	10.8	6.5	SM 25	63C 4
140	10.0	13.5	6.3	SM 25	63C 4
100	14.0	18.9	5.3	SM 25	63C 4
78	18.0	24	4.1	SM 25	63C 4
70	20.0	27	3.7	SM 25	63C 4
56	25.0	34	3.0	SM 25	63C 4
40	35.0	47	2.1	SM 25	63C 4
31	45.0	61	1.6	SM 25	63C 4
28	50.0	68	1.5	SM 25	63C 4
25	56.0	76	1.3	SM 25	63C 4
19.4	72.0	97	1.0	SM 25	63C 4
17.5	80.0	108	0.93	SM 25	63C 4
15.6	90.0	122	0.82	SM 25	63C 4

n_2 min ⁻¹	ir	T2 Nm	FS'	SM	
----------------------------	----	----------	-----	----	--

0.25 kW		$n_1 = 1370 \text{ min}^{-1}$ $n_1 = 870 \text{ min}^{-1}$		71A 4 71B 6	
----------------	--	---	--	----------------	--

199	14.0	10.8	8.8	SM 25	63B2
171	8.0	12.5	5.6	SM 25	71A4
155	18.0	13.9	6.9	SM 25	63B2
140	20.0	15.4	6.2	SM 25	63B2
137	10.0	15.7	5.4	SM 25	71A4
112	25.0	19.3	4.9	SM 25	63B2
110	12.5	19.6	7.4	SM 35	71A4
98	14.0	22	4.6	SM 25	71A4
76	18.0	28	3.5	SM 25	71A4
69	20.0	31	3.2	SM 25	71A4
62	14.0	35	3.0	SM 25	71B6
55	25.0	39	2.6	SM 25	71A4
50	56.0	43	2.2	SM 25	63B2
46	29.8	47	3.6	SM 35	71A4
39	35.0	55	3.2	SM 35	71A4
39	35.0	55	1.8	SM 25	71A4
34	40.0	63	4.0	SM 45	71A4
30	45.0	71	2.3	SM 35	71A4
30	45.0	71	1.4	SM 25	71A4
27	50.0	78	3.2	SM 45	71A4
27	50.0	78	2.1	SM 35	71A4
27	50.0	78	1.3	SM 25	71A4
24	56.0	88	2.8	SM 45	71A4
24	56.0	88	1.9	SM 35	71A4
24	56.0	88	1.1	SM 25	71A4
22	62.0	97	2.5	SM 45	71A4
22	63.0	99	1.7	SM 35	71A4
19.6	70.0	110	2.3	SM 45	71A4
19.6	70.0	110	1.5	SM 35	71A4
19.0	72.0	113	0.89	SM 25	71A4
17.1	80.0	125	1.3	SM 35	71A4
17.1	80.0	125	0.80	SM 25	71A4
15.8	86.8	136	1.8	SM 45	71A4
14.4	95.2	149	1.1	SM 35	71A4
13.7	100.0	157	1.5	SM 45	71A4
12.7	108.0	169	0.97	SM 35	71A4
11.4	120.0	188	0.88	SM 35	71A4
11.0	124.0	194	1.2	SM 45	71A4
9.2	148.8	233	1.0	SM 45	71A4
8.7	100.0	247	1.1	SM 45	71B6
7.0	124.0	306	0.85	SM 45	71B6



1.7 Prestazioni motoriduttori

1.7 Gearmotors performances

1.7 Leistungen der Getriebemotoren

n ₂ min ⁻¹	ir	T ₂ Nm	FS'	SM	
-------------------------------------	----	----------------------	-----	----	--

0.37 kW		n ₁ = 2790 min ⁻¹ n ₁ = 1380 min ⁻¹ n ₁ = 910 min ⁻¹		63C 2 71B 4 80A 6
----------------	--	--	--	-------------------------

279	10.0	11.4	7.1	SM 25	63C2
199	14.0	16.0	6.0	SM 25	63C2
173	8.0	18.4	3.8	SM 25	71B4
155	18.0	21	4.6	SM 25	63C2
138	10.0	23	3.7	SM 25	71B4
112	25.0	28	3.3	SM 25	63C2
110	12.5	29	5.0	SM 35	71B4
99	14.0	32	3.1	SM 25	71B4
91	10.0	35	2.5	SM 25	80A6
77	18.0	41	3.5	SM 35	71B4
77	18.0	41	2.4	SM 25	71B4
69	20.0	46	3.1	SM 35	71B4
69	20.0	46	2.2	SM 25	71B4
55	25.0	58	3.0	SM 35	71B4
55	25.0	58	1.7	SM 25	71B4
46	29.8	69	2.5	SM 35	71B4
43	32.0	74	3.4	SM 45	71B4
39	35.0	81	3.1	SM 45	71B4
39	35.0	81	2.2	SM 35	71B4
39	35.0	81	1.2	SM 25	71B4
35	40.0	92	2.7	SM 45	71B4
31	45.0	104	1.6	SM 35	71B4
31	45.0	104	0.96	SM 25	71B4
28	50.0	115	2.2	SM 45	71B4
28	50.0	115	1.4	SM 35	71B4
28	50.0	115	0.87	SM 25	71B4
25	56.0	129	1.9	SM 45	71B4
25	56.0	129	1.3	SM 35	71B4
22	62.0	143	1.7	SM 45	71B4
22	63.0	145	1.1	SM 35	71B4
19.7	70.0	161	1.5	SM 45	71B4
19.7	70.0	161	1.0	SM 35	71B4
17.3	80.0	184	0.90	SM 35	71B4
15.9	86.8	200	1.2	SM 45	71B4
13.8	100.0	230	1.0	SM 45	71B4
11.1	124.0	286	0.84	SM 45	71B4

0.55 kW		n ₁ = 2800 min ⁻¹ n ₁ = 1390 min ⁻¹ n ₁ = 1380 min ⁻¹		71B 2 80A 4 71C 4
----------------	--	---	--	-------------------------

350	8.0	13.5	5.0	SM 25	71B2
280	10.0	16.9	4.8	SM 25	71B2
200	14.0	24	4.0	SM 25	71B2
174	8.0	27	3.3	SM 35	80A4
174	8.0	27	2.6	SM 25	80A4
173	8.0	27	3.3	SM 35	71C4

n ₂ min ⁻¹	ir	T ₂ Nm	FS'	SM	
-------------------------------------	----	----------------------	-----	----	--

0.55 kW		n ₁ = 2800 min ⁻¹ n ₁ = 1390 min ⁻¹ n ₁ = 1380 min ⁻¹		71B 2 80A 4 71C 4
----------------	--	---	--	-------------------------

173	8.0	27	2.6	SM 25	71C4
156	18.0	30	3.1	SM 25	71B2
139	10.0	34	3.4	SM 35	80A4
139	10.0	34	2.5	SM 25	80A4
138	10.0	34	3.4	SM 35	71C4
138	10.0	34	2.5	SM 25	71C4
111	12.5	43	3.4	SM 35	80A4
110	12.5	43	3.4	SM 35	71C4
99	14.0	48	3.0	SM 35	80A4
99	14.0	48	2.1	SM 25	80A4
99	14.0	48	3.0	SM 35	71C4
99	14.0	48	2.1	SM 25	71C4
87	16.0	54	4.2	SM 45	80A4
86	16.0	55	4.2	SM 45	71C4
77	18.0	61	2.4	SM 35	80A4
77	18.0	61	1.6	SM 25	80A4
77	18.0	62	2.4	SM 35	71C4
77	18.0	62	1.6	SM 25	71C4
70	20.0	68	2.1	SM 35	80A4
70	20.0	68	1.5	SM 25	80A4
69	20.0	69	2.1	SM 35	71C4
69	20.0	69	1.5	SM 25	71C4
56	25.0	85	2.9	SM 45	80A4
56	25.0	85	2.1	SM 35	80A4
56	25.0	85	1.2	SM 25	80A4
55	25.0	86	2.9	SM 45	71C4
55	25.0	86	2.0	SM 35	71C4
55	25.0	86	1.2	SM 25	71C4
50	28.0	95	2.6	SM 45	80A4
49	28.0	96	2.6	SM 45	71C4
47	29.8	101	1.7	SM 35	80A4
46	29.8	102	1.7	SM 35	71C4
43	32.0	109	2.3	SM 45	80A4
43	32.0	110	2.3	SM 45	71C4
40	35.0	119	2.1	SM 45	80A4
40	35.0	119	1.5	SM 35	80A4
40	35.0	119	0.84	SM 25	80A4
39	35.0	120	2.1	SM 45	71C4
39	35.0	120	1.5	SM 35	71C4
39	35.0	120	0.83	SM 25	71C4
35	40.0	136	1.8	SM 45	80A4
35	40.0	137	1.8	SM 45	71C4
31	45.0	153	1.1	SM 35	80A4
31	45.0	154	1.1	SM 35	71C4
28	50.0	170	1.5	SM 45	80A4
28	50.0	170	0.97	SM 35	80A4
28	50.0	171	1.5	SM 45	71C4
28	50.0	171	0.96	SM 35	71C4

n ₂ min ⁻¹	ir	T ₂ Nm	FS'	SM	
-------------------------------------	----	----------------------	-----	----	--

0.55 kW		n ₁ = 2800 min ⁻¹ n ₁ = 1390 min ⁻¹ n ₁ = 1380 min ⁻¹		71B 2 80A 4 71C 4
----------------	--	---	--	-------------------------

25	56.0	190	1.3	SM 45	80A4
25	56.0	190	0.87	SM 35	80A4
25	56.0	192	1.3	SM 45	71C4
25	56.0	192	0.86	SM 35	71C4
22	62.0	211	1.2	SM 45	80A4
22	62.0	212	1.2	SM 45	71C4
19.9	70.0	238	1.1	SM 45	80A4
19.7	70.0	240	1.0	SM 45	71C4
16.0	86.8	295	0.83	SM 45	80A4
15.9	86.8	297	0.82	SM 45	71C4

0.75 kW		n ₁ = 2800 min ⁻¹ n ₁ = 1390 min ⁻¹		71C 2 80B 4
----------------	--	--	--	----------------

350	8.0	18.4	3.6	SM 25	71C2
280	10.0	23	3.5	SM 25	71C2
200	14.0	32	2.9	SM 25	71C2
174	8.0	37	3.0	SM 45	80B4
174	8.0	37	2.4	SM 35	80B4
174	8.0	37	1.9	SM 25	80B4
139	10.0	46	3.1	SM 45	80B4
139	10.0	46	2.5	SM 35	80B4
139	10.0	46	1.8	SM 25	80B4
111	12.5	58	2.5	SM 35	80B4
99	14.0	65	3.1	SM 45	80B4
99	14.0	65	2.2	SM 35	80B4
99	14.0	65	1.5	SM 25	80B4
87	16.0	74	3.1	SM 45	80B4
77	18.0	83	2.8	SM 45	80B4
77	18.0	83	1.7	SM 35	80B4
77	18.0	83	1.2	SM 25	80B4
70	20.0	93	2.7	SM 45	80B4
70	20.0	93	1.6	SM 35	80B4
70	20.0	93	1.1	SM 25	80B4
56	25.0	116	2.2	SM 45	80B4
56	25.0	116	1.5	SM 35	80B4
56	25.0	116	0.86	SM 25	80B4
50	28.0	130	1.9	SM 45	80B4
47	29.8	138	1.2	SM 35	80B4
43	32.0	148	1.7	SM 45	80B4
40	35.0	162	1.5	SM 45	80B4
40	35.0	162	1.1	SM 35	80B4
35	40.0	186	1.3	SM 45	80B4
28	50.0	232	1.1	SM 45	80B4
25	56.0	260	0.96	SM 45	80B4
22	62.0	288	0.85	SM 45	80B4



1.7 Prestazioni motoriduttori

1.7 Gearmotors performances

1.7 Leistungen der Getriebemotoren

n_2 min ⁻¹	ir	T2 Nm	FS'	SM	
----------------------------	----	----------	-----	----	---

0.88 kW		$n_1 = 1350 \text{ min}^{-1}$		80C 4	
----------------	--	-------------------------------	--	-------	--

169	8.0	45	2.5	SM 45	80C4
169	8.0	45	2.0	SM 35	80C4
169	8.0	45	1.6	SM 25	80C4
135	10.0	56	2.6	SM 45	80C4
135	10.0	56	2.1	SM 35	80C4
135	10.0	56	1.5	SM 25	80C4
108	12.5	70	2.1	SM 35	80C4
96	14.0	78	2.5	SM 45	80C4
96	14.0	78	1.8	SM 35	80C4
96	14.0	78	1.3	SM 25	80C4
84	16.0	90	2.6	SM 45	80C4
75	18.0	101	2.3	SM 45	80C4
75	18.0	101	1.4	SM 35	80C4
75	18.0	101	0.99	SM 25	80C4
68	20.0	112	2.2	SM 45	80C4
68	20.0	112	1.3	SM 35	80C4
68	20.0	112	0.89	SM 25	80C4
54	25.0	140	1.8	SM 45	80C4
54	25.0	140	1.2	SM 35	80C4
48	28.0	157	1.6	SM 45	80C4
45	29.8	167	1.0	SM 35	80C4
42	32.0	179	1.4	SM 45	80C4
39	35.0	196	1.3	SM 45	80C4
39	35.0	196	0.89	SM 35	80C4
34	40.0	224	1.1	SM 45	80C4
27	50.0	280	0.89	SM 45	80C4
24	56.0	314	0.80	SM 45	80C4

1.1 kW		$n_1 = 2830 \text{ min}^{-1}$ $n_1 = 1390 \text{ min}^{-1}$		80B 2 80D 4	
---------------	--	--	--	----------------	--

354	8.0	27	3.2	SM 35	80B2
354	8.0	27	2.5	SM 25	80B2
283	10.0	33	3.3	SM 35	80B2
283	10.0	33	2.4	SM 25	80B2
226	12.5	42	3.3	SM 35	80B2
202	14.0	47	3.0	SM 35	80B2
202	14.0	47	2.0	SM 25	80B2
174	8.0	54	2.0	SM 45	80D4
174	8.0	54	1.7	SM 35	80D4
174	8.0	54	1.3	SM 25	80D4
139	10.0	68	2.1	SM 45	80D4
139	10.0	68	1.7	SM 35	80D4
139	10.0	68	1.2	SM 25	80D4
111	12.5	85	1.7	SM 35	80D4

n_2 min ⁻¹	ir	T2 Nm	FS'	SM	
----------------------------	----	----------	-----	----	--

1.1 kW		$n_1 = 2830 \text{ min}^{-1}$ $n_1 = 1390 \text{ min}^{-1}$		80B 2 80D 4	
---------------	--	--	--	----------------	--

99	14.0	95	2.1	SM 45	80D4
99	14.0	95	1.5	SM 35	80D4
99	14.0	95	1.1	SM 25	80D4
87	16.0	109	2.1	SM 45	80D4
77	18.0	122	1.9	SM 45	80D4
77	18.0	122	1.2	SM 35	80D4
77	18.0	122	0.82	SM 25	80D4
70	20.0	136	1.8	SM 45	80D4
70	20.0	136	1.1	SM 35	80D4
56	25.0	170	1.5	SM 45	80D4
56	25.0	170	1.0	SM 35	80D4
50	28.0	190	1.3	SM 45	80D4
47	29.8	202	0.84	SM 35	80D4
43	32.0	218	1.1	SM 45	80D4
40	35.0	238	1.1	SM 45	80D4
35	40.0	272	0.92	SM 45	80D4

1.5 kW		$n_1 = 2830 \text{ min}^{-1}$ $n_1 = 1400 \text{ min}^{-1}$		80C 2 90L 4	
---------------	--	--	--	----------------	--

354	8.0	36	2.7	SM 45	80C2
354	8.0	36	2.4	SM 35	80C2
354	8.0	36	1.8	SM 25	80C2
283	10.0	46	2.6	SM 45	80C2
283	10.0	46	2.4	SM 35	80C2
283	10.0	46	1.8	SM 25	80C2
226	12.5	57	2.4	SM 35	80C2
202	14.0	64	2.8	SM 45	80C2
202	14.0	64	2.2	SM 35	80C2
202	14.0	64	1.5	SM 25	80C2
175	8.0	74	1.5	SM 45	90L4
175	8.0	74	1.2	SM 35	90L4
175	8.0	74	0.95	SM 25	90L4
140	10.0	92	1.6	SM 45	90L4
140	10.0	92	1.2	SM 35	90L4
140	10.0	92	0.92	SM 25	90L4
112	12.5	115	1.3	SM 35	90L4
100	14.0	129	1.6	SM 45	90L4
100	14.0	129	1.1	SM 35	90L4
88	16.0	147	1.6	SM 45	90L4
78	18.0	166	1.4	SM 45	90L4
78	18.0	166	0.87	SM 35	90L4
70	20.0	184	1.4	SM 45	90L4
56	25.0	230	1.1	SM 45	90L4

n_2 min ⁻¹	ir	T2 Nm	FS'	SM	
----------------------------	----	----------	-----	----	---

1.5 kW		$n_1 = 2830 \text{ min}^{-1}$ $n_1 = 1400 \text{ min}^{-1}$		80C 2 90L 4	
---------------	--	--	--	----------------	--

50	28.0	258	0.97	SM 45	90L4
44	32.0	295	0.85	SM 45	90L4

1.8 kW		$n_1 = 2770 \text{ min}^{-1}$ $n_1 = 1400 \text{ min}^{-1}$		80D 2 90LB 4	
---------------	--	--	--	-----------------	--

346	8.0	45	2.2	SM 45	80D2
346	8.0	45	1.9	SM 35	80D2
346	8.0	45	1.5	SM 25	80D2
277	10.0	56	2.1	SM 45	80D2
277	10.0	56	2.0	SM 35	80D2
277	10.0	56	1.5	SM 25	80D2
222	12.5	70	2.0	SM 35	80D2
198	14.0	78	2.3	SM 45	80D2
198	14.0	78	1.8	SM 35	80D2
198	14.0	78	1.2	SM 25	80D2
175	8.0	88	1.2	SM 45	90LB4
175	8.0	88	1.0	SM 35	90LB4
154	18.0	101	2.0	SM 45	80D2
154	18.0	101	1.4	SM 35	80D2
154	18.0	101	0.94	SM 25	80D2
140	10.0	111	1.3	SM 45	90LB4
140	10.0	111	1.0	SM 35	90LB4
112	12.5	138	1.0	SM 35	90LB4
100	14.0	155	1.3	SM 45	90LB4
100	14.0	155	0.94	SM 35	90LB4
88	16.0	177	1.3	SM 45	90LB4
78	18.0	199	1.2	SM 45	90LB4
70	20.0	221	1.1	SM 45	90LB4
56	25.0	276	0.90	SM 45	90LB4
50	28.0	309	0.81	SM 45	90LB4



1.7 Prestazioni motoriduttori

n_2 min ⁻¹	ir	T2 Nm	FS'	SM	
----------------------------	----	----------	-----	----	--

2.2 kW	$n_1 = 2840 \text{ min}^{-1}$	90L 2
	$n_1 = 1410 \text{ min}^{-1}$	100A 4
	$n_1 = 940 \text{ min}^{-1}$	100LB 6

355	8.0	53	1.9	SM 45	90L2
355	8.0	53	1.6	SM 35	90L2
355	8.0	53	1.3	SM 25	90L2
284	10.0	67	1.8	SM 45	90L2
284	10.0	67	1.6	SM 35	90L2
284	10.0	67	1.2	SM 25	90L2
227	12.5	83	1.7	SM 35	90L2
203	14.0	93	1.9	SM 45	90L2
203	14.0	93	1.5	SM 35	90L2
203	14.0	93	1.0	SM 25	90L2
176	8.0	107	1.0	SM 45	100A4
142	20.0	133	1.0	SM 35	90L2
141	10.0	134	1.1	SM 45	100A4
101	14.0	188	1.1	SM 45	100A4
95	29.8	198	0.82	SM 35	90L2
88	16.0	215	1.1	SM 45	100A4
78	18.0	241	0.95	SM 45	100A4
71	20.0	268	0.93	SM 45	100A4
67	14.0	282	0.80	SM 45	100BL6

1.7 Gearmotors performances

n_2 min ⁻¹	ir	T2 Nm	FS'	SM	
----------------------------	----	----------	-----	----	--

3 kW	$n_1 = 2840 \text{ min}^{-1}$	90LB 2
	$n_1 = 1420 \text{ min}^{-1}$	100LB 4

355	8.0	73	1.4	SM 45	90LB2
355	8.0	73	1.2	SM 35	90LB2
355	8.0	73	0.92	SM 25	90LB2
284	10.0	91	1.3	SM 45	90LB2
284	10.0	91	1.2	SM 35	90LB2
284	10.0	91	0.89	SM 25	90LB2
227	12.5	113	1.2	SM 35	90LB2
203	14.0	127	1.4	SM 45	90LB2
203	14.0	127	1.1	SM 35	90LB2
178	16.0	145	1.3	SM 45	90LB2
158	18.0	163	1.2	SM 45	90LB2
158	18.0	163	0.84	SM 35	90LB2
142	20.0	182	1.2	SM 45	90LB2
142	10.0	182	0.80	SM 45	100B4
114	25.0	227	0.97	SM 45	90LB2
101	28.0	254	0.87	SM 45	90LB2

1.7 Leistungen der Getriebemotoren

n_2 min ⁻¹	ir	T2 Nm	FS'	SM	
----------------------------	----	----------	-----	----	--

4 kW	$n_1 = 2860 \text{ min}^{-1}$	100B 2
-------------	-------------------------------	--------

358	8.0	96	1.0	SM 45	100B2
286	10.0	120	1.0	SM 45	100B2
204	14.0	168	1.1	SM 45	100B2
179	16.0	192	1.0	SM 45	100B2
159	18.0	216	0.92	SM 45	100B2
143	20.0	240	0.89	SM 45	100B2





1.8 Dimensioni

1.8 Dimensions

1.8 Abmessungen

SM 25 - 35 - 45

SM 25 - 35 - 45...F1...

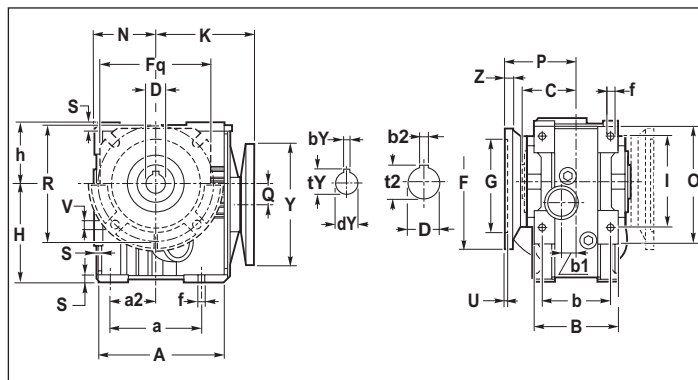
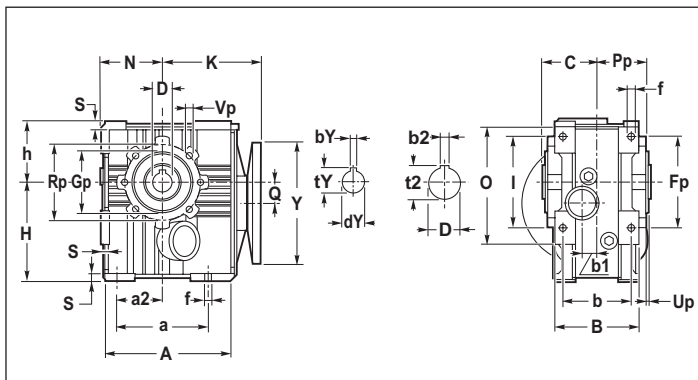

Tab. 2.8.1

SM	A	a	a2	B	b	b1	C	D	f	h	H	I	N	O	Q	S	K
25	122	90	45	90	73.5	16,55	52.5	19 (20*) (24*)	9	65	107	90	65	122	25.5	8	100 ⁽¹⁾
35	130	100	50	95	75	17.5	60	25 (28*) (30*)	9	70	123.5	100	70	130	28.5	8	122.5
45	165	120	60	110	90	19	70	30 (25*) (28*)	9	80	130	120	80	155	27.5	10	129.5 ⁽²⁾

⁽¹⁾ Per il PAM 90 B5 e B14 contattare Ufficio Commerciale
⁽¹⁾ For PAM 90 B5 and B14, please contact Sales Department
⁽¹⁾ Für PAM 90 B5 und B14 wenden Sie sich bitte an unsere Handelsabteilung

⁽²⁾ Per il PAM 100-112 B14 contattare Ufficio Commerciale
⁽²⁾ For PAM 100-112 B14, please contact Sales Department
⁽²⁾ Für PAM 100-112 B14 wenden Sie sich bitte an unsere Handelsabteilung

* A richiesta / Upon Request / Auf Anfrage

Tab. 2.8.2

SM	25	35	45
Fp	100	110	120
Gp	70	80	80
Pp	50	55.5	65
Rp	85	95	100
Up	2.5	2.5	3
Vp	M8	M8	M8

Tab. 2.8.3

SM	F	Fq	G (g6)	P	R	U	V	Z
25	F1	175	-	115	78.5	5	11	11
	F2	200	-	130	94.5		13	
	F3	160	-	110	74.5		10	
	FL	180	-	115	108.5		11	
	* FA	125	110	70	96.5		8.5	9
35	FA	180	142	115	84.5	6	11	10
	FB			114.5				
45	F1	175	-	115	124	5	11	10
	F2	175	-	115	93			
	FL	200	-	130	119			165

* A richiesta / Upon Request / Auf Anfrage



ESTREMITÀ USCITA - Accessori - Opzioni
OUTPUT CONFIGURATIONS - Accessories - Options
ENDEN DER AUSGANGSWELLEN - Zubehör - Optionen

	<p>Output shaft Double integral output shaft D16</p>
	<p>Hollow shaft with keyway D17</p>
	<p>Hollow shaft with shrink disk D18</p>

AL	BRS	BRS VKL	PROT

OPT - ACC. -
Accessories - Options D19

STM
team

STM
team

D

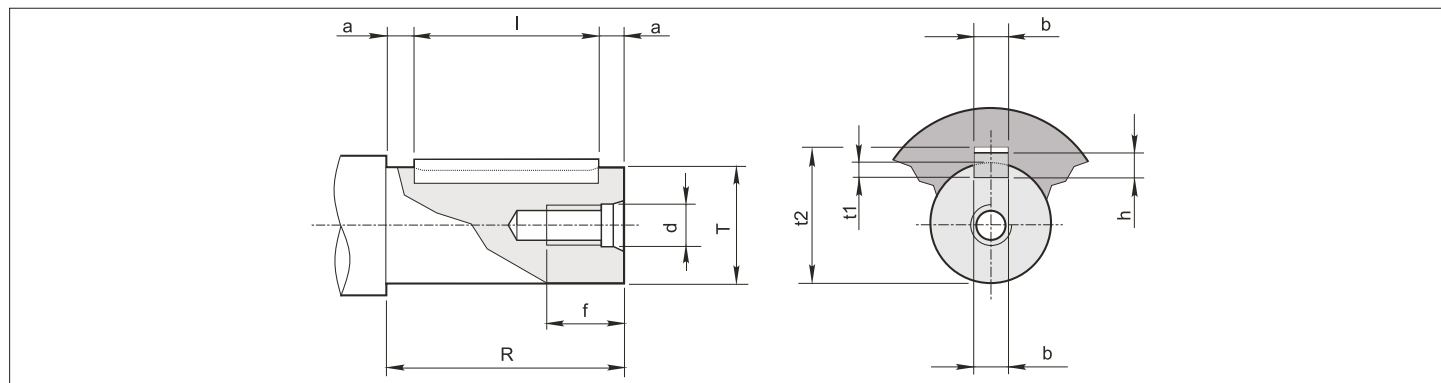
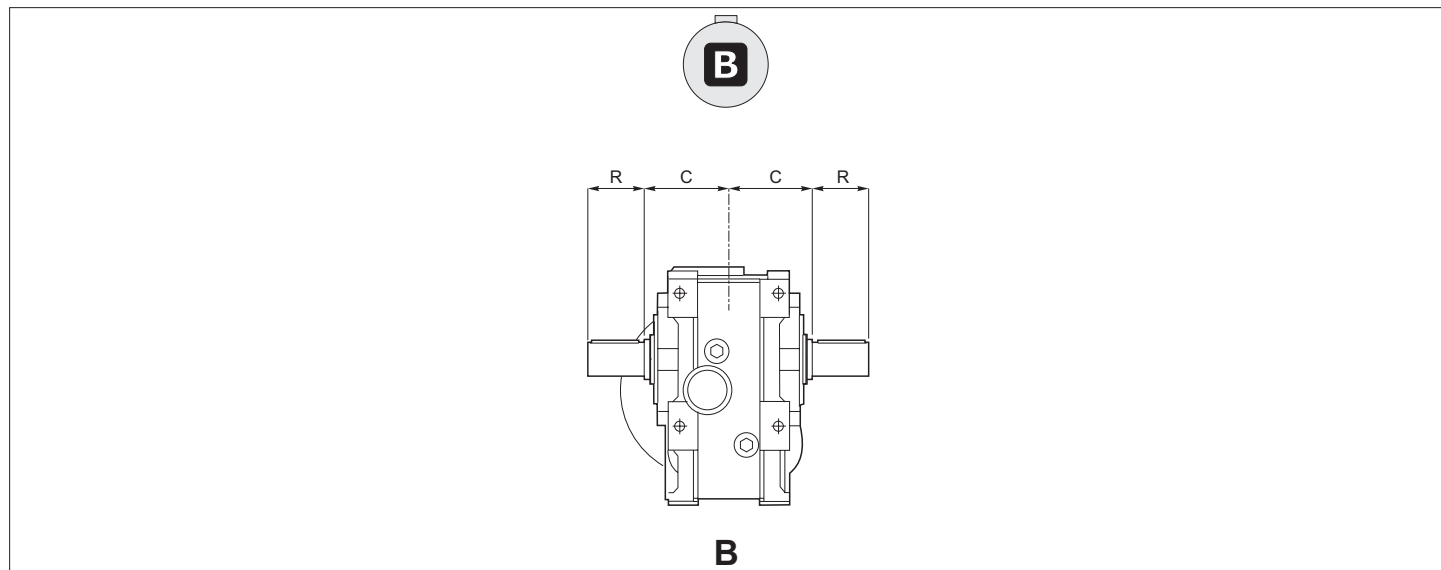

	Ø Albero Ø Shaft Ø Welle		Foro fil. testa Tapped hole Gewindebohrung Kopfi		Cava Keyway Nut			Estremità d'albero Shaft end Wellenende		Linguetta Key Federkeil
	T	C	d	f	b	t1	t2	R	a	bxhxl
25	19 g6	52.5	M 6	15	6	3.5	21.8	40	8	6X7X25
35	25 g6	60	M 8	22	8	4	28.3	60	10	8X7X40
45	30 g6	70	M 10	25	8	4	33.3	60	5	8X7X50

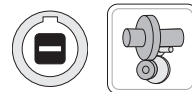

1.8.1 - ALBERI LENTI

1.8.1 - OUTPUT SHAFT

1.8.1 - ABTRIEBSWELLEN

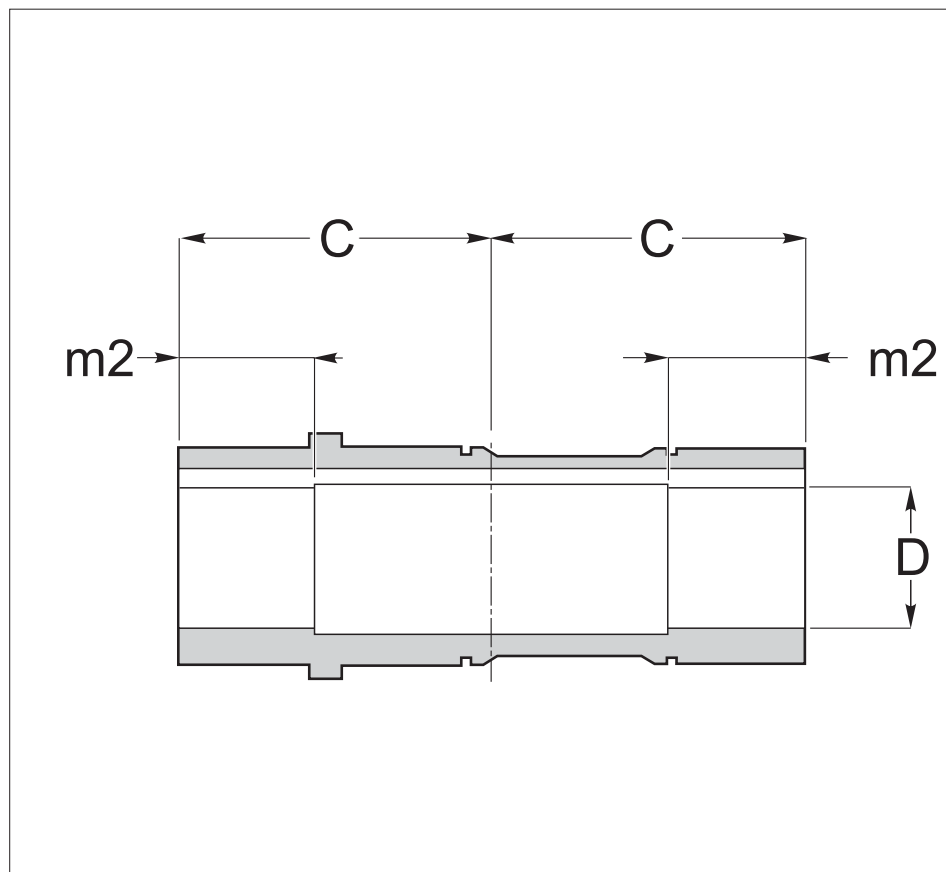
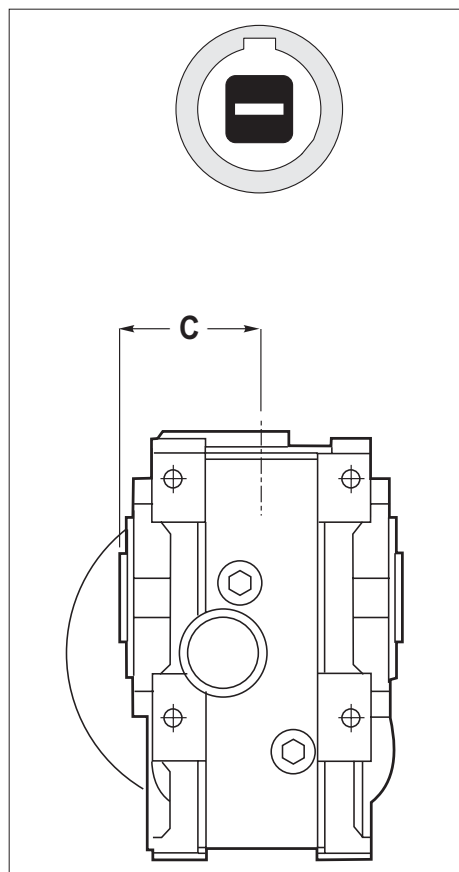

	25	35	45
C	52.5	60	70
D H7	19 (24) (20)	25 (30) (28)	30 (28) (25)
m2	25.5	25.5	30.5

Perno macchina / Customer shaft / Maschinachse

	d1 g6	m3	Lm	m	H	L min	P	R	Ra	Rb
25	19 (24) (20)	30	15 (25) (15)	M 6 (M 8) (M 6)	103	40	18.8 (23.8) (19.8)	30		
35	25 (30) (28)	30	25 (25) (25)	M 8 (M 10) (M 10)	118	60	24.8 (29.8) (27.8)	40		
45	30 (28) (25)	35	25 (25) (25)	M 10 (M 10) (M 8)	138	60	29.8 (27.8) (24.8)	40		

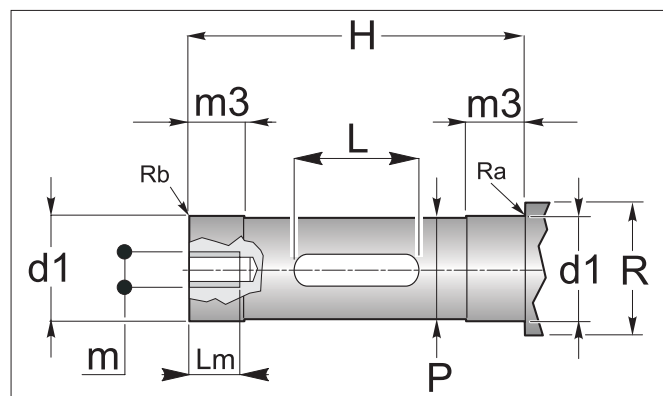



1.8.1 - ALBERI LENTI

1.8.1 - OUTPUT SHAFT

1.8.1 - ABTRIEBSWELLEN

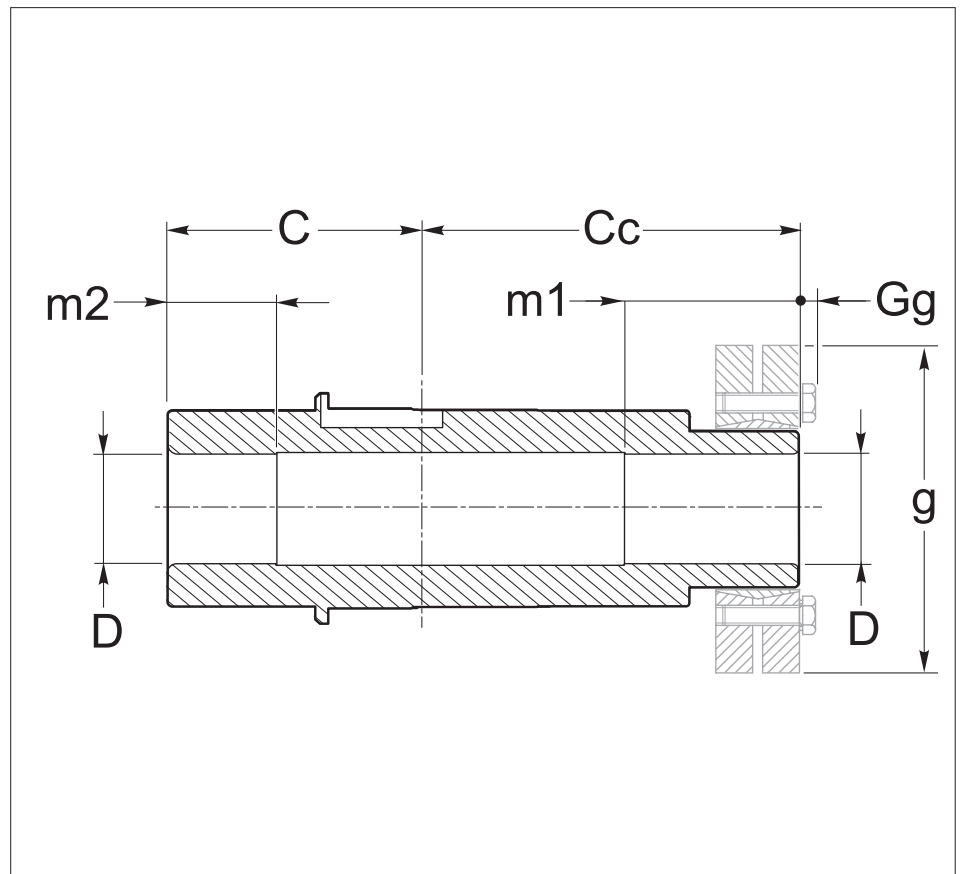
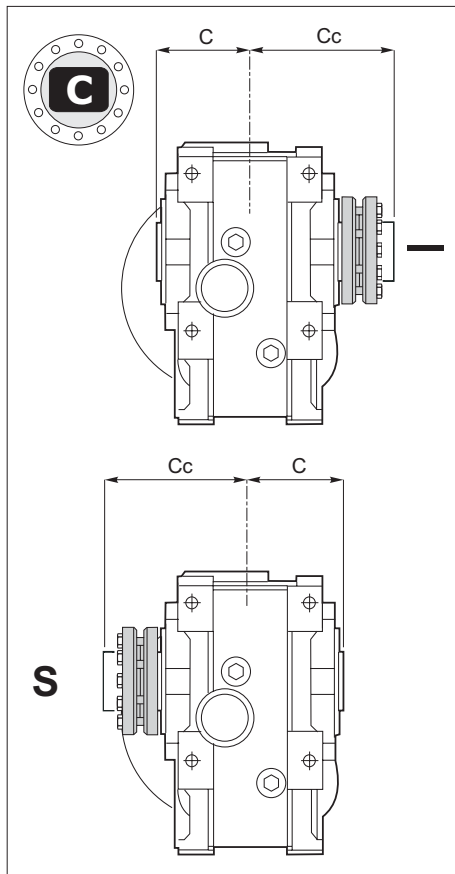

	25	35	45
C	52.5	60	70
Cc	74.5	85	95
D H7	19	25	30
m1	35	40	45
m2	25.5	25.5	20
g	50	60	72
Gg	3.5	3.5	4

Perno macchina / Customer shaft / Maschinachse

	d1 h6	H	m3	m4	P	R	Ra	Rb
25	19	127	40	30	18.8	30		
35	25	145	45	30	24.8	40		
45	30	*	*	35	34.8	43		

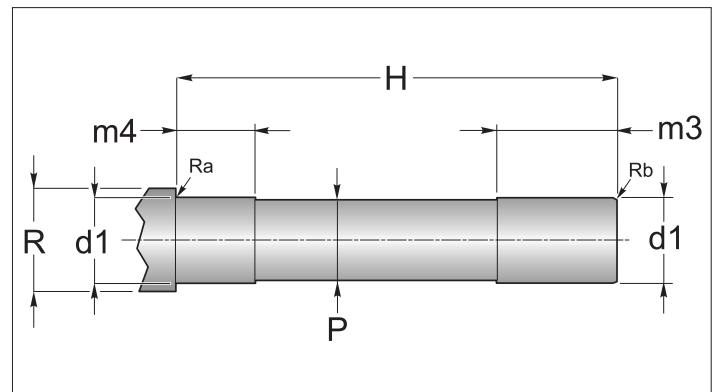

*Contattare il ns. servizio tecnico / Contact our technical dept / Wenden Sie sich an unseren technischen Service



AL AL - ALBERO LENTO SPORGENTE

AL - SINGLE OUTPUT SHAFTS

AL - EINSEITIGE ABTRIEBSWELLEN

Tutti i riduttori sono forniti con albero lento cavo. A richiesta, possono essere forniti kit di montaggio per alberi sporgenti comprensivi di linguette, rondelle e viti di fissaggio. Le dimensioni delle linguette sono conformi alle norme UNI 6604-69.

All gearboxes are supplied with hollow output shaft. On request there are available also assembly kits including output shafts, keys, washers and assembly screws. The dimensions of the keys are conform with UNI 6604-69.

Alle Getriebe werden mit Abtriebshohlwelle geliefert. Auf Anfrage sind auch Montagekits inklusive Abtriebswellen, Paßfedern, Unterlegscheiben und Montageschrauben erhältlich. Die Abmessungen der Paßfedern sind konform mit der UNI 6604-69.

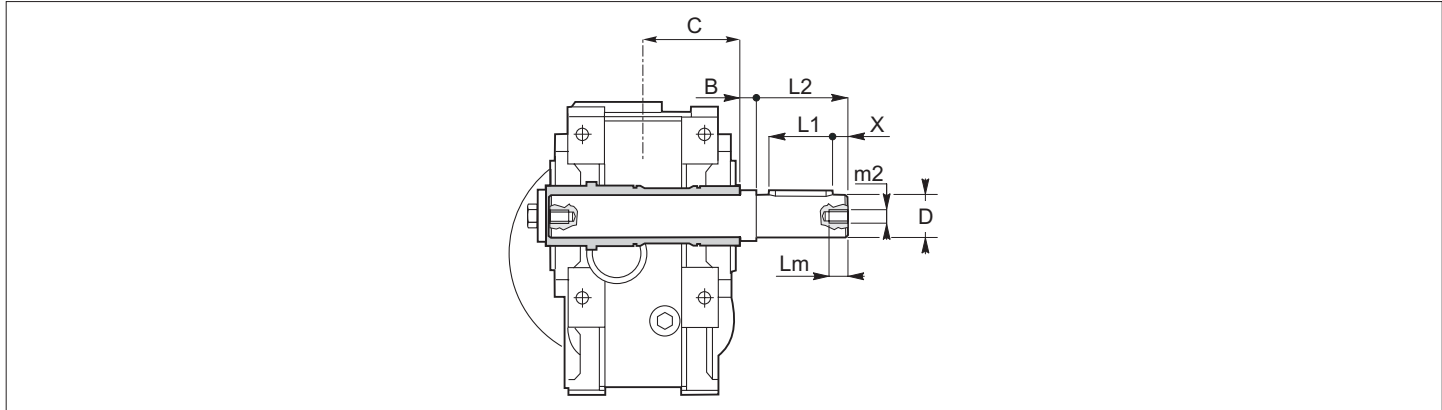

	B	C	D g6	m ₂	L ₁	L ₂	L _m	X
25*	10	52.5	19	M 8	25	40	16	8
35*	10	60	25	M 8	40	60	20	10
45*	3	70	30	M 10	50	60	25	5

* ATTENZIONE
L'albero lento sporgente è fornito per essere installato sulla versione del riduttore con albero **CAVO** con diametro **STANDARD**.

*ATTENTION
The output shaft is available only for standard hollow shaft diameter.

Achtung:
Die Einseitige Abtriebswelle wird fuer die Montage bei Getrieben mit Standart Hohlwelle geliefert.

BRS
BRS_VKL BRS_VKL BRACCIO REAZIONE

BRS
BRS_VKL TORQUE ARM

BRS
BRS_VKL DREHMOMENTSTÜTZE

Per il fissaggio del riduttore mediante tirante, viene fornito in allegato l'apposito braccio di reazione.

If the gearbox shall be shaft mounted as an extra part there is also available a torque arm.

Soll das Getriebe pendelnd gelagert werden, so ist als Zubehörteil auch eine Drehmomentstütze.

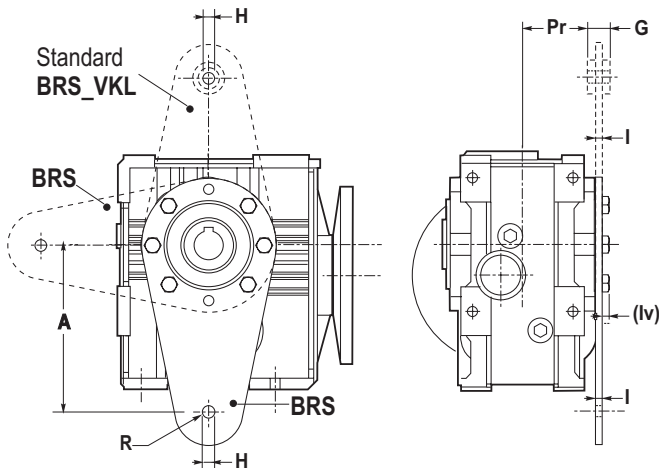

	A	G	H	I	Iv	Pr	R
25	100	15	10	4	5	44.5	25
35*	150	15	10	6	5	51.0	25
45	150	20	10	6	5	58	30

* Solo Con Boccola in VKL / With VKL bushing



PROT

PROT. - Coperchio di protezione

PROT. - Protection cover

PROT - Schutzvorrichtungdeckel

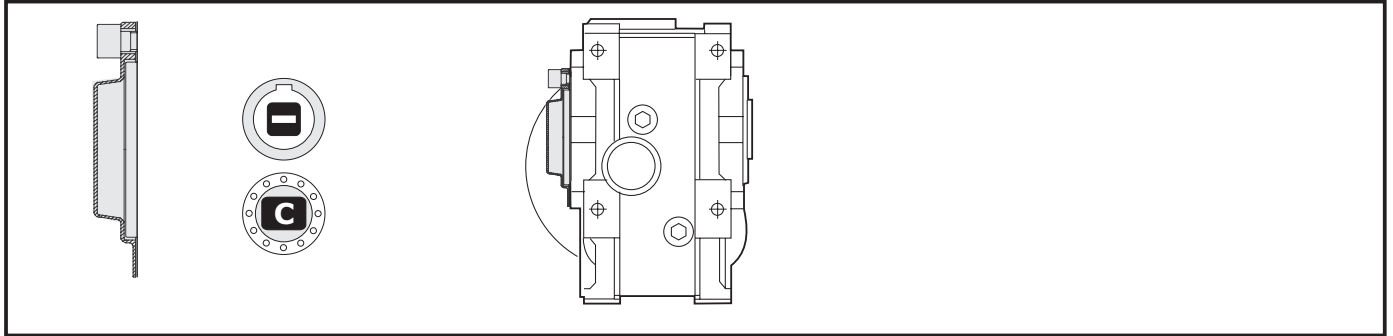

1.10 Linguette

1.10 Keys

1.10 Paßfedern

Albero Entrata - Input Shaft - Antriebswelle

SR		
d	b ₁	t ₁
9	3	10.2
11	4	12.5
14	5	16.0
16	5	18.0
18	6	20.5
19	6	21.5
24	8	27.0
25	8	28.0
28	8	31.0
30	8	33.0
32	10	35.0
35	10	38.0
38	10	41.0
42	12	45.0
45	14	48.5
48	14	51.5
50	14	53.5
55	16	59.0
65	18	69.0

SM PAM B5				
PAM B5	Y	dY	bY	tY
56	120	9	3	10.4
63	140	11	4	12.8
71	160	14	5	16.3
80	200	19	6	21.8
90	200	24	8	27.3
100	250	28	8	31.3
112	250	28	8	31.3
132	300	38	10	41.3
160	350	42	12	45.3
180	350	48	14	51.8
200	400	55	16	59.3

SM PAM B14				
PAM B14	Y	dY	bY	tY
56	80	9	3	10.4
63	90	11	4	12.8
71	105	14	5	16.3
80	120	19	6	21.8
90	140	24	8	27.3
100	160	28	8	31.3
112	160	28	8	31.3
132	200	38	10	41.3

Albero Uscita - Output Shaft - Abtriebswelle

Albero Forato / shaft with keyway Hohlwelle mit Paßfedernut S - SR - SM		
D	b ₂	t ₂
14	5	16.3
18	6	20.8
19	6	21.8
24	8	27.3
25	8	28.3
28	8	31.3
30	8	33.3
32	10	35.3
35	10	38.3
42	12	45.3
45	14	48.8
48	14	51.8
50	14	53.8
55	16	59.3
65	18	69.4

Albero Pieno / Solid shaft / Vollwelle S - SR - SM		
d ₂	b ₂	t ₂
9	3	10.2
11	4	12.5
14	5	16.0
16	5	18.0
18	6	20.5
19	6	21.5
24	8	27.0
25	8	28.0
28	8	31.0
30	8	33.0
32	10	35.0
35	10	38.0
38	10	41.0
42	12	45.0
45	14	48.5
48	14	51.5
50	14	53.5
55	16	59.0
65	18	69.0