







U

ACC. - OPT - ACCESSORI E OPZIONI
ACC. - OPT - ACCESSORIES AND OPTIONS
ACC. - OPT - ZUBEHÖR UND OPTIONEN

ACC4-R		ACC4	ACC4 - Accessori Vaso Espansione	ACC4 - Accessories Expansion tank	ACC4 - Zubehör Expansionsfaß	U2
ACC5-R		ACC5	ACC5 - Accessori sistema scambiatore	ACC5 - Accessories - Cooling Unit	ACC5 - Zubehör Kühlanlage	U5
		ACC6	ACC6 - Accessori Lubrificazione Forzata BEARING	ACC6 - Accessories - Forced lubrication - BEARING	ACC6 - Zubehör Zwangsschiemierung BEARING	U13
		ACC6A	ACC6A - Accessori Lubrificazione Forzata GEAR	ACC6A - Accessories - Forced lubrication - GEAR	ACC6A - Zubehör Zwangsschiemierung GEAR	U16
ACC7-R		ACC7A	Accessori idraulici Vibration Sensor	Hydraulic accessories Vibration Sensor	Hydraulikzubehör - Vibration Sensor	U18
		ACC7B	Accessori idraulici Vibration SWITCH	Hydraulic accessories Vibration SWITCH	Hydraulikzubehör - Vibration SWITCH	U19
		ACC7C	Accessori idraulici FILLING	Hydraulic accessories FILLING	Hydraulikzubehör - FILLING	U20
		ACC7D	Accessori idraulici PARTICLE MAGNETIC	Hydraulic accessories PARTICLE MAGNETIC	Hydraulikzubehör PARTICLE MAGNETIC	U21
		ACC7E	Accessori idraulici DRAIN	Hydraulic accessories DRAIN	Hydraulikzubehör - DRAIN	U22
		ACC7F	Accessori idraulici BREATHER	Hydraulic accessories BREATHER	Hydraulikzubehör BREATHER	U23
		ACC7G	Accessori idraulici LEVEL	Hydraulic accessories LEVEL	Hydraulikzubehör - LEVEL	U24
		ACC7H	Accessori idraulici HEATER	Hydraulic accessories HEATER	Hydraulikzubehör - HEATER	U25
		ACC7I1	Accessori idraulici TEMPERATURE SENSOR	Hydraulic accessories TEMPERATURE SENSOR	Hydraulikzubehör TEMPERATURE SENSOR	U26
		ACC7I2	Accessori idraulici TEMPERATURE SWITCH	Hydraulic accessories TEMPERATURE SWITCH	Hydraulikzubehör TEMPERATURE SWITCH	U27
		ACC7I3	Accessori idraulici TEMPERATURE TERMOWELL	Hydraulic accessories TEMPERATURE TERMOWELL	Hydraulikzubehör TEMPERATURE TERMOWELL	U28
		ACC7L	Accessori idraulici FILTER	Hydraulic accessories FILTER	Hydraulikzubehör - FILTER	U29
		ACC7M1	Accessori idraulici PRESSURE SENSOR	Hydraulic accessories PRESSURE SENSOR	Hydraulikzubehör PRESSURE SENSOR	U30
		ACC7M2	Accessori idraulici PRESSURE SWITCH	Hydraulic accessories PRESSURE SWITCH	Hydraulikzubehör PRESSURE SWITCH	U31
		ACC7M3	Accessori idraulici PRESSURE Differential gauge	Hydraulic accessories PRESSURE Differential gauge	Hydraulikzubehör PRESSURE Differential gauge	U32
		ACC7N1	Accessori idraulici FLOW SENSOR	Hydraulic accessories FLOW SENSOR	Hydraulikzubehör - FLOW SENSOR	U33
		ACC7N2	Accessori idraulici FLOW SWITCH	Hydraulic accessories FLOW SWITCH	Hydraulikzubehör - FLOW SWITCH	U34
		ACC7N3	Accessori idraulici FLOW VISUAL	Hydraulic accessories FLOW VISUAL	Hydraulikzubehör - FLOW VISUAL	U35
		ACC7O	Accessori idraulici COOL	Hydraulic accessories COOL	Hydraulikzubehör - COOL	U37
		ACC7P	Accessori idraulici LEVEL-BREATHER	Hydraulic accessories LEVEL-BREATHER	Hydraulikzubehör LEVEL-BREATHER	U38
ACC7Z	Accessori idraulici GENERIC	Hydraulic accessories GENERIC	Hydraulikzubehör GENERIC	U39		
ACC8-R		ACC8	ACC8 - Accessori - Tipo Tenute	ACC8 - Accessories - Seal Type	ACC8 - Zubehör - Typ von Dichtung	U41
		ACC8A	Accessori - Static Seal COMPOUND	Accessories - Static Seal COMPOUND	Zubehör - Static Seal COMPOUND	U45
OPT		OPT	OPT - Opzioni Materiale degli anelli di tenuta	OPT - Options - Materials of Seals	OPT - Optionen Dichtungsstoffe	U46
ACC9-R		ACC9A	Accessori generali - Coperchio di ispezione	Accessories custom - Inspection Cover	Zubehör custom - Inspektionsdeckel	U49
		ACC9B	Accessori generali - Flangia freno	Accessories custom - Brake Flange	Zubehör custom - Bremsflansch	U49
		ACC9C	Accessori generali - Base motore	Accessories custom - Motor Mount	Zubehör custom - Motorbasis	U51
ESTREMITÀ SUPPLEMENTARI ADDITIONAL SHAFT EXTENSIONS ZUSÄTZLICHE WELLENENDE						U53





ACC4

**ACC4 - Accessori -
Vaso Espansione**

**ACC4 - Accessories -
Expansion tank**

**ACC4 - Zubehör -
Expansionsfäß**

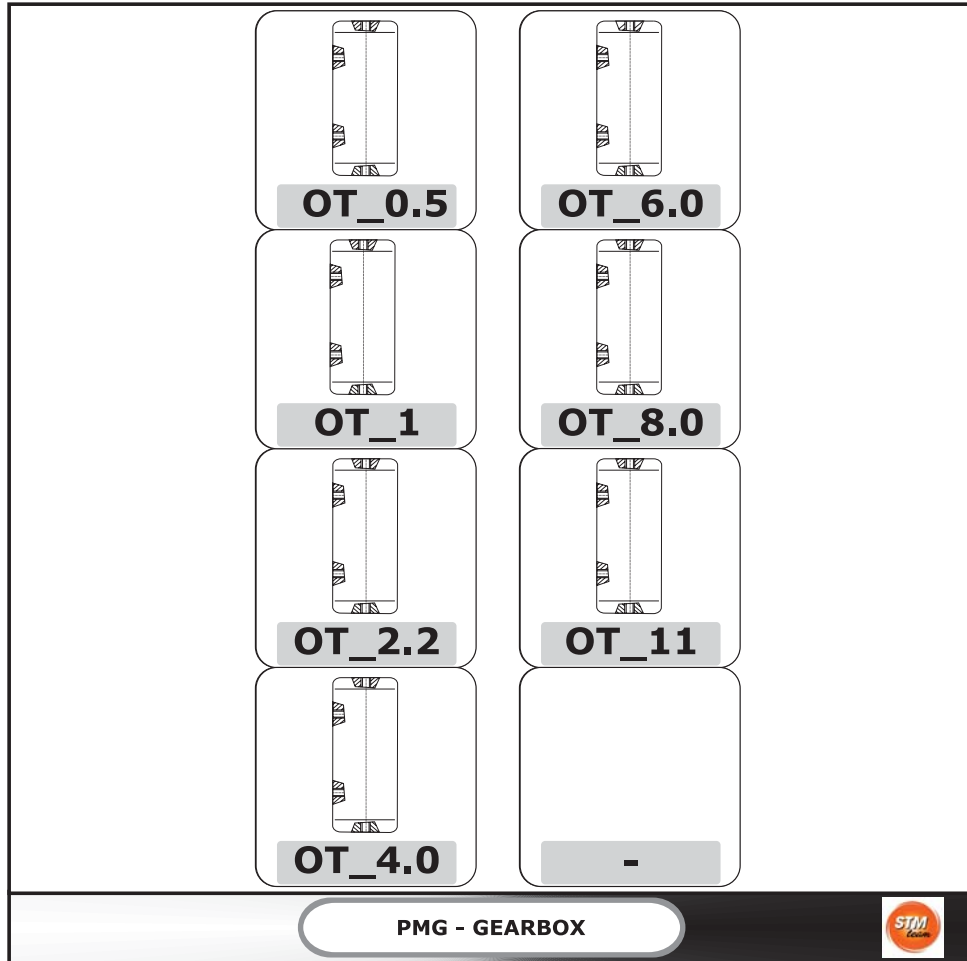

E' possibile richiedere diverse tipologie di dispositivi per consentire la dilatazione termica dell'olio.

Possono essere forniti i seguenti accessori e dispositivi:

It is possible to request various types of devices to allow the oil thermal expansion.

Some devices can optionally be provided:

Es können verschiedene Vorrichtungstypen angefordert werden, um die Wärmeausdehnung des Öls zu ermöglichen.

Folgende Zubehörteile und Vorrichtungen können geliefert werden:

Code Designation	Code ORDER	I	GB	DE
OT_0.5		= Vaso espansione - 0.5 litri	= Expansion tank 0.5 - l	= Expansionsfäß - 0.5 - l
OT_1		= Vaso espansione - 1.0 litri	= Expansion tank 1.0 - l	= Expansionsfäß - 1.0 - l
OT_2.2		= Vaso espansione - 2.2 litri	= Expansion tank 2.2 - l	= Expansionsfäß - 2.2 - l
OT_4.0		= Vaso espansione - 4.0 litri	= Expansion tank 4.0 - l	= Expansionsfäß - 4.0 - l
OT_6.0		= Vaso espansione - 6.0 litri	= Expansion tank 6.0 - l	= Expansionsfäß - 6.0 - l
OT_8.0		= Vaso espansione - 8.0 litri	= Expansion tank 8.0 - l	= Expansionsfäß - 8.0 - l
OT_11		= Vaso espansione - 11.0 litri	= Expansion tank 11.0 - l	= Expansionsfäß - 11.0 - l



Scelta Grandezza OT
OT selection
OT Auswahl

Differenza temperatura tra temperatura funzionamento riduttore e temperatura ambiente - *Temperature difference in between the operating temperature and the ambient temperature*
-Temperaturschwankungen zwischen der Betriebstemperatur und der Raumtemperatur

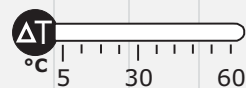

		5	10	15	20	25	30	35	40	45	50	55	60
1.0													
2.0													
3.0													
4.0													
5.0													
6.0													
7.0													
8.0													
9.0													
10.0													
11.0													
12.0													
13.0													
14.0													
15.0													
16.0													
17.0													
18.0													
19.0													
20.0													
21.0													
22.0													
23.0													
24.0													
25.0													
26.0													
27.0													
28.0													
29.0													
30.0													
31.0													
32.0													
33.0													
34.0													
35.0													
36.0													
37.0													
38.0													
39.0													
40.0													
41.0													
42.0													
45.0													
50.0													
60.0													
70.0													
80.0													
90.0													
100.0													
110.0													
120.0													
130.0													
140.0													
150.0													
160.0													
170.0													
180.0													
190.0													

05

1

2.2

4.0

6.0

8.0

11



Litri Riduttore
Gearbox liters
Liter der
Getriebe





OT 05

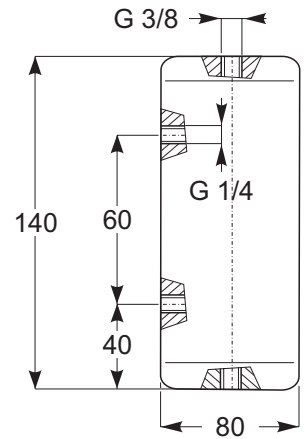

OT 1

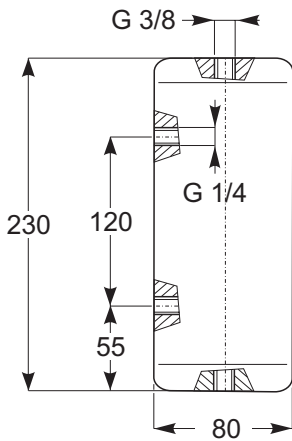

OT 2.2

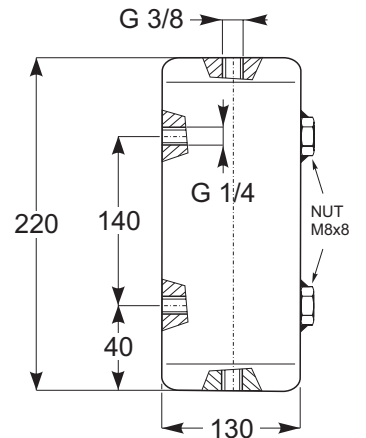

OT 4.0

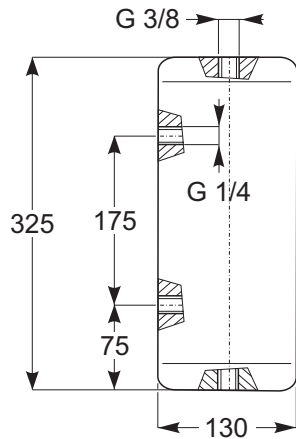

OT 6.0

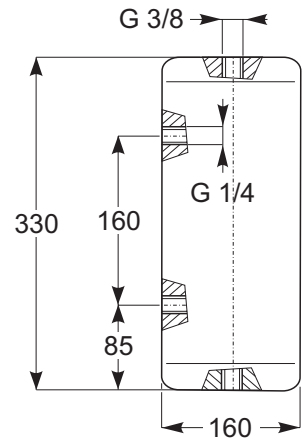

OT 8.0

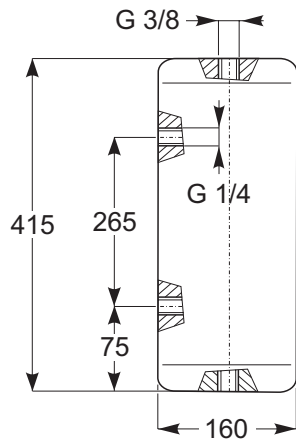

OT 11

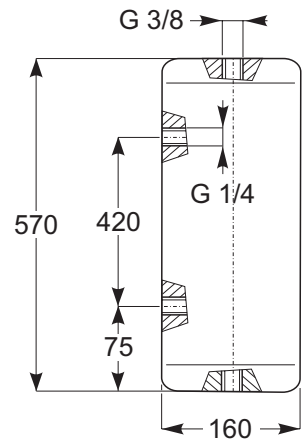

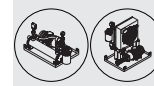

ACC5	ACC5 - Accessori - sistema con scambiatore	ACC5 - Accessories - Cooling Unit	ACC5 - Zubehör - Kühlanlage
-------------	---------------------------------------------------	------------------------------------------	------------------------------------

-	RFW1	RFW4	RFA1	RFA4
	RFW2	RFW5	RFA2	RFA5
		da fare		
	RFW3	RFW6	RFA3-A	RFA6
		da fare		
		RFW7	RFA3-B	RFA7
		da fare		
		RFW8		

PMG - GEARBOX

E' possibile richiedere diverse tipologie di dispositivi per consentire il raffreddamento dell'olio, utilizzando degli scambiatori di calori esterni al riduttore.

It is possible to request various types of devices to allow the cooling of the oil, by using heat exchangers outside the gearbox.

Es können verschiedene Vorrichtungstypen angefordert werden, um die Abkühlung des Öls unter Einsatz von extern am Getriebe angeordneten Wärmetauschern zu ermöglichen.

Possono essere forniti i seguenti accessori e dispositivi:

Some devices can optionally be provided:

Folgende Zubehörteile und Vorrichtungen können geliefert werden:

Code Designation	Code ORDER	I	GB	DE
RFW1		= RFW1 - sistema con scambiatore acqua-olio	= RFW1 - water/oil exchanger	= RFW1 - System mit Wasser-/Ölaustauscher
RFW2		= RFW2 - sistema con scambiatore acqua-olio	= RFW2 - water/oil exchanger	= RFW2 - System mit Wasser-/Ölaustauscher
RFW3		= RFW3 - sistema con scambiatore acqua-olio	= RFW3 - water/oil exchanger	= RFW3 - System mit Wasser-/Ölaustauscher
RFW4		= RFW4 - sistema con scambiatore acqua-olio	= RFW4 - water/oil exchanger	= RFW4 - System mit Wasser-/Ölaustauscher
RFW5		= RFW5 - sistema con scambiatore acqua-olio	= RFW5 - water/oil exchanger	= RFW5 - System mit Wasser-/Ölaustauscher
RFW6		= RFW6 - sistema con scambiatore acqua-olio	= RFW6 - water/oil exchanger	= RFW6 - System mit Wasser-/Ölaustauscher
RFW7		= RFW7 - sistema con scambiatore acqua-olio	= RFW7 - water/oil exchanger	= RFW7 - System mit Wasser-/Ölaustauscher
RFW8		= RFW8 - sistema con scambiatore acqua-olio	= RFW8 - water/oil exchanger	= RFW8 - System mit Wasser-/Ölaustauscher
RFA1		= RFA1 - sistema con scambiatore aria-olio	= RFA1 - air/oil exchanger	= RFA1 - System mit Luft-/Ölaustauscher
RFA2		= RFA2 - sistema con scambiatore aria-olio	= RFA2 - air/oil exchanger	= RFA2 - System mit Luft-/Ölaustauscher
RFA3-A		= RFA3-A - sistema con scambiatore aria-olio	= RFA3-A - air/oil exchanger	= RFA3-A - System mit Luft-/Ölaustauscher
RFA3-B		= RFA3-B - sistema con scambiatore aria-olio	= RFA3-B - air/oil exchanger	= RFA3-B - System mit Luft-/Ölaustauscher
RFA4		= RFA4 - sistema con scambiatore aria-olio	= RFA4 - air/oil exchanger	= RFA4 - System mit Luft-/Ölaustauscher
RFA5		= RFA5 - sistema con scambiatore aria-olio	= RFA5 - air/oil exchanger	= RFA5 - System mit Luft-/Ölaustauscher
RFA6		= RFA6 - sistema con scambiatore aria-olio	= RFA6 - air/oil exchanger	= RFA6 - System mit Luft-/Ölaustauscher
RFA7		= RFA7 - sistema con scambiatore aria-olio	= RFA7 - air/oil exchanger	= RFA7 - System mit Luft-/Ölaustauscher



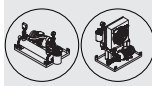

1.0 - Gruppo di raffreddamento

Il raffreddamento con scambiatore di calore può essere suddiviso in due tipologie principali: con scambiatore acqua-olio e con scambiatore aria olio, ogni categoria è divisa in più grandezze, con potenze di scambio diversificate. Ogni gruppo di raffreddamento è fornito separatamente al riduttore; i tubi di collegamento tra riduttore ed impianto non sono a carico GSM.

1.0 - Cooling Unit

Water/oil and air/oil heat exchangers are available in a range of different sizes and heat exchange capacities. Each cooling unit is supplied separate from the gear unit; pipes or hoses for connection to plant must be provided by GSM.

1.0 - Kühlanlage

Die Kühlung mittels Wärmeaustauschers lässt sich in zwei Haupttypologien unterteilen: mit Wasser-/Ölaustauscher und Luft-/Ölaustauscher. Jede Kategorie ist in mehrere Größen unterteilt, die unterschiedliche Austauschleistungen aufweisen. Jedes Kühlaggregat wird in vom Getriebe getrennter Form geliefert; die Verbindungsleitungen zwischen Getriebe und Anlage gehen nicht zu Lasten der GSM.

RFW

1.1 - RFW - sistema con scambiatore acqua-olio

1.1.1 Generalità

Sempre più spesso è indispensabile raffreddare l'olio con acqua se si ha sufficiente disponibilità d'acqua pulita.

In alcuni casi, poi, non è possibile collegare lo scambiatore olio-acqua direttamente allo scarico a causa della presenza nel circuito di colpi d'ariete, e si è costretti a realizzare un circuito separato con una pompa autonoma di circolazione, tubazioni, pressostato ed impianto elettrico.

Per questi casi, ora sempre più frequenti, GSM S.p.A. ha provveduto inserendo nella propria produzione i gruppi autonomi di raffreddamento serie RFW, che risolvono nel migliore dei modi il compito di raffreddare l'olio, indipendentemente dall'impianto idraulico primario.

L'unità è stata studiata per raffreddare l'olio e consiste in un scambiatore a fascio tubiero che, ponendo a contatto l'olio messo in circolazione dalla motopompa con la serpentina dell'acqua, asporta il calore ceduto.

Tutte le parti metalliche sono protette da verniciatura a polvere per garantire una lunga durata agli agenti atmosferici.

Nell'esecuzione standard l'unità è fornita con tutti i particolari assemblati su un telaio.

1.1.2 Stato fornitura e caratteristiche tecniche

Le unità di raffreddamento serie RFW standard sono composte da:

- 1 - Uno scambiatore di calore acqua-olio;
- 2 - Una motopompa composta da un motore a 4 poli in forma B3/B5, alimentazione standard trifase 230-400V 50 hz e da una pompa ad ingranaggi o a vite;
- 3 - Manometro 0-16 bar montato fra pompa e scambiatore di calore;
- 4 - Termometro analogico 0-120 °C, montato in uscita dallo scambiatore;
- 5 - Pressostato di minima con contatti in scambio, montato fra pompa e scambiatore di calore;
- 6 - Filtro, in mandata al serbatoio, per la pulizia dell'olio scaricato;
- 7 - Indicatore elettrico di intasamento

A – Aspirazione della pompa;

M – Mandata della pompa.

1.1 - RFW - water/oil exchanger

1.1.1 General features

If sufficient clean water is available, it is often required to cool down oil with water. Moreover, in some cases it is not possible to connect oil-water exchanger directly to the drainage due to water hammers in the circuit, and user is thus forced to set up a separated circuit with independent circulation pump, tubing, pressure switch and electric system. These cases are very frequent nowadays, this is why GSM S.p.A. has added to its product range the independent cooling units of the RFW series, that best carry out the task of cooling down oil in an independent way with respect to the main hydraulic system. This unit is designed for cooling down oil and consists in a tube bundle heat exchanger that sinks heat released from oil (circulated by motor pump) thanks to contact with water coil.

All metal parts are powder-coated to ensure long lasting protection against weather conditions.

In the standard version, the unit features all parts assembled to a frame.

1.1.2 Supply scope and specifications

Standard cooling units of the RFW series consist of:

- 1 - A water-oil heat exchanger;
- 2 - A motor pump made of a 4-pole motor rated B3/B5, standard three-phase 230-400V 50 Hz power and a gear or screw pump;
- 3 - 0-16 bar Pressure gauge mounted between pump and heat exchanger;
- 4 - 0-120 °C Analogue thermometer mounted at exchanger outlet;
- 5 - Minimum pressure switch with switch contacts, mounted between pump and heat exchanger;
- 6 - Filter, at tank inlet, for cleaning drained oil;
- 7 - Electrical clogging indicator

A – Pump inlet;

M – Pump outlet.

1.1 - RFW - System mit Wasser-Ölaustauscher

1.1.1 Allgemeine Informationen

Immer häufiger ist es unerlässlich das Öl mit Wasser zu kühlen, wenn ausreichend Wasser verfügbar ist. In einigen Fällen ist ein direkter Anschluss des Öl-Wasser-Wärmeaustauschers an den Anschluss aufgrund von Widerstoßen im System nicht möglich und man ist dazu gezwungen einen separaten Kreislauf mit einer eigenständigen Umlaufpumpe, Leitungen, Druckwächter und elektrischer Anlage zu realisieren. Für diese immer häufiger auftretenden Fälle hat die GSM S.p.A. autonome Kühlaggregate der Serie RFW in ihr Programm aufgenommen, die die Aufgabe der Ölkühlung, von der hydraulischen Hauptanlage unabhängig, in der besten Art und Weise erfüllen. Diese Einheit wurde für das Kühlen des Öls entwickelt und stellt sich in einem Wärmeaustauscher mit Rohrbündel dar, der die abgestrahlte Wärme ableitet, indem er das von der Motorpumpe in den Umlauf gebrachte Öl mit der Wasserrohrschlange in Kontakt bringt. Alle Metallteile sind durch eine Pulverlack-lackierung geschützt, die einen lang anhaltenden Schutz gegen Umweltbelastungen gewährt.

In der Standardversion wird die Einheit bereits mit allen am Rahmen montierten Teilen geliefert.

1.1.2 Lieferzustand und technische Eigenschaften

Die Kühleinheiten der Serie RFW Standard setzen sich aus folgenden Komponenten zusammen:

- 1 - einen Wasser-Öl-Wärmeaustauscher;
- 2 - einer Motorpumpe bestehend aus einem 4-poligem Motor in Bauform B3/B5, Standard-Drehstromversorgung 230-400V 50 Hz und einer Zahnrad- oder Schneckenpumpe;
- 3 - Manometer 0-16 bar, zwischen Pumpe und Wärmeaustauscher montiert;
- 4 - analoges Thermometer 0-120 °C, am Ausgang des Wärmeaustauschers montiert;
- 5 - Mindestdruckwächter mit Wechselskontakten, zwischen Pumpe Wärmeaustauscher montiert;
- 6 - Filter, im Zulauf zum Behälter, für die Reinigung des abgelassenen Öls
- 7 - elektrische Verstopfungsanzeige.

A – Ansaugung der Pumpe;

M – Zulauf der Pumpe.

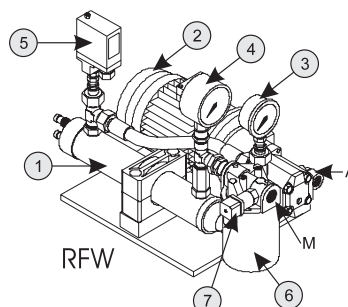

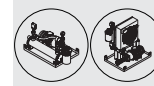

1.0 - Gruppo di raffreddamento

1.0 - Cooling Unit

1.0 - Kühlanlage

1.1.3 Dimensionamento e Caratteristiche Funzionali

Per la scelta del gruppo di raffreddamento si rimanda alla Sezione A-B-C-D-E-F-G.

1.1.3 Sizes and Functional Features
Please refer to Section A-B-C-D-E-F-G for indications on how to choose the suitable cooling unit.

1.1.3 Bemaßung und Funktionseigenschaften
Für die Wahl des richtigen Kühlaggregats verweisen wir auf die Sektion A-B-C-D-E-F-G.

CARATTERISTICHE TECNICHE

Nella Tabella sottostante riportiamo le caratteristiche tecniche

SPECIFICATIONS

The specifications are given in the table below

TECHNISCHE EIGENSCHAFTEN

In der nachstehenden Tabelle werden die technischen Eigenschaften angegeben.

Grandezza Size Baugröße Size	Peso Weight Gewicht [Kg]	Volume Olio Oil volume Ölvolumen [dm ³]	Motopompa Motor Pump Motorpumpe				Scambiatore Exchanger Wärmeaustauscher				Campo Applicazione Application Einsatzbereich	
			[*1]	[*2]	[*3]	[*4]	Connessione Olio Oil connection Ölanschluss		[*7]	[*8]	Raffreddamento Cooling Kühlung	Lubrificazione Forzata Forced Lubrication Zwangsschmierung
							[*5]	[*6]				
1	13	0,4	Ingranaggi Gear-type Zahnräder	0.37	6	230/400 50	G 1/2"	G 3/4"	G 1/2"	8-30	SI YES JA	SI YES JA
2	15	0,6		0.37	6					10-30		
3	18	1,2		0.55	16		16-30					
4	44	3,0	1.5	30	G 3/4"		G 1" 1/4	G 1"	40-110			
5	70	4,5	2.2	80	G 1" 1/4		G 1" 1/2	G 1"	80-110			
6	On request		Vite Screw-type Schnecke	7.50	135.0		G 2"	On request	G 1"	90-110		
7	On request			7.50	200.0		G 2"	On request	G 1"	180-220		
8	On request			7.50	200.0		G 2"	On request	G 1"	270-330		

Legenda/Legend/Legende
 [*1] Tipo Pompa/Pump type/Pumpentyp
 [*2] Potenza /Power/Leistung [kW]
 [*3] Portata /Flow rate/Durchsatz [dm³ / min]
 [*4] Alimentazione /Power supply/Versorgung [V / Hz]
 [*5] Aspirazione /Inlet/Ansaugung
 [*6] Mandata /Outlet/Zulauf
 [*7] Connessione Acqua /Water connection/Wasseranschluss
 [*8] Portata Acqua /Water flow rate/Wasserdurchsatz [l / min]

1.1.4 Dimensioni

1.1.4 Dimensions

1.1.4 Maße

RFW 1

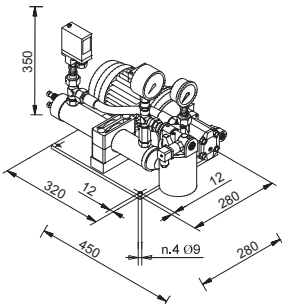

RFW 2

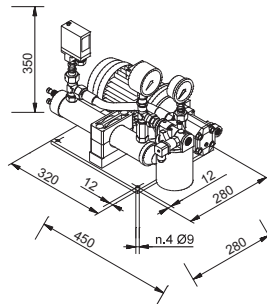

RFW 3

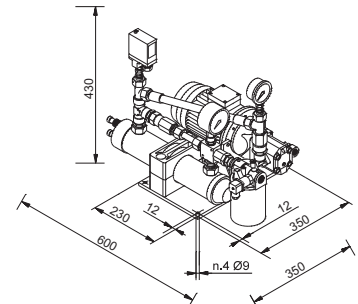

RFW 4

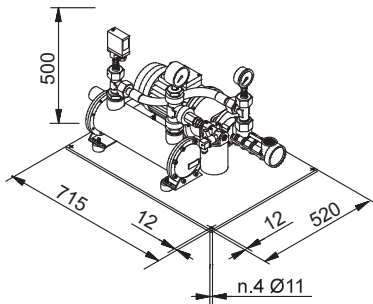

RFW 5

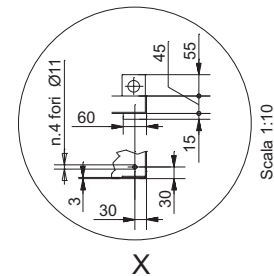
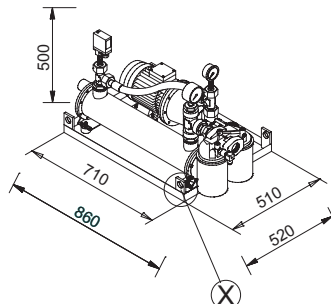

RFW 6

On request

RFW 7

On request

RFW 8

On request

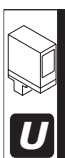

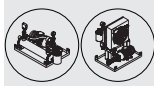

1.0 - Gruppo di raffreddamento

RFA

1.2 - RFA - sistema con scambiatore aria-olio

1.2.1 Generalità

Sempre più spesso è indispensabile raffreddare l'olio con l'aria, poiché non si ha sufficiente disponibilità d'acqua.

In alcuni casi poi, non è possibile collegare lo scambiatore aria-olio direttamente allo scarico a causa della presenza nel circuito di colpi d'ariete, e si è costretti a realizzare un circuito separato con una pompa autonoma di circolazione, tubazioni, termostato ed impianto elettrico.

La GSM S.p.A. ha provveduto inserendo nella propria produzione i gruppi autonomi di raffreddamento serie RFA, che risolvono nel migliore dei modi il compito di raffreddare l'olio, indipendentemente dall'impianto idraulico primario.

Un problema che oggi si fa sempre più pressante è il risparmio nei consumi d'energia.

Utilizzando per il raffreddamento acqua a perdere si spreca calore che l'olio ha ceduto all'acqua.

Utilizzando invece l'aria emessa dai gruppi RFA è possibile recuperare il calore ceduto dall'olio, scaldando l'ambiente in cui essi sono installati.

Oggi, il consumo dell'acqua per usi industriali ha costi sempre molto elevati ed in molti casi le aziende devono munirsi d'impianti refrigeranti in circuito chiuso dell'acqua di raffreddamento e nella maggior parte dei casi esse sono macchine frigorifere.

Il consumo d'energia di questi impianti è ingente ed è pari a circa il 30% della potenza da disperdere.

Con i gruppi autonomi serie RFA questo consumo scende al 6%, con un considerevole risparmio d'energia elettrica e quindi di costo d'esercizio, senza contare il costo iniziale notevolmente inferiore.

L'unità è stata studiata per raffreddare l'olio e consiste in un radiatore che è attraversato dal flusso d'aria generato da un ventilatore, il quale lambendo le alettature in alluminio della massa radiante asporta il calore ceduto dall'olio, che circola nel radiatore dal basso verso l'alto grazie alla pompa a vite di ricircolo. Il controllo del corretto funzionamento della macchina è regolato dai termostati che ne ottimizzano il funzionamento nel caso d'eventuali sbalzi di temperatura.

Tutte le parti metalliche sono protette da verniciatura a polvere per garantire una lunga durata agli agenti atmosferici.

Nell'esecuzione standard l'unità è fornita con tutti i particolari assemblati su un telaio palettizzabile

1.2.2 Stato fornitura e caratteristiche tecniche

Le unità di raffreddamento serie RFA standard sono composte da:

1. Uno scambiatore di calore aria-olio;
2. Una motopompa composta da un motore a 4 poli per le grandezze RFA1, RFA2, RFA3 e 2 poli per le grandezze RFA4, RFA5 in forma B3/B5, alimentazione standard trifase 230-400V 50 Hz.
Per i gruppi facenti parte dello schema A (RFA1 - RFA2 - RFA3) il motore della motopompa è il medesimo del motoventilatore.
3. SCHEMA A: Manometro 0-12 bar con funzione aggiuntiva di indicatore visivo di intasamento;
SCHEMA B: Manometro 0-16 bar montato fra pompa e scambiatore di calore ;
4. Termometro analogico 0-120 °C, montato in uscita dallo scambiatore.
5. Pressostato di minima con contatti in scambio, montato fra pompa e scambiatore di calore.
6. Filtro, in mandata al serbatoio, per la pulizia dell'olio scaricato.

1.0 - Cooling Unit

1.2 - RFA - air/oil exchanger

1.2.1 General features

When no sufficient water is available, it is more and more often indispensable to cool down oil with air.

Moreover, in some cases it is not possible to connect air-oil exchanger directly to the drainage due to water hammers in the circuit, and user is thus forced to set up a separated circuit with independent circulation pump, tubing, thermostat and electric system.

To meet the needs of these instances, GSM S.p.A. has added to its product range the independent cooling units of the RFA series, that best carry out the task of cooling down oil in an independent way with respect to the main hydraulic system.

Nowadays, energy-saving is a major issue and using water for cooling without recycling it means wasting the heat released by oil to water. While, using air issued by the RFA units, it is possible to recover the heat released by oil and use it to heat the room where they are installed. Water for industrial use is quite expensive and in many cases businesses need to set up closed-loop water cooling systems and most of the time they are refrigerating machines. Power consumption of these systems is huge, equal to about 30% of power to be wasted. With RFA series independent units this consumption is reduced to 6%, with a considerable saving in power and thus in running costs and with a remarkably lower starting cost. The unit is designed to cool down oil and consists in a radiator that is in the air flow generated by a fan; while oil is circulated in the radiator from bottom up by the recirculation screw pump, oil heat is dissipated by the air flow lapping on the aluminium fins of the radiator core. Machine correct operation is controlled by thermostats optimising its operation in case of any sudden change of temperature.

All metal parts are powder-coated to ensure long lasting protection against weather conditions.

In the standard version, the unit features all parts assembled to a frame which can be placed on a pallet.

1.2.2 Supply scope and specifications

Standard cooling units of the RFA series consist of:

1. An air-oil heat exchanger;
2. A motor pump made of a 4-pole motor for sizes RFA1, RFA2, RFA3 and 2-pole motor for sizes RFA4, RFA5 rated B3/B5, standard three-phase 230-400V 50 Hz power. For units belonging to diagram A (RFA1 - RFA2 - RFA3) motor pump motor is the same as motor fan one.
3. DIAGRAM A: 0-12 bar Pressure gauge mounted between pump and heat exchanger; with added function of oil flow blocking display
DIAGRAM B: 0-16 bar Pressure gauge mounted between pump and heat exchanger;
4. 0-120 °C Analogous thermometer mounted at exchanger outlet.
5. Minimum pressure switch with switch contacts, mounted between pump and heat exchanger.
6. Filter, at tank inlet, for cleaning drained oil.

1.0 - Kühlanlage

1.1 - RFA - System mit Luft-/Ölaustauscher

1.2.1 Allgemeine

Informationen immer häufiger ist es unerlässlich das Öl mit Luft zu kühlen, da man nicht ausreichend Wasser verfügbar hat. In einigen Fällen ist ein direkter Anschluss des Luft-Wasser- Wärmeaustauschers an den Anschluss aufgrund von Widerstößen im System nicht möglich und man ist dazu gezwungen einen separaten Kreislauf mit einer eigenständigen Umlaufpumpe, Leitungen, Thermostat und elektrischer Anlage zu realisieren. Die GSM S.p.A. hat autonome Kühlaggregate der Serie RFA in ihr Programm aufgenommen, die die Aufgabe der Ölkühlung, von der hydraulischen Hauptanlage unabhängig, in der besten Art und Weise erfüllen. Die Energieeinsparung ist heute ein Problem, dem immer mehr Bedeutung zukommt. Wird für die Kühlung nicht wiederverwendbares Wasser verwendet, geht die Wärme verloren, die das Öl ans Wasser abgegeben hat. Wird dagegen von den RFA-Aggregaten zugeführte Luft verwendet, kann die an der Öl abgegebene Wärme zurückgewonnen und für die Heizung des Raums verwendet werden, in dem sie installiert sind. Der Wasserkonsum für den industriellen Einsatz ist heute mit immer stärker steigenden Kosten verbunden und in vielen Fällen müssen sich die Firmen mit Kühlsystemen im geschlossenen Kühlwasserkreislauf ausrüsten, dabei handelt es sich in den meisten Fällen um Kühlmaschinen. Der Energieverbrauch dieser Anlagen ist beachtlich und entspricht ungefähr 30% der verbrauchbaren Leistung. Mit den autonomen Aggregaten der Serie RFA sinkt dieser Konsum auf 6% ab, eine erhebliche Einsparung bei Strom also bei Betriebskosten, ohne dabei die erheblich geringeren Anschaffungskosten zu berücksichtigen. Die Einheit wurde für die Kühlung von Öl entwickelt und besteht aus einem Kühler, der von einem durch einen Ventilator erzeugten Luftstrom durchquert wird, der die Aluminiumrippen der Kühlmasse "umspült" und die vom Öl abgegebene Wärme abnimmt. Das Öl zirkuliert dank der Schneckenpumpe im Kühler von unten nach oben. Die Steuerung des korrekten Maschinenbetriebs wird von den Thermostaten geregelt, die den Betrieb im Fall von eventuellen Temperaturschwankungen optimiert. Alle Metallteile sind durch eine Pulver- lacklackierung geschützt, die einen lang anhaltenden Schutz gegen Umweltbelastungen gewährleistet. In der Standardversion wird die Einheit bereits mit allen an einem palettierbaren Rahmen montierten Teilen geliefert.

1.2.2 Lieferzustand und technische Eigenschaften

Die Kühleinheiten der Serie RFA Standard setzen sich wie folgt zusammen:

1. Ein Luft-Öl-Wärmeaustauscher;
2. Eine Motorpumpe bestehend aus einem 4-poligem Motor für die Baugrößen RFA1, RFA2, RFA3 oder 2-poligem Motor für die Baugrößen RFA4, RFA5 in Bauform B3/B5, Standard-Drehstromversorgung 230-400V 50 Hz. Bei den Aggregaten, die zum Schema A (RFA1 - RFA2 - RFA3) gehören werden Motorpumpe und Ventilator vom selben Motor betrieben.
3. SCHEMA A: Manometer 0-12 bar, zwischen Pumpe und Wärmeaustauscher montiert; mit Zusatzanzeige für blockierten Ölfloss
SCHEMA B: Manometer 0-16 bar, zwischen Pumpe und Wärmeaustauscher montiert;
4. Analoges Thermometer 0-120 °C, am Ausgang des Wärmeaustauschers montiert;
5. Mindestdruckwächter mit Umschaltkontakten, zwischen Pumpe und Wärmeaustauscher montiert;
6. Filter, im Zulauf zum Behälter, für die Reinigung des abgelassenen Öls;

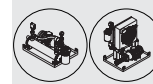

1.0 - Gruppo di raffreddamento

1.0 - Cooling Unit

1.0 - Kühlanlage

- 7. Indicatore elettrico di intasamento del filtro olio.
- 8. Scatola Morsettiera;
- 9. Termostato di regolazione;

- 7. Electrical clogging indicator of oil filter.
- 8. Terminal board box;
- 9. Adjustment thermostat;

- 7. Elektrische Verstopfungsanzeige des Ölfilters
- 8. Klemmenkasten;
- 9. Regelthermostat;

A – Aspirazione della pompa;
M – Mandata della pompa.

A – Pump inlet;
M – Pump outlet.

A – Ansaugung der Pumpe;
M – Zulauf der Pumpe.

NOTE SPECIFICHE - SCHEMA A :
Il gruppo RFA3 è fornito con sonda di temperatura e termostato.

SPECIFIC NOTES - DIAGRAM A:
RFA3 unit is supplied together with temperature probe and thermostat.

SPEZIFISCHE HINWEISE - SCHEMA A :
Das Aggregat RFA3 wird mit einer Temperatursonde und einem Thermostat geliefert.

ATTENZIONE:
Il gruppo RFA3 è fornito secondo lo schema A quando l'applicazione necessita di solo raffreddamento altrimenti è fornito RFA3 secondo lo schema B.

NOTICE:
RFA3 unit is supplied as per diagram A when the application only needs cooling, while in other cases RFA3 is supplied as per diagram B.

ACHTUNG:
Das Aggregat RFA3 wird dem Schema A gemäß geliefert, wenn die Applikation nur einer Kühlung bedarf, andernfalls wird das RFA3 dem Schema B entsprechend geliefert.

RFA

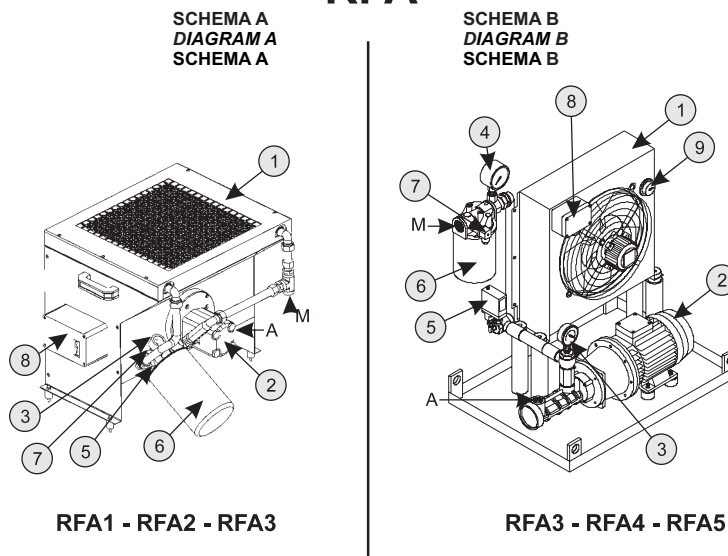

1.2.3 Dimensionamento e Caratteristiche Funzionali

Per la scelta del gruppo di raffreddamento si rimanda alla Sezione A-B-C-D-E-F-G.

1.2.3 Sizes and Functional Features

Please refer to Section A-B-C-D-E-F-G for indications on how to choose the suitable cooling unit.

1.2.3 Bemaßung und Funktionseigenschaften

Für die Wahl des richtigen Kühlaggregats verweisen wir auf die Sektion A-B-C-D-E-F-G.

CARATTERISTICHE TECNICHE

Nella Tabella sottostante riportiamo le caratteristiche tecniche

SPECIFICATIONS

The specifications are given in the table below

TECHNISCHE EIGENSCHAFTEN

In der nachstehenden Tabelle werden die technischen Eigenschaften angegeben.

Schema Diagram Schema	Grandezza Size Baugröße	Peso Weight Gewicht [Kg]	Volume Olio Oil volume Ölvolumen [dm ³]	Motopompa Motor Pump Motorpumpe				Scambiatore Exchanger Wärmeaustauscher					Campo Applicazione Application Einsatzbereich		
				[*1]	[*2]	[*3]	[*4]	Connessione Olio Oil connection Ölschluss		[*7]	[*8]	[*9]	Raffreddamento Cooling Kühlung	Lubrificazione Forzata Forced lubrication Zwangsschmier.	
A	1	20	3.0	Ingranaggi Gear-type Zahnräder	0.55	6	400 / 50 Trifase Three-phase dreiphasig	G 1/2"	G 1/2"	0.55	600	64	SI YES JA	SI YES JA	
A	2	27	3.6		0.55	13				0.75	850	68		NO NO NEIN	
A	3-A	61	5.5		1.1	34		1.1	2000	75	NO NO NEIN				
B	3-B	75	5.5	Vite Screw-type Schnecke	1.5	30		G 1"	G 1" 1/4	0.23	2700	72		SI YES JA	SI YES JA
B	4	96	15		3.0	112		G 1" 1/4	G 1" 1/2	0.23	3500	72			
B	5	118	15		3.0	112				0.56	6300	75			
B	6	127	16		3.0	160	0.9	9500	7450	79					
B	7	140	20		3.0	160			9500	79					

Legenda/Legend/Legende.

- [*1] Tipo Pompa/Pump type/Pumpentyp.
- [*2] Potenza /Power/Leistung [kW]
- [*3] Portata /Flow rate/Durchsatz [dm³ / min]
- [*4] Alimentazione /Power supply/Versorgung [V / Hz]
- [*5] Aspirazione /Inlet/Ansaugung
- [*6] Mandata /Outlet/Zulauf
- [*7] Potenza /Power/Leistung [kW]
- [*8] Portata Aria /Air flow rate/Luftdurchsatz [m³ / h]
- [*9] Rumorosità /Noise/Geräuschpegel [dB]

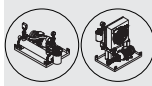

1.0 - Gruppo di raffreddamento

1.0 - Cooling Unit

1.0 - Kühlanlage

1.2.4 Dimensioni

Nelle tabelle sottostanti sono riportati gli ingombri dei gruppi:

- SCHEMA A: RFA 1, RFA 2, RFA3;
- SCHEMA B: RFA 3, RFA 4, RFA5, RFA6, RFA7;

1.2.4 Dimensions

The tables below show units overall dimensions:

- DIAGRAM A: RFA 1, RFA 2, RFA3;
- DIAGRAM B: RFA 3, RFA 4, RFA5, RFA6, RFA7;

1.2.4 Maße

In den nachstehenden Tabelle werden die Maße der Aggregate angegeben:

- SCHEMA A: RFA 1, RFA 2, RFA3;
- SCHEMA B: RFA 3, RFA 4, RFA5, RFA6, RFA7;

SCHEMA A

DIAGRAM A

SCHEMA A

RFA 1

RFA 2

RFA 3-A

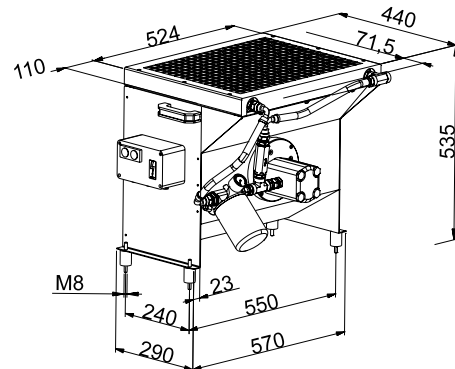
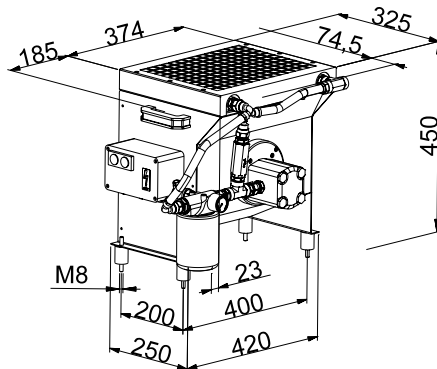
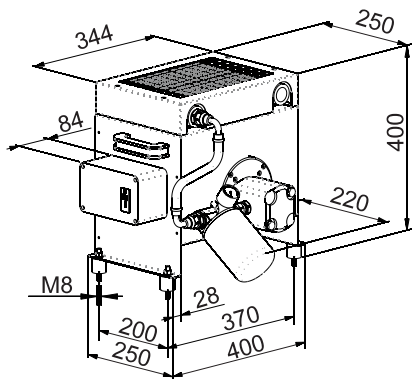

SCHEMA B

DIAGRAM B

SCHEMA B

RFA 3-B

RFA 4

RFA 5

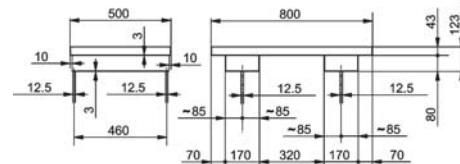
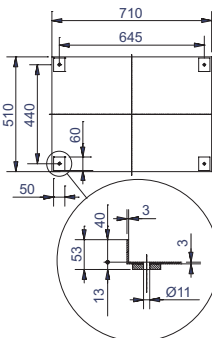
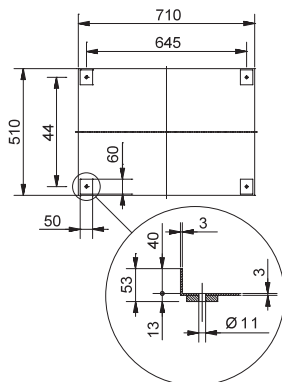
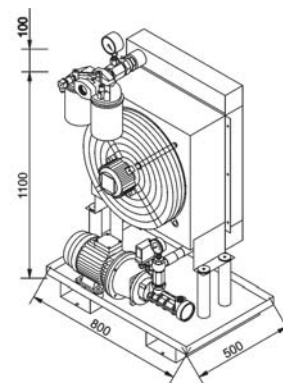
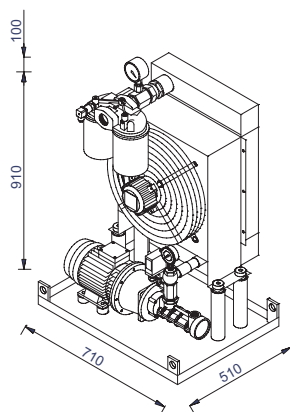
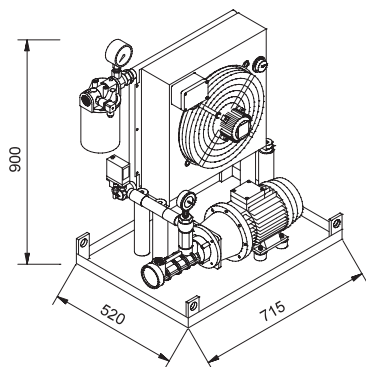

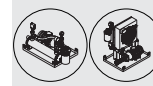

1.0 - Gruppo di raffreddamento

1.0 - Cooling Unit

1.0 - Kühlanlage

SCHEMA B

DIAGRAM B

SCHEMA B

RFA 6

RFA 7

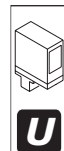
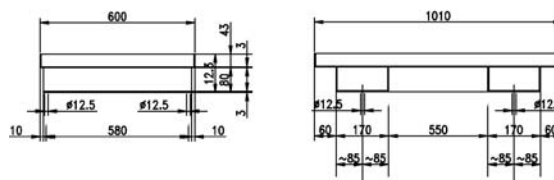
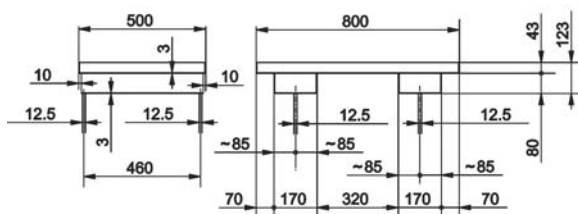
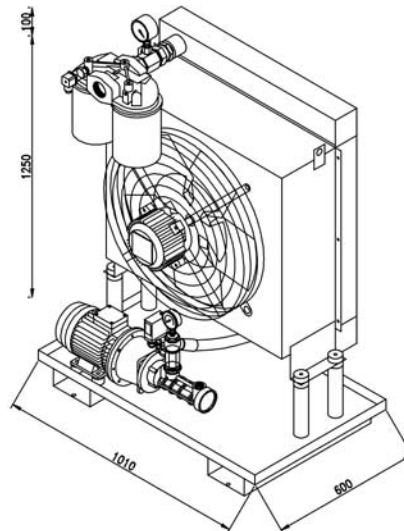
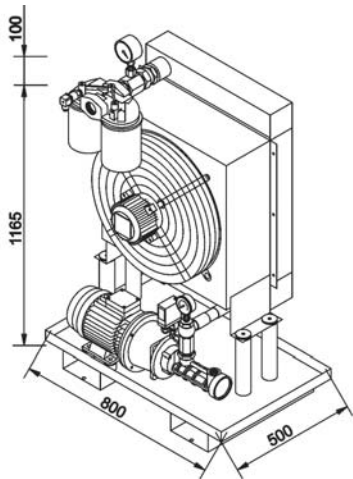



ACC6	ACC6 - Accessori - Lubrificazione Forzata - BEARING	ACC6 - Accessories - Forced lubrication - BEARING	ACC6 - Zubehör - Zwangsschmierung - BEARING
-------------	--------------------------------------------------------------------	------------------------------------------------------------------	------------------------------------------------------------

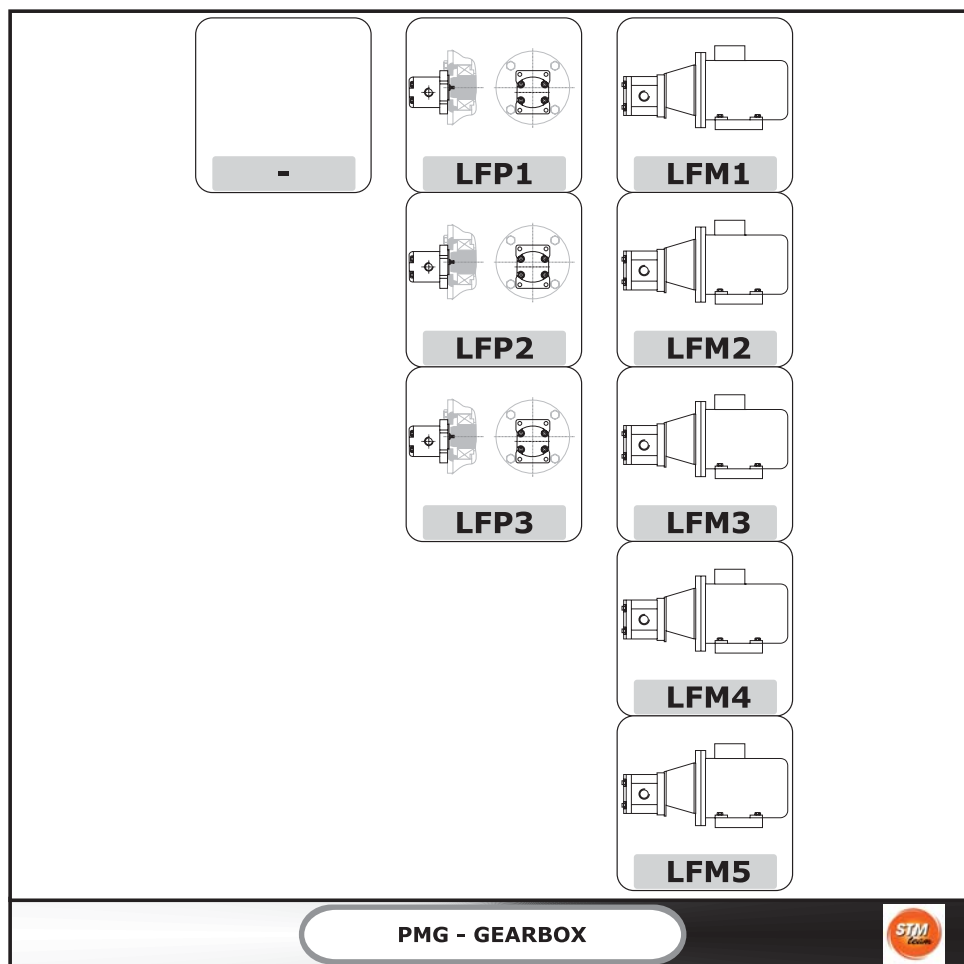

E' possibile richiedere diverse tipologie di dispositivi per consentire la lubrificazione forzata dei cuscinetti.

Possono essere forniti i seguenti accessori e dispositivi:

It is possible to request various types of devices to allow the forced lubrication of the bearings.

Some devices can optionally be provided:

Es können verschiedene Vorrichtungstypen angefordert werden, um die Zwangsschmierung der Lager zu ermöglichen.

Folgende Zubehörteile und Vorrichtungen können geliefert werden:

Code Designation	Code ORDER	I	GB	DE
LFP1		= Pompa asservita - 0.5 l/min	= Shaft-driven pump - 0.5 l/min	= Nebenpumpe- 0.5 l/min
LFP2		= Pompa asservita - 5 l/min	= Shaft-driven pump - 5 l/min	= Nebenpumpe- 1.75 l/min
LFP3		= Pompa asservita - 1.75 l/min	= Shaft-driven pump - 1.75 l/min	= Nebenpumpe- 5 l/min
LFM1		= Motopompa - 0.5 l/min	= Motor pump - 0.5 l/min	= Motorpumpe - 0.5 l/min
LFM2		= Motopompa - 5 l/min	= Motor pump - 5 l/min	= Motorpumpe - 5 l/min
LFM3		= Motopompa - 10 l/min	= Motor pump - 10 l/min	= Motorpumpe - 10 l/min
LFM4		= Motopompa - 20 l/min	= Motor pump - 20 l/min	= Motorpumpe - 20 l/min
LFM5		= Motopompa - 30 l/min	= Motor pump - 30 l/min	= Motorpumpe - 30 l/min





2.0 - Lubrificazione forzata

2.0 - Forced lubrication

2.0 - Zwangsschmierung

Lubrificazione cuscinetti superiori

Upper bearing lubrication

Schmierung der obenliegenden Lager

La lubrificazione forzata dei cuscinetti superiori viene associata alla lubrificazione forzata degli ingranaggi nel caso quest'ultima sia necessaria.

Forced lubrication for upper bearings is normally associated with forced lubrication for the gears, where necessary.

Die Zwangsschmierung der obenliegenden Lager wird mit der Zwangsschmierung der Zahnräder, für die erforderlich sind, assoziiert.

Attenzione LFP1 e LFP2:

1 - La pompa LFP1 & LFP2 è unidirezionale. L'accessorio può essere montato sul riduttore solo nel caso esso funzioni con unico senso di rotazione, il quale deve essere specificato in fase di ordine.
2 - Per applicabilità LFP...: consultare servizio tecnico.

Attention LFP1 e LFP2:

1 - The LFP1 & LFP2 pump is a one-way pump. The accessory can be installed on the gearbox only if it works in a single direction of rotation, which must be specified in the order.
2 - For LFP... applicability: contact the technical service.

Achtung LFP1 & LFP2:

1 - Die LFP1 & LFP2 ist eine einseitig gerichtete Pumpe. Das Zubehör kann nur am Getriebe montiert werden, wenn es mit einer einzigen Drehrichtung arbeitet, die bei der Bestellung angegeben werden muss.
2 - Für die LFP...Anwendungsmöglichkeit: sich an den technischen Kundendienst wenden.

2.1 - Applicabilità - LFM.

2.1 - Application - LFM.

2.1 - Applikation - LFM.

RXP

Pos. Mont. M5 - M6

Mntg. Pos. M5 - M6

Einbaulage M5 - M6

	n ₁ [min ⁻¹]	Grandezza / Size / Baugröße											
		802-810	812	814	816	818	820	822	824	826	828	830	832
RXP3	1751 - n _{1max}	G (grease)		LFM2		LFM2			LFM3			LFM4	
	1000 - 1750	G (grease)				LFM2			LFM3			LFM4	
	0 - 999	G (grease)				LFM2			LFM3			LFM4	
RXP2	1751 - n _{1max}	G (grease)		LFM2		LFM2			LFM3				
	1000 - 1750	G (grease)				LFM2			LFM3				
	0 - 999	G (grease)				LFM2			LFM3				
RXP1	1751 - n _{1max}	G (grease)		LFM2		LFM2			LFM3				
	1000 - 1750	G (grease)				LFM2			LFM3				
	0 - 999	G (grease)				LFM2			LFM3				

RXO - RXV

Pos. Mont. / Mntg. Pos. / Einbaulage M1- M5 - M6

RXO RXV	M5 M6 M1 M5 M6	n ₁ [min ⁻¹]	Grandezza / Size / Baugröße											
			802-810	812	814	816	818	820	822	824	826	828	830	832
RXO3 RXV3		0 - n _{1max}	G (grease)						LFM3			LFM4		
RXO2 RXV2		1751 - n _{1max}	G (grease)		LFM2		LFM2			LFM3			LFM4	
		1000 - 1750	G (grease)				LFM2			LFM3			LFM4	
		0 - 999	G (grease)				LFM2			LFM3			LFM4	
RXO1 RXV1		1751 - n _{1max}	G (grease)		LFM2		LFM2			LFM3				
		1000 - 1750	G (grease)				LFM2			LFM3				
		0 - 999	G (grease)				LFM2			LFM3				

Pos. Mont. / Mntg. Pos. / Einbaulage M3 - M4

	n ₁ [min ⁻¹]	Grandezza / Size / Baugröße											
		802-808	810	812	814	816	818	820	822	824	826	828	830
RXO1 RXV1	1751 - n _{1max}	G (grease)		LFM1		LFM2							
	1000 - 1750	G (grease)		LFM1		LFM2							
	0 - 999	G (grease)		LFM1		LFM2							
RXO2 RXV2	1751 - n _{1max}	G (grease)		LFM1		LFM2							
	1000 - 1750	G (grease)				LFM1			LFM2				
	0 - 999	G (grease)				LFM1			LFM2				
RXO3 RXV3		0 - n _{1max}	G (grease)		LFM2			LFM2			LFM3		

I valori di n₁ max sono riportati nel paragrafo (vedi sezione A verifiche, punto 4).

n₁ max values are listed at paragraph (see Section A verification, point 4).

Die Werte von n₁ max werden im Paragraph (siehe Abschnitt A „kontrollen“, Punkt 4, angegeben).



2.0 - Lubrificazione forzata

2.0 - Forced lubrication

2.0 - Zwangsschmierung

2.2 - Pompa asservita

2.2 - Shaft-driven pump

2.2 - Nebenpumpe

Questo sistema si realizza accoppiando la pompa direttamente ad un albero del riduttore, dal quale prende il moto, e si suddivide in 3 tipologie.

The pump is coupled directly to and driven by a gear unit shaft. There are three different types of pumps available.

Dieses System wird durch die direkte Passung der Pumpe auf eine der Getriebewellen, von der sie dann auch angetrieben wird, gestellt. Hier unterscheidet man 3 Typen.

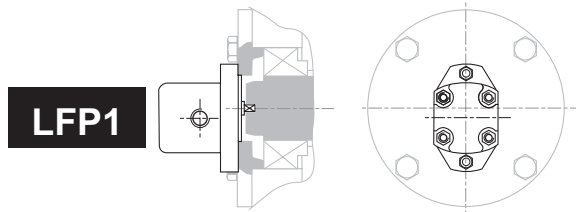

Pompa con portata di 0.5 l/min a 1500 rpm

Pump with 0.5 l/min capacity at 1500 rpm

Pumpe mit Durchsatz von 0,5 l/min bei 1500 U/min

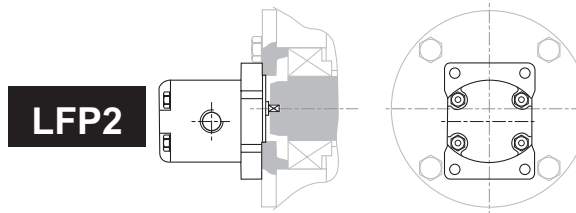

Pompa con portata di 5 l/min a 1500 rpm

Pump with 5 l/min capacity at 1500 rpm

Pumpe mit Durchsatz von 5 l/min bei 1500 U/min

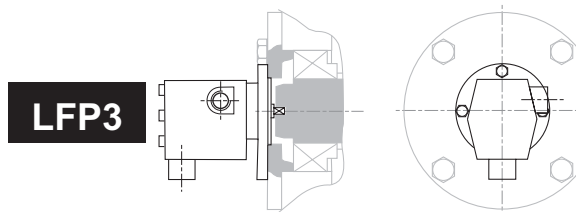

Pompa con portata di 1.75 l/min a 750 rpm

Questa pompa è particolarmente indicata per un funzionamento a basso numero di giri, viene ad esempio utilizzata nel primo stadio di riduzione cilindrico di un riduttore ortogonale

Pump with 1.75 l/min capacity at 750 rpm

This pump is especially suited for low speed operation. A typical application is the first reduction spur gear set of a helical bevel gear unit.

Pumpe mit Durchsatz von 1,75 l/min bei 750 U/min

Diese Pumpe ist besonders für einen Betrieb bei niedriger Drehzahl geeignet. Sie wird z.B. in der ersten zylindrischen Übersetzungsstufe eines Kegelstirradgetriebes verwendet.

2.3 - Motopompa

2.3 - Motor pump

2.3 - Motorpumpe

Questo sistema si realizza accoppiando un motore elettrico ad una pompa idraulica; si suddivide in 5 tipologie ed è fornibile anche separatamente al riduttore. Nelle tabelle sottostanti sono indicate le principali caratteristiche tecniche e le dimensioni di questi impianti.

This is a hydraulic pump coupled with an electric motor. Available in five different types, motor pumps are also offered as a separate product. Listed in the tables below are the most significant specifications and dimensions.

Dieses System wird durch die Passung eines Elektromotors an eine Hydraulikpumpe realisiert; es lässt sich in 5 Typologien unterteilen und kann auch getrennt vom Getriebe geliefert werden. In den nachstehenden Tabellen werden die wesentlichen technischen Eigenschaften und die Maße dieser Anlagen angegeben.

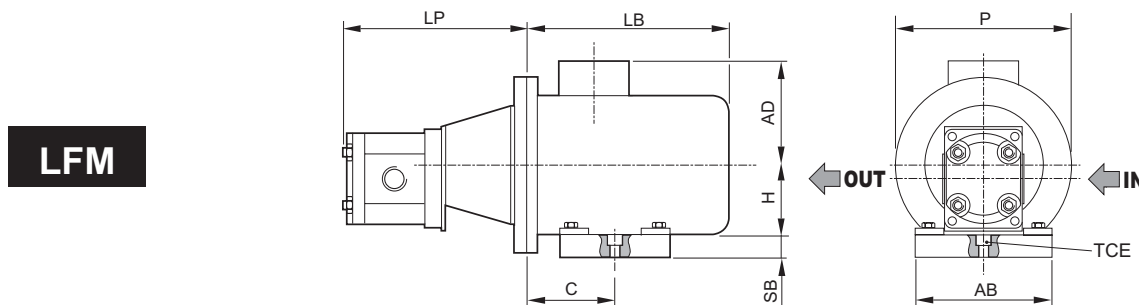

	l/min	Motor	P(kW)	A	AB	AD	BB	C	H	LB	LP	P	SB	IN	OUT	VTCE
LFM1	0.5	71A4	0.25	172	135	108	109	90	71	220	130	160	15	1/4"GAS	1/4"GAS	M8
LFM2	5				135	108	109	90	71	220	147	160	15	3/8"GAS	3/8"GAS	M8
LFM3	10	80A4	0.55	197	155	120	125	100	80	238	200	200	25	1/2"GAS	1/2"GAS	M10
LFM4	20	80B4	0.75		155	120	125	100	80	238	210	200	25	3/4"GAS	1/2"GAS	M10
LFM5	30	90S4	1.1		214	170	131	154	106	90	255	225	200	25	3/4"GAS	1/2"GAS

N.B.: la GSM si riserva di scegliere la tipologia più adatta di Pompa asservita e Motopompa per il buon funzionamento del riduttore.

NOTE: STM reserves the right to select the type of shaft-driven or motor pump deemed most appropriate for proper gear unit operation at its discretion.

HINWEIS: Die STM behält sich das Recht vor, den für den guten Getriebebetrieb angemessenen Typ der Neben- oder Motorpumpe wählen zu können.



ACC6A	ACC6A - Accessori - Lubrificazione Forzata - GEAR	ACC6A - Accessories - Forced lubrication - GEAR	ACC6A - Zubehör - Zwangsschmierung - GEAR
--------------	------------------------------------------------------------------	----------------------------------------------------------------	----------------------------------------------------------



LF.

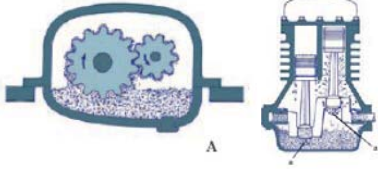

-

PMG - GEARBOX



Dove necessario è possibile fornire riduttori predisposti o completi di lubrificazione forzata. La lubrificazione forzata può essere effettuata con Pompa asservita o con Motopompa.

Where necessary, gear units are supplied with provisions for or incorporated forced lubrication. Both shaft-driven and motor-driven pumps are available.





















Wo erforderlich können die Getriebe für eine Zwangsschmierung ausgelegt oder bereits damit ausgestattet geliefert werden. Die Zwangsschmierung kann durch eine Neben- oder Motorpumpe gestellt werden.

Maggiori informazioni sugli accessori disponibili e sulla loro applicabilità sono disponibili a richiesta.

More information on the accessories available and on their applicability is available upon request.

Weitere Informationen zu den verfügbaren Zubehörteilen und deren Anwendungsmöglichkeiten erhalten Sie auf entsprechende Anfrage.

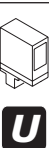

3.0 - Accessori idraulici**3.0 - Hydraulic accessories****3.0 - Hydraulikzubehör**

ACC7-R		ACC7A	Accessori idraulici - Vibration Sensor	Hydraulic accessories - Vibration Sensor	Hydraulikzubehör - Vibration Sensor	U18
		ACC7B	Accessori idraulici - Vibration SWITCH	Hydraulic accessories - Vibration SWITCH	Hydraulikzubehör - Vibration SWITCH	U19
		ACC7C	Accessori idraulici - FILLING	Hydraulic accessories - FILLING	Hydraulikzubehör - FILLING	U20
		ACC7D	Accessori idraulici - PARTICLE MAGNETIC	Hydraulic accessories - PARTICLE MAGNETIC	Hydraulikzubehör - PARTICLE MAGNETIC	U21
		ACC7E	Accessori idraulici - DRAIN	Hydraulic accessories - DRAIN	Hydraulikzubehör - DRAIN	U22
		ACC7F	Accessori idraulici - BREATHER	Hydraulic accessories - BREATHER	Hydraulikzubehör - BREATHER	U23
		ACC7G	Accessori idraulici - LEVEL	Hydraulic accessories - LEVEL	Hydraulikzubehör - LEVEL	U24
		ACC7H	Accessori idraulici - HEATER	Hydraulic accessories - HEATER	Hydraulikzubehör - HEATER	U25
		ACC7I1	Accessori idraulici - TEMPERATURE SENSOR	Hydraulic accessories - TEMPERATURE SENSOR	Hydraulikzubehör - TEMPERATURE SENSOR	U26
		ACC7I2	Accessori idraulici - TEMPERATURE SWITCH	Hydraulic accessories - TEMPERATURE SWITCH	Hydraulikzubehör - TEMPERATURE SWITCH	U29
		ACC7I3	Accessori idraulici - TEMPERATURE TERMOWELL	Hydraulic accessories - TEMPERATURE TERMOWELL	Hydraulikzubehör - TEMPERATURE TERMOWELL	U30
		ACC7L	Accessori idraulici - FILTER	Hydraulic accessories - FILTER	Hydraulikzubehör - FILTER	U31
		ACC7M1	Accessori idraulici - PRESSURE SENSOR	Hydraulic accessories - PRESSURE SENSOR	Hydraulikzubehör - PRESSURE SENSOR	U32
		ACC7M2	Accessori idraulici - PRESSURE SWITCH	Hydraulic accessories - PRESSURE SWITCH	Hydraulikzubehör - PRESSURE SWITCH	U33
		ACC7M3	Accessori idraulici - PRESSURE Differential gauge	Hydraulic accessories - PRESSURE Differential gauge	Hydraulikzubehör - PRESSURE Differential gauge	U34
		ACC7N1	Accessori idraulici - FLOW SENSOR	Hydraulic accessories - FLOW SENSOR	Hydraulikzubehör - FLOW SENSOR	U35
		ACC7N2	Accessori idraulici - FLOW SWITCH	Hydraulic accessories - FLOW SWITCH	Hydraulikzubehör - FLOW SWITCH	U36
		ACC7N3	Accessori idraulici - FLOW VISUAL	Hydraulic accessories - FLOW VISUAL	Hydraulikzubehör - FLOW VISUAL	U37
		ACC7O	Accessori idraulici - COOL	Hydraulic accessories - COOL	Hydraulikzubehör - COOL	U39
		ACC7P	Accessori idraulici - LEVEL-BREATHER	Hydraulic accessories - LEVEL-BREATHER	Hydraulikzubehör - LEVEL-BREATHER	U40
	ACC7Z	Accessori idraulici - GENERIC	Hydraulic accessories - GENERIC	Hydraulikzubehör - GENERIC	U41	



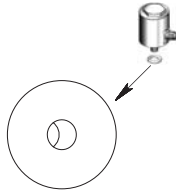

ACC7A	Accessori idraulici - Vibration Sensor	Hydraulic accessories - Vibration Sensor	Hydraulikzubehör - Vibration Sensor
--------------	---------------------------------------------------	-----------------------------------------------------	------------------------------------------------

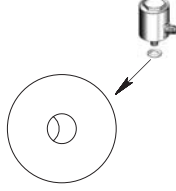
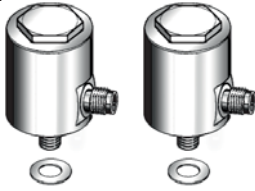
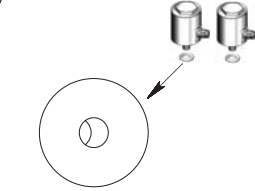
-	 A_HZ1	 A_PHZ1
	 A_HZ2	 A_PHZ2
	 A_HZ	 A_PHZ
PMG - GEARBOX		



Maggiori informazioni sugli accessori disponibili e sulla loro applicabilità sono disponibili a richiesta.

More information on the accessories available and on their applicability is available upon request.

Weitere Informationen zu den verfügbaren Zubehörteilen und deren Anwendungsmöglichkeiten erhalten Sie auf entsprechende Anfrage.

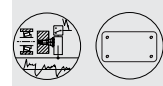

ACC7B	Accessori idraulici - Vibration SWITCH	Hydraulic accessories - Vibration SWITCH	Hydraulikzubehör - Vibration SWITCH
--------------	---------------------------------------------------	-----------------------------------------------------	------------------------------------------------

-



V_VS

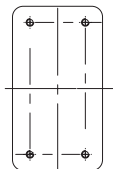

B_PVS1

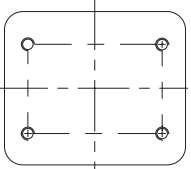

B_PVS2

PMG - GEARBOX



Maggiori informazioni sugli accessori disponibili e sulla loro applicabilità sono disponibili a richiesta.

More information on the accessories available and on their applicability is available upon request.

Weitere Informationen zu den verfügbaren Zubehörteilen und deren Anwendungsmöglichkeiten erhalten Sie auf entsprechende Anfrage.

GSM_mod.CT03-04-05-06 IGBD 0.1 

U19

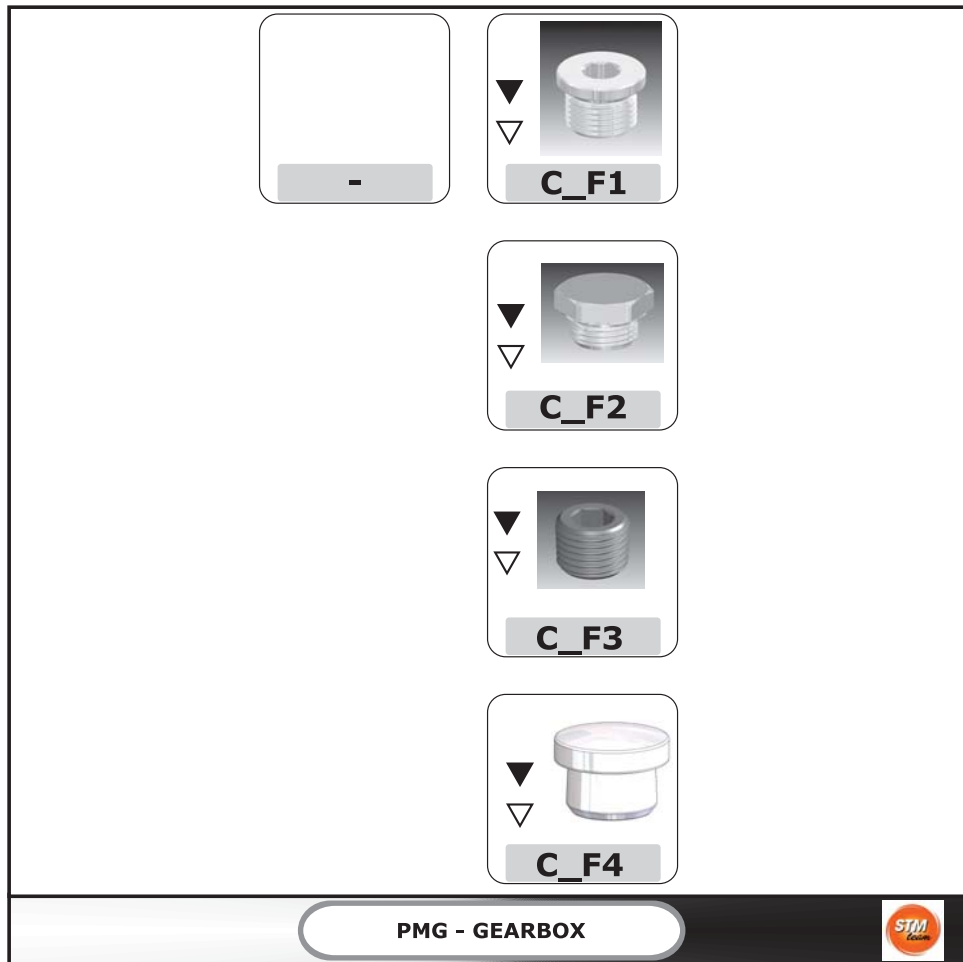

ACC7C

Accessori idraulici -
FILLINGHydraulic accessories -
FILLINGHydraulikzubehör -
FILLING

Maggiori informazioni sugli accessori disponibili e sulla loro applicabilità sono disponibili a richiesta.

More information on the accessories available and on their applicability is available upon request.

Weitere Informationen zu den verfügbaren Zubehörteilen und deren Anwendungsmöglichkeiten erhalten Sie auf entsprechende Anfrage.



ACC7D	Accessori idraulici - PARTICLE MAGNETIC	Hydraulic accessories - PARTICLE MAGNETIC	Hydraulikzubehör - PARTICLE MAGNETIC
--------------	--------------------------------------------------------	------------------------------------------------------	-------------------------------------------------

-

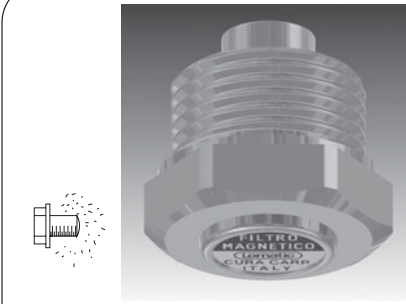

D_M1

PMG - GEARBOX



Maggiori informazioni sugli accessori disponibili e sulla loro applicabilità sono disponibili a richiesta.

More information on the accessories available and on their applicability is available upon request.

Weitere Informationen zu den verfügbaren Zubehörteilen und deren Anwendungsmöglichkeiten erhalten Sie auf entsprechende Anfrage.

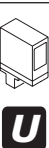

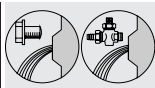

ACC7E	Accessori idraulici - DRAIN	Hydraulic accessories - DRAIN	Hydraulikzubehör - DRAIN
--------------	----------------------------------------	------------------------------------------	-------------------------------------

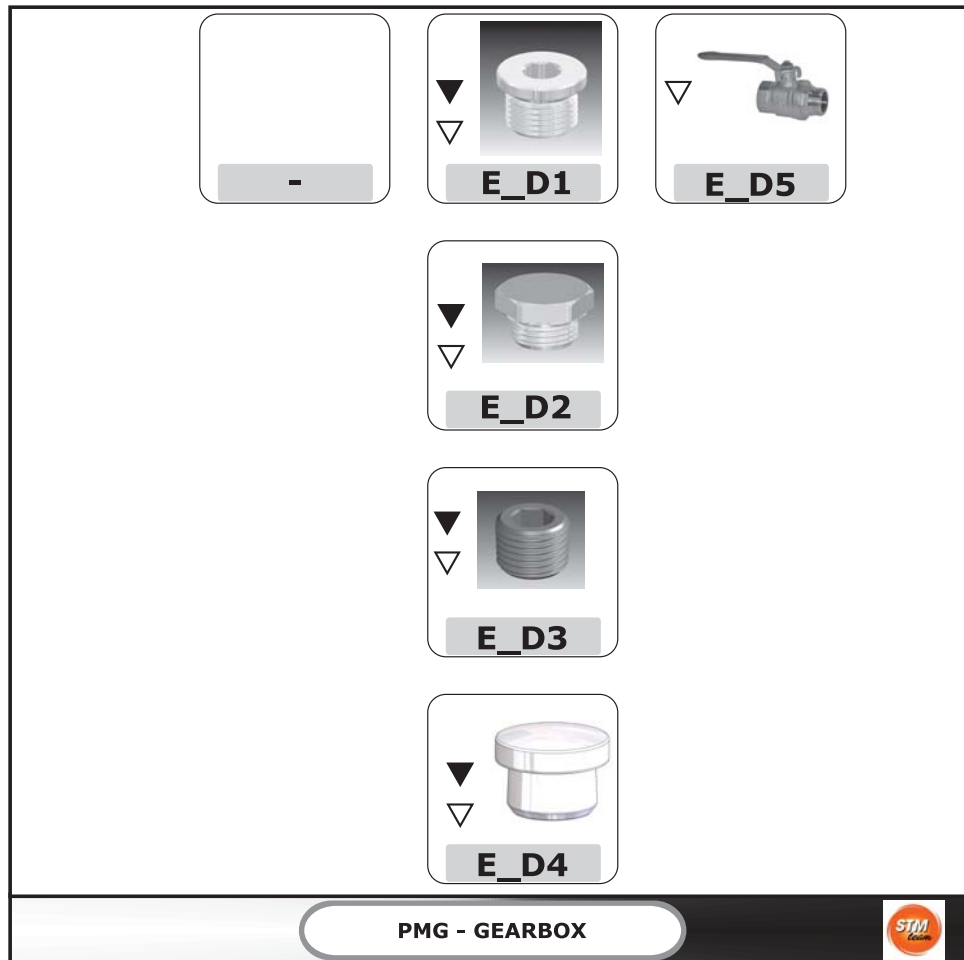

Maggiori informazioni sugli accessori disponibili e sulla loro applicabilità sono disponibili a richiesta.

More information on the accessories available and on their applicability is available upon request.

Weitere Informationen zu den verfügbaren Zubehörteilen und deren Anwendungsmöglichkeiten erhalten Sie auf entsprechende Anfrage.

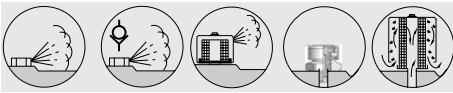

ACC7F	Accessori idraulici - BREATHER	Hydraulic accessories - BREATHER	Hydraulikzubehör - BREATHER
-------	--------------------------------	----------------------------------	-----------------------------



Maggiori informazioni sugli accessori disponibili e sulla loro applicabilità sono disponibili a richiesta.

More information on the accessories available and on their applicability is available upon request.

Weitere Informationen zu den verfügbaren Zubehörteilen und deren Anwendungsmöglichkeiten erhalten Sie auf entsprechende Anfrage.



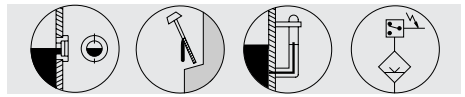

ACC7G	Accessori idraulici - LEVEL	Hydraulic accessories - LEVEL	Hydraulikzubehör - LEVEL
--------------	----------------------------------------	------------------------------------------	-------------------------------------

-	 G_L1A	 G_L3A	 G_L4A	 G_L5A	 G_L6A
	 G_L2A		 G_L4B	 G_L5B	
				 G_L5C	
				 G_L5D	

PMG - GEARBOX

Maggiori informazioni sugli accessori disponibili e sulla loro applicabilità sono disponibili a richiesta.

More information on the accessories available and on their applicability is available upon request.

Weitere Informationen zu den verfügbaren Zubehörteilen und deren Anwendungsmöglichkeiten erhalten Sie auf entsprechende Anfrage.



ACC7H	Accessori idraulici - HEATER	Hydraulic accessories - HEATER	Hydraulikzubehör - HEATER
--------------	-------------------------------------	---------------------------------------	----------------------------------



Maggiori informazioni sugli accessori disponibili e sulla loro applicabilità sono disponibili a richiesta.





More information on the accessories available and on their applicability is available upon request.

Weitere Informationen zu den verfügbaren Zubehörteilen und deren Anwendungsmöglichkeiten erhalten Sie auf entsprechende Anfrage.





ACC711	Accessori idraulici - TEMPERATURE SENSOR	Hydraulic accessories - TEMPERATURE SENSOR	Hydraulikzubehör - TEMPERATURE SENSOR
---------------	---------------------------------------------------------	-----------------------------------------------------------	------------------------------------------------------

-	 I_TPT1A	 I_TPT2A
 I_TPT1B	 I_TPT2B	 I_TPT1C
PMG - GEARBOX		



Maggiori informazioni sugli accessori disponibili e sulla loro applicabilità sono disponibili a richiesta.

More information on the accessories available and on their applicability is available upon request.

Weitere Informationen zu den verfügbaren Zubehörteilen und deren Anwendungsmöglichkeiten erhalten Sie auf entsprechende Anfrage.

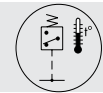

ACC712	Accessori idraulici - TEMPERATURE SWITCH	Hydraulic accessories - TEMPERATURE SWITCH	Hydraulikzubehör - TEMPERATURE SWITCH
---------------	---------------------------------------------------------	-----------------------------------------------------------	------------------------------------------------------

-	 I_TSW1A	 I_TSW2A
	 I_TSW1B	 I_TSW2B
PMG - GEARBOX		

Maggiori informazioni sugli accessori disponibili e sulla loro applicabilità sono disponibili a richiesta.

More information on the accessories available and on their applicability is available upon request.

Weitere Informationen zu den verfügbaren Zubehörteilen und deren Anwendungsmöglichkeiten erhalten Sie auf entsprechende Anfrage.





ACC713

Accessori idraulici -
TEMPERATURE
TERMOWELL

Hydraulic accessories -
TEMPERATURE
TERMOWELL

Hydraulikzubehör -
TEMPERATURE
TERMOWELL



PMG - GEARBOX



Maggiori informazioni sugli accessori disponibili e sulla loro applicabilità sono disponibili a richiesta.

More information on the accessories available and on their applicability is available upon request.

Weitere Informationen zu den verfügbaren Zubehörteilen und deren Anwendungsmöglichkeiten erhalten Sie auf entsprechende Anfrage.



ACC7L	Accessori idraulici - FILTER	Hydraulic accessories - FILTER	Hydraulikzubehör - FILTER
--------------	-----------------------------------------	-------------------------------------------	--------------------------------------

-



L_FR1A

PMG - GEARBOX



Maggiori informazioni sugli accessori disponibili e sulla loro applicabilità sono disponibili a richiesta.

More information on the accessories available and on their applicability is available upon request.

Weitere Informationen zu den verfügbaren Zubehörteilen und deren Anwendungsmöglichkeiten erhalten Sie auf entsprechende Anfrage.





ACC7M1	Accessori idraulici - PRESSURE SENSOR	Hydraulic accessories - PRESSURE SENSOR	Hydraulikzubehör - PRESSURE SENSOR
---------------	--------------------------------------------------	----------------------------------------------------	-----------------------------------------------









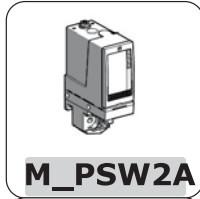

-	 M_PSR1A	 M_PSR1B
<div style="border: 1px solid black; border-radius: 15px; padding: 5px; display: inline-block;"> PMG - GEARBOX </div>		

Maggiori informazioni sugli accessori disponibili e sulla loro applicabilità sono disponibili a richiesta.

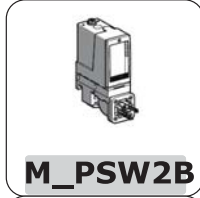
More information on the accessories available and on their applicability is available upon request.

Weitere Informationen zu den verfügbaren Zubehörteilen und deren Anwendungsmöglichkeiten erhalten Sie auf entsprechende Anfrage.

ACC7M2	Accessori idraulici - PRESSURE SWITCH	Hydraulic accessories - PRESSURE SWITCH	Hydraulikzubehör - PRESSURE SWITCH
---------------	--------------------------------------------------	----------------------------------------------------	-----------------------------------------------

-	 M_PSW1A	 M_PSW1D	 M_PSW2A
	 M_PSW1B	 M_PSW1E	 M_PSW2B
	 M_PSW1C	 M_PSW1F	 M_PSW2C
		 M_PSW1G	
PMG - GEARBOX			

Maggiori informazioni sugli accessori disponibili e sulla loro applicabilità sono disponibili a richiesta.

More information on the accessories available and on their applicability is available upon request.

Weitere Informationen zu den verfügbaren Zubehörteilen und deren Anwendungsmöglichkeiten erhalten Sie auf entsprechende Anfrage.





ACC7M3	Accessori idraulici - PRESSURE Differential gauge	Hydraulic accessories - PRESSURE Differential gauge	Hydraulikzubehör - PRESSURE Differential gauge
---------------	------------------------------------------------------------------	--------------------------------------------------------------------	---------------------------------------------------------------

-



M_PDG1A

PMG - GEARBOX



Maggiori informazioni sugli accessori disponibili e sulla loro applicabilità sono disponibili a richiesta.

More information on the accessories available and on their applicability is available upon request.

Weitere Informationen zu den verfügbaren Zubehörteilen und deren Anwendungsmöglichkeiten erhalten Sie auf entsprechende Anfrage.

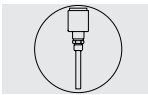

ACC7N1	Accessori idraulici - FLOW SENSOR	Hydraulic accessories - FLOW SENSOR	Hydraulikzubehör - FLOW SENSOR
---------------	----------------------------------------------	------------------------------------------------	-------------------------------------------

-



N_FSR1A

PMG - GEARBOX



Maggiori informazioni sugli accessori disponibili e sulla loro applicabilità sono disponibili a richiesta.

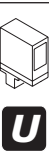

More information on the accessories available and on their applicability is available upon request.

Weitere Informationen zu den verfügbaren Zubehörteilen und deren Anwendungsmöglichkeiten erhalten Sie auf entsprechende Anfrage.





ACC7N2	Accessori idraulici - FLOW SWITCH	Hydraulic accessories - FLOW SWITCH	Hydraulikzubehör - FLOW SWITCH
---------------	----------------------------------------------	------------------------------------------------	-------------------------------------------

-	 N_FSW1A	 N_FSW2A
 N_FSW1B		
PMG - GEARBOX		



Maggiori informazioni sugli accessori disponibili e sulla loro applicabilità sono disponibili a richiesta.

More information on the accessories available and on their applicability is available upon request.

Weitere Informationen zu den verfügbaren Zubehörteilen und deren Anwendungsmöglichkeiten erhalten Sie auf entsprechende Anfrage.

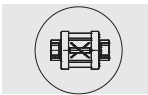

ACC7N3	Accessori idraulici - FLOW VISUAL	Hydraulic accessories - FLOW VISUAL	Hydraulikzubehör - FLOW VISUAL
---------------	----------------------------------------------	------------------------------------------------	-------------------------------------------

-



N_FVDP1A

PMG - GEARBOX



Maggiori informazioni sugli accessori disponibili e sulla loro applicabilità sono disponibili a richiesta.

More information on the accessories available and on their applicability is available upon request.

Weitere Informationen zu den verfügbaren Zubehörteilen und deren Anwendungsmöglichkeiten erhalten Sie auf entsprechende Anfrage.



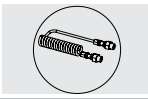

ACC70	Accessori idraulici - COOL	Hydraulic accessories - COOL	Hydraulikzubehör - COOL
--------------	---------------------------------------	-----------------------------------------	------------------------------------

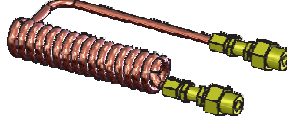
-	 O_CO1A
PMG - GEARBOX	



Maggiori informazioni sugli accessori disponibili e sulla loro applicabilità sono disponibili a richiesta.

More information on the accessories available and on their applicability is available upon request.

Weitere Informationen zu den verfügbaren Zubehörteilen und deren Anwendungsmöglichkeiten erhalten Sie auf entsprechende Anfrage.





ACC7P

**Accessori idraulici -
LEVEL-BREATHER**

**Hydraulic accessories -
LEVEL-BREATHER**

**Hydraulikzubehör -
LEVEL-BREATHER**

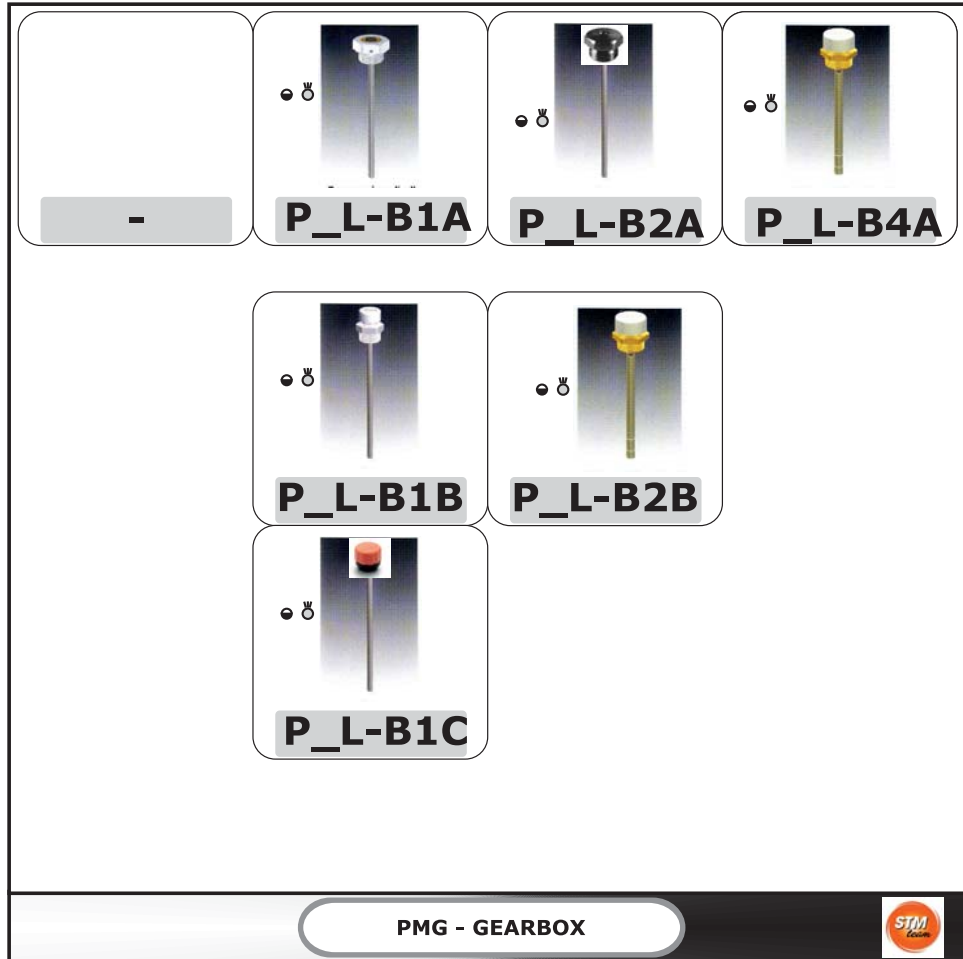



Maggiori informazioni sugli accessori disponibili e sulla loro applicabilità sono disponibili a richiesta.

More information on the accessories available and on their applicability is available upon request.

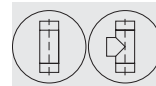
Weitere Informationen zu den verfügbaren Zubehörteilen und deren Anwendungsmöglichkeiten erhalten Sie auf entsprechende Anfrage.

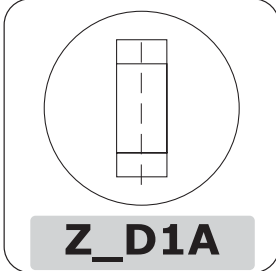
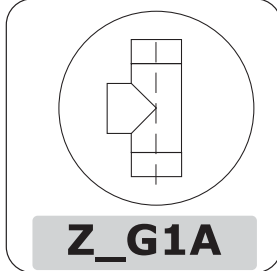

ACC7Z	Accessori idraulici - GENERIC	Hydraulic accessories - GENERIC	Hydraulikzubehör - GENERIC
--------------	------------------------------------------	--------------------------------------------	---------------------------------------

 <p style="text-align: center; background-color: #cccccc; padding: 5px;">-</p>	 <p style="text-align: center; background-color: #cccccc; padding: 5px;">Z_D1A</p>	 <p style="text-align: center; background-color: #cccccc; padding: 5px;">Z_G1A</p>
<p>PMG - GEARBOX</p>		

Maggiori informazioni sugli accessori disponibili e sulla loro applicabilità sono disponibili a richiesta.





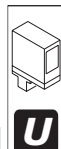

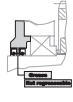

More information on the accessories available and on their applicability is available upon request.

Weitere Informationen zu den verfügbaren Zubehörteilen und deren Anwendungsmöglichkeiten erhalten Sie auf entsprechende Anfrage.

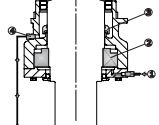
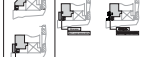
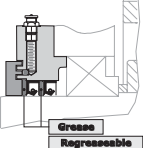

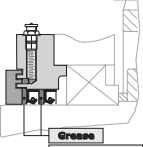

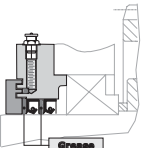
ACC8	ACC8 - Accessori - Tipo Tenute	ACC8 - Accessories - Seal Type	ACC8 - Zubehör - Typ von Dichtung
-------------	-------------------------------------------	-------------------------------------------	----------------------------------------------

<p>STM</p> 		<p>A</p> 	<p>B</p> 	
<p>GSM A_PAM</p> 	 <p style="text-align: center;">Grasso Regrassoabile</p> <p style="text-align: center;">LB1</p>	<p style="text-align: center;">DT1</p>		<p style="text-align: center;">DW</p>
<p>GSM B_ECE</p> 	<p style="text-align: center;">-</p>	 <p style="text-align: center;">Grasso Regrassoabile</p> <p style="text-align: center;">LB2</p>	<p>002 + 010</p>  <p style="text-align: center;">Grasso Not regrassoabile</p> <p style="text-align: center;">DT2</p>	
	 <p style="text-align: center;">Grasso Regrassoabile</p> <p style="text-align: center;">LB</p>	<p>A</p> 	<p>B</p> 	
		<p style="text-align: center;">DT</p>		

PMG - GEARBOX



E' possibile richiedere diverse tipologie costruttive per realizzare la tenuta dinamica del riduttore.

It is possible to request various types of manufacturing to ensure the dynamic tightness of the gearbox.

Es können verschiedene Bauarten angefordert werden, um die dynamische Dichtigkeit des Getriebes zu erhalten.

Possono essere forniti i seguenti accessori e dispositivi:

Some devices can optionally be provided:

Folgende Zubehörteile und Vorrichtungen können geliefert werden:

Code Designation	Code ORDER	I	GB	DE
LB1		= Doppio anello di tenuta con labbro parapolvere con tenuta a labirinto in Entrata	= Double dust lip seal with Labyrinth seal - Input Shaft	= Doppeldichtung mit Staublippe mit Labyrinth-Dichtung - Antriebswelle
LB2		= Doppio anello di tenuta con labbro parapolvere con tenuta a labirinto in Uscita	= Double dust lip seal with Labyrinth seal - Output Shaft	= Doppeldichtung mit Staublippe mit Labyrinth-Dichtung - Abtriebswelle
LB		= Doppio anello di tenuta con labbro parapolvere con tenuta a labirinto in Albero Entrata + Albero Uscita	= Double dust lip seal with Labyrinth seal - Input shaft + Output shaft	= Doppeldichtung mit Staublippe mit Labyrinth-Dichtung - Antriebswelle + Abtriebswelle
DT1		= Doppio anello di tenuta con labbro parapolvere in Entrata	= Double dust lip seal - Input Shaft	= Doppeldichtung mit Staublippe - Antriebswelle
DT2		= Doppio anello di tenuta con labbro parapolvere e coperchio di protezione in Uscita	= Double dust lip seal with dust protection - Output Shaft	= Doppeldichtung mit Staublippe und Schutzabdeckung - Abtriebswelle
DT		= Doppio anello di tenuta con labbro parapolvere e coperchio di protezione in Albero Entrata + Albero Uscita	= Double dust lip seal with dust protection - Input shaft + Output shaft	= Doppeldichtung mit Staublippe Antriebswelle und Schutzabdeckung + Abtriebswelle
DW		= Dry-Well	= Dry-Well	= Dichtungsstoffe



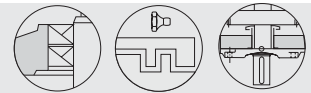

4.0 - Anelli di tenuta

4.0 - Seals

4.0 - Dichtringe

4.1 - Applicabilità

4.1 - Application

4.1 - Applikation

	RXP1	RXP2 - RXP3	RXP4	RXO1 - RXV1	RXO2 - RXV2 RXO3 - RXV3
DT1					
DT2					
DT					
LB1					
LB2					
LB					
DW	A richiesta / On request / Auf Anfrage				

4.2 - Albero Entrata

4.2 - Input shaft

4.2 - Antriebswelle

INPUT - PAM	INPUT - ECE		
Standard	Standard	Dust-proof	Radial labyrinth seal
<p>Un solo anello di tenuta con labbro parapolvere <i>One dust lip seal</i> <i>Ein einziger Dichtring mit Staublippe</i></p>	<p>Un solo anello di tenuta con labbro parapolvere e coperchio di protezione <i>One dust lip seal with dust protection</i> <i>Ein einziger Dichtring mit Staublippe und Schutzabdeckung</i></p>	<p>Doppio anello di tenuta con labbro parapolvere. <i>Double dust lip seal</i> <i>Doppeldichtung mit Staublippe</i></p>	<p>Doppio anello di tenuta con labbro parapolvere con tenuta a labirinto. <i>Double dust lip seal with Labyrinth seal</i> <i>Doppeldichtung mit Staublippe mit Labyrinth-Dichtung</i></p>
	<p>Ambiente abbastanza polveroso Medium dust load with abrasive particles Ziemlich staubiges Umfeld</p>	<p>Ambiente molto polveroso High dust load with abrasive particles Sehr staubiges Umfeld</p>	<p>Ambiente estremamente polveroso Very High dust load with abrasive particles Extrem staubiges Umfeld</p>
		<p style="background-color: black; color: white; padding: 2px;">DT1 RXO-RXV</p>	<p style="background-color: black; color: white; padding: 2px;">LB1</p>
	<p>Grease Not regreaseable</p>	<p>Grease Not regreaseable</p>	<p>Grease Regreaseable</p>
		<p>Doppio anello di tenuta con labbro parapolvere e coperchio protezione. <i>Double dust lip seal with dust protection</i> <i>Doppeldichtung mit Staublippe und Schutzabdeckung</i></p> <p>Ambiente molto polveroso. High dust load with abrasive particles Sehr staubiges Umfeld</p> <p style="background-color: black; color: white; padding: 2px;">DT1 RXP</p> <p style="text-align: center;">Grease Not regreaseable</p>	



4.0 - Anelli di tenuta

4.0 - Seals

4.0 - Dichtringe

4.3 - Albero Uscita

4.3 - Output shaft

4.3 - Abtriebswelle

OUTPUT		
Standard	Dust-proof	Radial labyrinth seal
<p>Un solo anello di tenuta con labbro parapolvere e coperchio di protezione <i>One dust lip seal with dust protection</i> <i>Ein einziger Dichtring mit Staublippe und Schutzabdeckung.</i></p> <p>Ambiente abbastanza polveroso Medium dust load with abrasive particles Ziemlich staubiges Umfeld</p>	<p>Doppio anello di tenuta con labbro parapolvere e coperchio di protezione <i>Double dust lip seal with dust protection</i> <i>Doppeldichtung mit Staublippe und Schutzabdeckung.</i></p> <p>Ambiente molto polveroso High dust load with abrasive particles Sehr staubiges Umfeld</p>	<p>Doppio anello di tenuta con labbro parapolvere con tenuta a labirinto. <i>Double dust lip seal with Labyrinth seal</i> <i>Doppeldichtung mit Staublippe und Labyrinth-Dichtung</i></p> <p>Ambiente estremamente polveroso Very High dust load with abrasive particles</p>
<p>802 ÷ 818</p> <p>Grease Not regreaseable</p>	<p>802 ÷ 818 DT2</p> <p>Grease Not regreaseable</p>	<p>LB2</p> <p>Grease Regreaseable</p>
<p>Un solo anello di tenuta con labbro parapolvere e coperchio di protezione <i>One dust lip seal with dust protection</i> <i>Ein einziger Dichtring mit Staublippe und Schutzabdeckung.</i></p> <p>Ambiente abbastanza polveroso Medium dust load with abrasive particles Ziemlich staubiges Umfeld</p>	<p>Doppio anello di tenuta con labbro parapolvere e coperchio di protezione <i>Double dust lip seal with dust protection</i> <i>Doppeldichtung mit Staublippe und Schutzabdeckung.</i></p> <p>Ambiente molto polveroso High dust load with abrasive particles Sehr staubiges Umfeld</p>	
<p>> 818</p> <p>Grease Not regreaseable</p>	<p>> 818 DT2</p> <p>Grease Not regreaseable</p>	

4.4 - Albero Entrata + Albero Uscita

4.4 - Input shaft + Output shaft

4.4 - Antriebswelle + Abtriebswelle

DT	(DT1+DT2) Doppia tenuta in entrata ed in uscita	(DT1+DT2) Double seal at input and output end	(DT1+DT2) Doppeldichtung in An- und Abtrieb
LB	(LB1+LB2) Tenuta a labirinto in entrata ed in uscita	(LB1+LB2) <i>Labyrinth seal at input and output end</i>	(LB1+LB2) Labyrinthdichtung in An- und Abtrieb

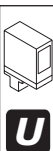

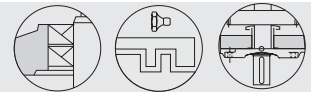

4.0 - Anelli di tenuta

4.0 - Seals

4.0 - Dichtringe

4.6 - Dry-Well

4.6 - Dry-Well

4.6 - Dichtungstoffe

DW

Questo dispositivo garantisce la tenuta dell'albero lento sporgente. E' disponibile, in posizione di montaggio M5 ed associato ad una lubrificazione forzata, solo per alcune taglie e qualche rapporto (interpellare il ns. servizio tecnico). Si rende necessario verificare/ripristinare la carica di grasso al cuscinetto inferiore dell'asse lento.

The dry-well feature prevents oil leakage at the solid output shaft. It is available for some particular sizes and ratios in mounting position M5 and in combination with forced lubrication (please contact our Engineering for more details). Please note that the grease charge of the output shaft lower bearing must be checked/refilled.

Diese Vorrichtung gewährleistet die Abdichtung der hervorstehenden Abtriebswelle. Sie ist, in der Einbaulage M5 verfügbar und an eine Zwangsschmierung gebunden, nur für einige Baugrößen und ein paar Übersetzungen verfügbar (unseren Technischen Kundendienst befragen). Hier ist eine Kontrolle/Nachfüllung der Fettfüllung des unteren Lagers der Abtriebsachse erforderlich.

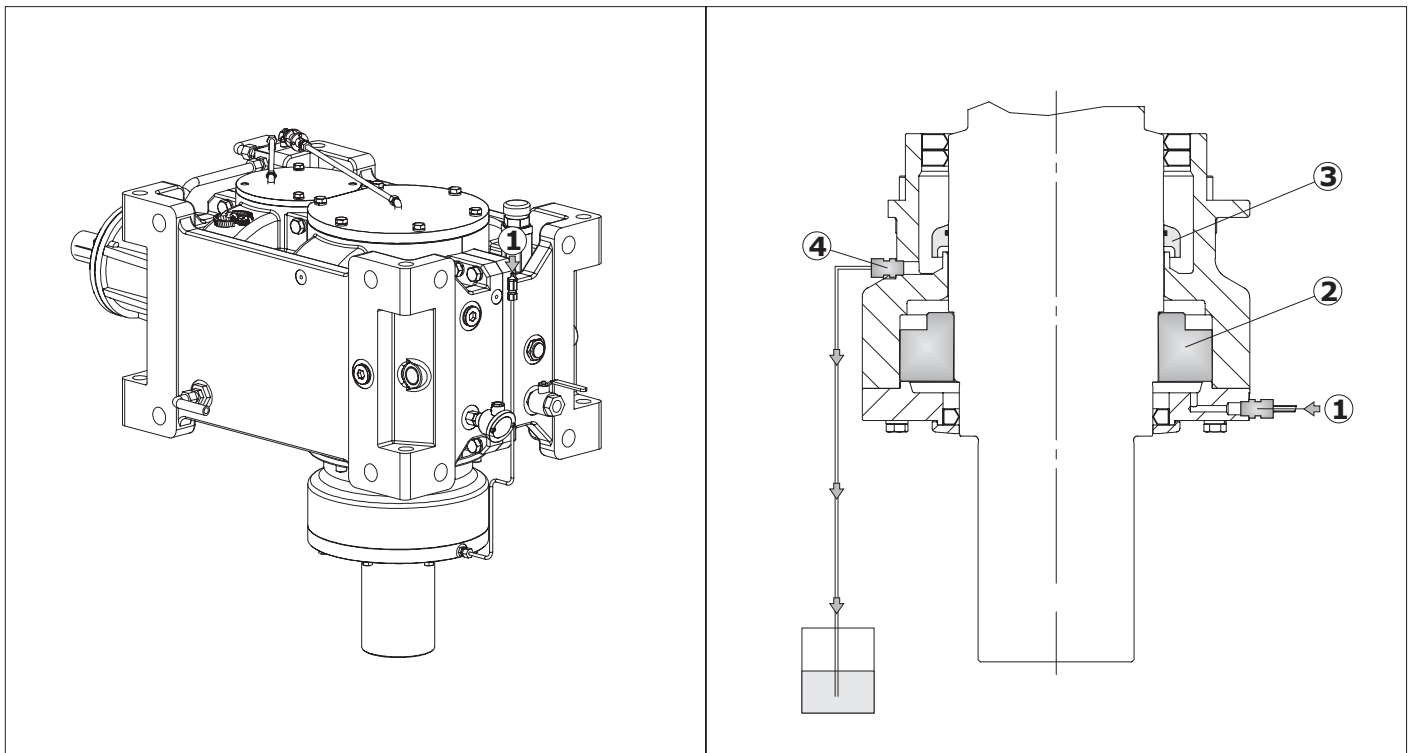

1	Ingrassatore - Cuscinetto	Grease nipple – Bearing	Schmierer – Lager
2	Cuscinetto	Bearing	Lager
3	Dispositivo Centrifugatore olio	Oil slinger device	Ölabweisringvorrichtung
4	Drenaggio olio - Sicurezza	Oil Drain - Security	Ölablass – Sicherheit



4.0 - Anelli di tenuta

4.0 - Seals

4.0 - Dichtringe

ACC8A**Accessori - Static
Seal COMPOUND****Accessories - Static
Seal COMPOUND****Zubehör - Static
Seal COMPOUND****-****SP_1A****SL_1A****PMG - GEARBOX**

Maggiori informazioni sugli accessori disponibili e sulla loro applicabilità sono disponibili a richiesta.



More information on the accessories available and on their applicability is available upon request.

Weitere Informationen zu den verfügbaren Zubehörteilen und deren Anwendungsmöglichkeiten erhalten Sie auf entsprechende Anfrage.

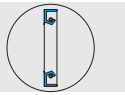
**U**

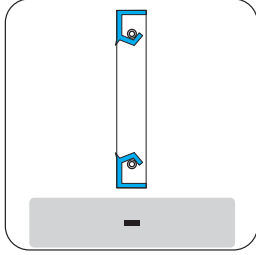
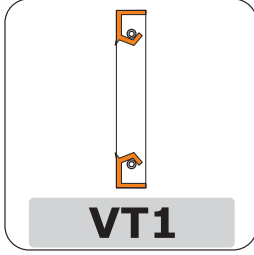
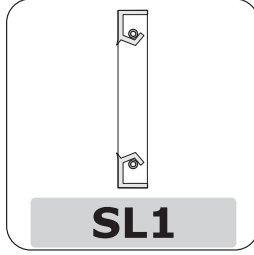
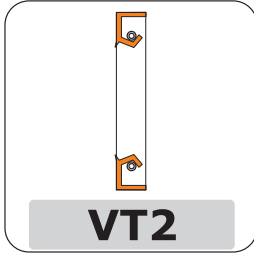
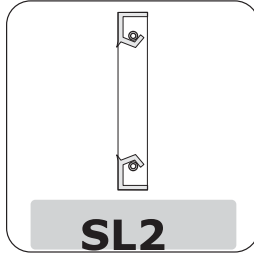
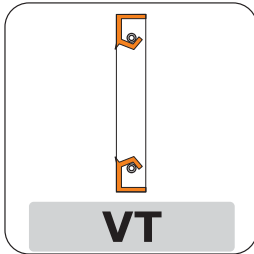
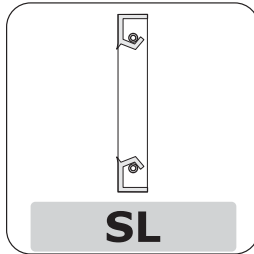

OPT	OPT - Opzioni - Materiale degli anelli di tenuta	OPT - Options - Materials of Seals	OPT - Optionen - Dichtungsstoffe
-----	--------------------------------------------------------	---------------------------------------	-------------------------------------

 -	 VT1	 SL1
	 VT2	 SL2
	 VT	 SL
PMG - GEARBOX		

E' possibile richiedere materiali opzionali per gli anelli per la tenuta dinamica del riduttore.

It is possible to request optional materials for the dynamic sealing seal rings of gearbox.

Es können Dichtringe aus optionalen Materialien für die dynamische Dichtigkeit des Getriebes angefordert werden.

Possono essere forniti i seguenti accessori e dispositivi:

Some devices can optionally be provided:

Folgende Zubehörteile und Vorrichtungen können geliefert werden:

Code Designation	Code ORDER	I	GB	DE
VT1		= Paraoli in viton in entrata	= Viton oil seals at input end	= Ölabdichtungen aus Viton im Antrieb
VT2		= Paraoli in viton in uscita	= Viton oil seals at output end	= Ölabdichtungen aus Viton im Abtrieb
VT		= Paraoli in viton in entrata ed in uscita	= Viton oil seals at input and output end	= Ölabdichtungen aus Viton im An- und Abtrieb
SL1		= Paraoli in silicone in entrata	= Input Silicon oil seals	= Eingehender Silikon-Dichtungsring
SL2		= Paraoli in silicone in uscita	= Output Silicon oil seals	= Ausgehender Silikon-Dichtungsring
SL		= Tenute in Silicone in Entrata - Uscita	= Inpu and Output Silicon oil seals	= Ein-und ausgehende Silikon-Dichtungsringe



4.0 - Anelli di tenuta

4.0 - Seals

4.0 - Dichtringe

4.1 - Applicabilità

4.1 - Application

4.1 - Applikation

	RXP1	RXP2 - RXP3	RXP4	RX01 - RXV1	RX02 - RXV2 RX03 - RXV3
VT1	A richiesta On request Auf Anfrage			A richiesta On request Auf Anfrage	
VT2					
VT					
SL1				A richiesta On request Auf Anfrage	
SL2					
SL					

4.2 - Materiale degli anelli di tenuta

4.2 - Materials of Seals

4.2 - Dichtungsstoffe

Serie Series Baureihe	OPT Opzioni - Materiale degli anelli di tenuta Options - Materials of Seals Optionen - Dichtungsstoffe	
		(Tenute STANDARD Oil Seals Standard Ölabdichtungen Standard)
RX 700	(VT1 - NBR2)	VT2 - SL1- SL2 - SL

Serie Series Baureihe	OPT Opzioni - Materiale degli anelli di tenuta Options - Materials of Seals Optionen - Dichtungsstoffe	
		(Tenute STANDARD Oil Seals Standard Ölabdichtungen Standard)
RX 800	(NBR)	VT1 - VT2 - VT - SL1- SL2 - SL

NBR1	Paraoli in NBR in entrata	NBR oil seals at input end	Ölabdichtungen aus NBR im Antrieb
NBR2	Paraoli in NBR in uscita	NBR oil seals at output end	Ölabdichtungen aus NBR im Abtrieb
NBR	Paraoli in NBR in entrata ed in uscita	NBR oil seals at input and output end	Ölabdichtungen aus NBR im An- und Abtrieb
VT1	Paraoli in viton in entrata	Viton oil seals at input end	Ölabdichtungen aus Viton im Antrieb
VT2	Paraoli in viton in uscita	Viton oil seals at output end	Ölabdichtungen aus Viton im Abtrieb
VT	Paraoli in viton in entrata ed in uscita	Viton oil seals at input and output end	Ölabdichtungen aus Viton im An- und Abtrieb
SL1	Paraoli in silicone in entrata	Input Silicon oil seals	Eingehender Silikon-Dichtungsring
SL2	Paraoli in silicone in uscita	Output Silicon oil seals	Ausgehender Silikon-Dichtungsring
SL	Paraoli in silicone in entrata ed in uscita	Input and output oil seals	Ein- und ausgehende Silikon-Dichtungsringe

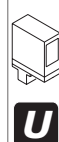

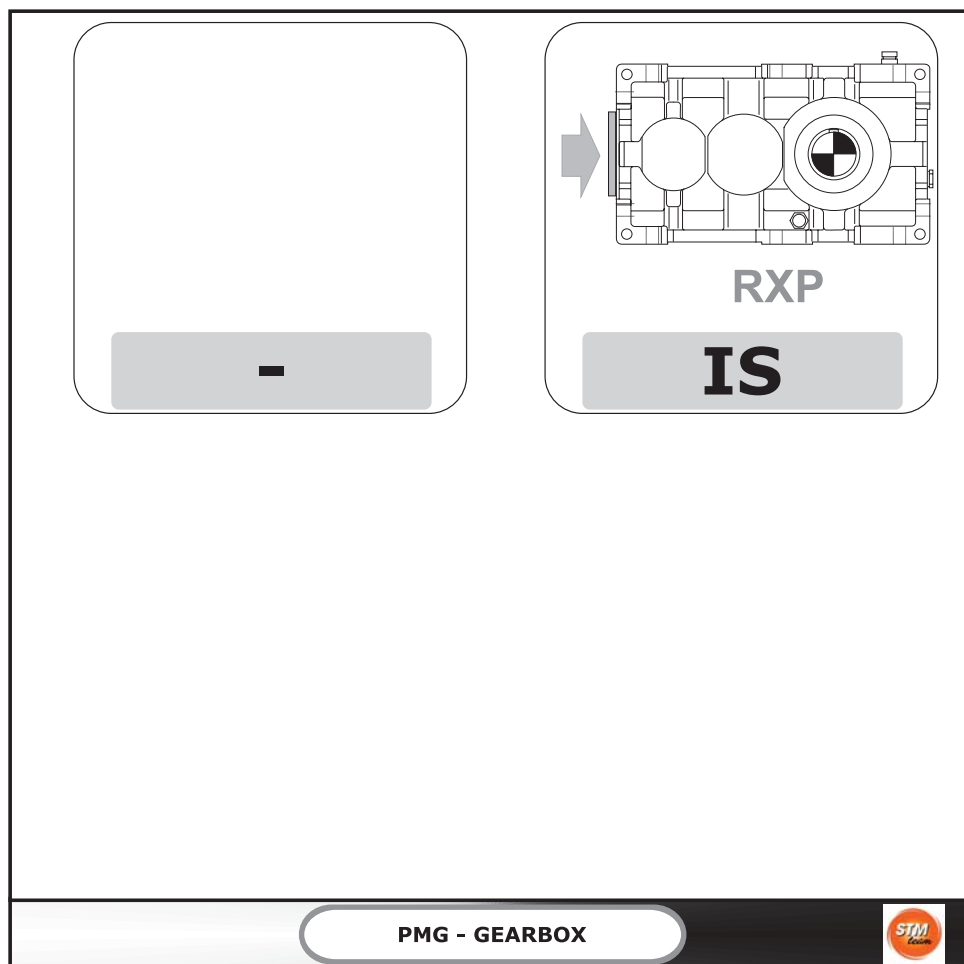

ACC9A	Accessori generali - Coperchio di ispezione	Accessories custom- Inspection Cover	Zübehör custom - Inspektionsdeckel
--------------	------------------------------------------------------------	-------------------------------------------------	-----------------------------------------------

**IS****Standard**

Sono forniti standard su RXP e RXV coperchi d'ispezione lato entrata ortogonale.

Richiesta

Per RXO e riduttori con cassa in acciaio sono fornibili a richiesta coperchi come da schema.

Standard

Inspection covers at right-angle input end supplied on RXP and RXV as standard.

On request

For RXO and steel casing gear unit, inspection covers as shown available on request.

Standard

Bei den RXP- und RXV-Getrieben gehören die Inspektionsdeckel an der Winkelantriebsseite zur Standardausstattung.

Auf Anfrage

Bei den RXO -Getrieben mit Stahlgehäuse können die Deckel auf Anfrage geliefert werden, siehe Schema.

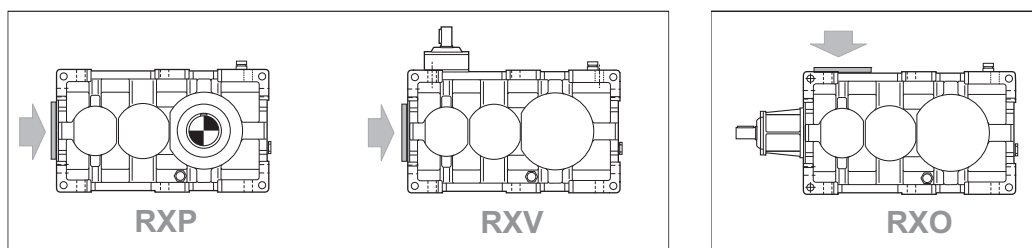
Standard

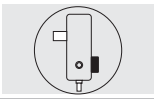



7.0 - Flangia freno (a disegno cliente)

7.0 - Brake flange (made to customer drawing)

7.0 - Bremsenflansch (gemäß Kundenzeichnung)

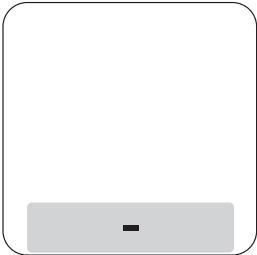
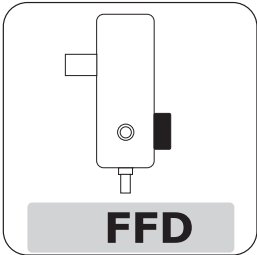
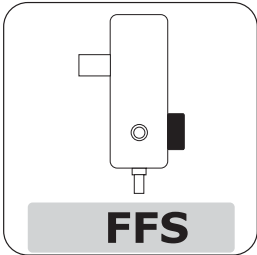
ACC9B	Accessori generali - Flangia freno	Accessories custom - Brake Flange	Zübehör custom - Bremsflansch
--------------	-----------------------------------------------	----------------------------------------------	------------------------------------------

 -	 FFD	 FFS
PMG - GEARBOX		
		





7.0 - Flangia freno (a disegno cliente)

FF.

A richiesta è possibile una predisposizione per poter assemblare direttamente diverse tipologie di freno al riduttore.

7.0 - Brake flange (made to customer drawing)

Custom mounting flanges to accommodate different types of brakes can be supplied on request.

7.0 - Bremsenflansch (gemäß Kundenzeichnung)

Auf Anfrage können die Getriebe so ausgelegt werden, dass unterschiedliche Bremstypen direkt am Getriebe montiert werden können.

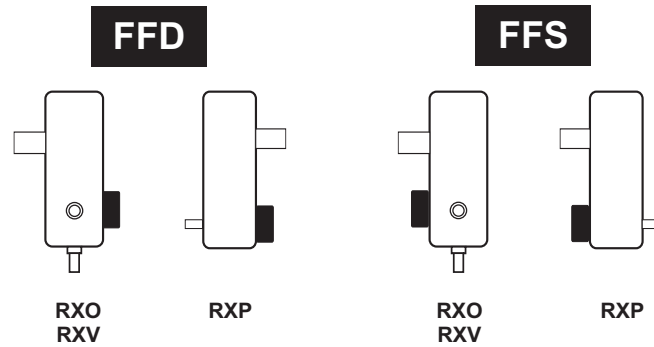



8.0 - Base porta motore

8.0 - Motor mount



8.0 - Motorauflage

ACC9C

**Accessori generali -
Base motore**

**Accessories custom -
Motor Mount**

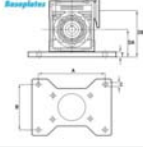
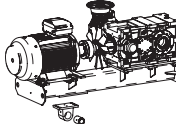
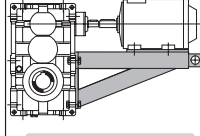
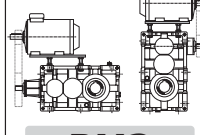
**Zübehör custom -
Motorbasis**

-	 BM0	 BMPLATE
 BM1		
 BM2		
 BM3		
<p>PMG - GEARBOX</p> 		

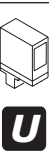

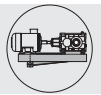

8.0 - Base porta motore

8.0 - Motor mount

8.0 - Motorauflage

8.1 - Applicabilità

8.1 - Application

8.1 - Applikation

	RXP	RXO	RXV
BM0 - Size IEC	to define - on request		
BM1 - Size IEC			
BM2 - Size IEC			
BM3 - Size IEC			

A richiesta sono disponibili 3 tipologie di basi porta motore. Nelle figure a seguito sono illustrate le forme costruttive delle 3 famiglie principali di questo prodotto. Nelle tipologie BM1 e BM2 sono fornibili come connessioni tra motore e riduttore giunti idrodinamici e giunti elastici, eventualmente equipaggiati con dischi a freno.

Three types of motor mounts are available on request. The diagrams below show three major families of motor mount products. On request, fluid and flexible couplings, also equipped with brake discs, are provided with types BM1 and BM2.

Auf Anfrage sind 3 Typologien von Motorauflagen verfügbar. Auf den folgenden Abbildungen werden die Bauformen der drei Hauptfamilien dieses Produkts illustriert. Die Typologien BM1 und BM2 können als Verbindungen zwischen Motor und Getriebe als hydrodynamische und elastische Kupplungen, eventuell mit Scheibenbremsen ausgestattet geliefert werden.

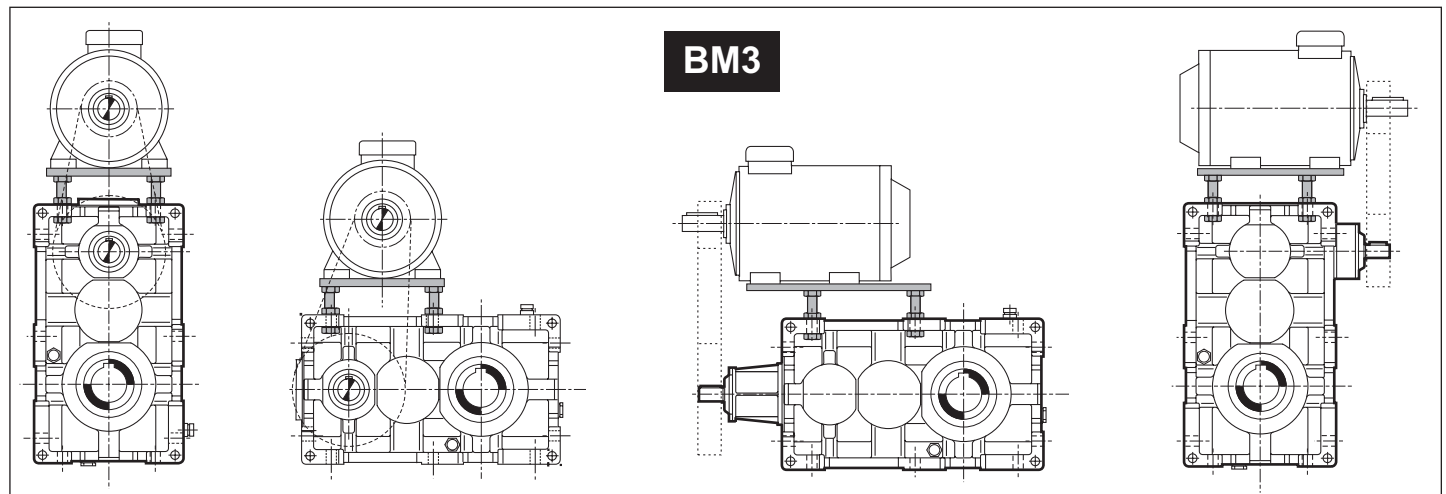
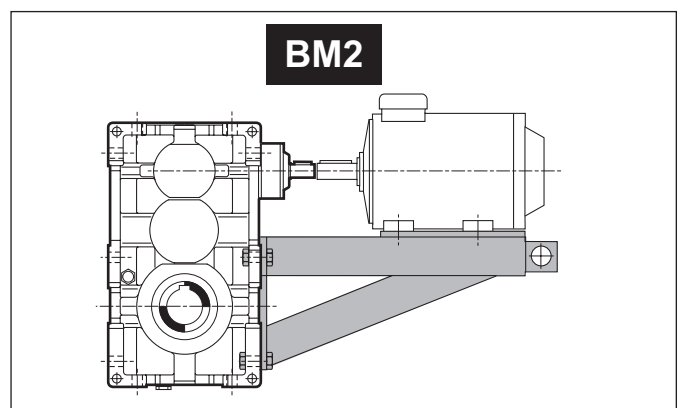
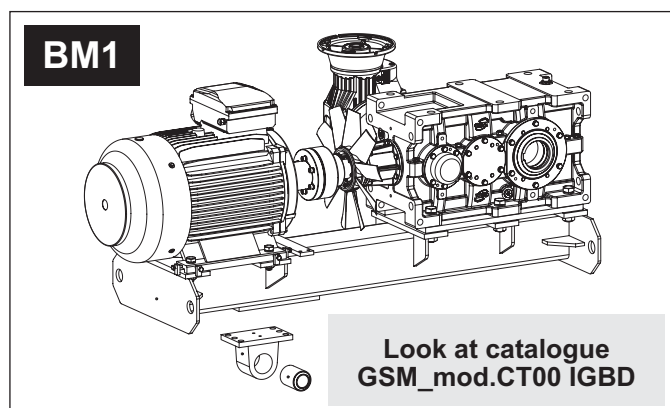

Bussolle in VKL

A richiesta le basi di tipologia BM1 e BM2 sono equipaggiabili con bussolle in VKL. A seguito le dimensioni delle bussolle in corrispondenza alla taglia del riduttore.

VKL bush

On request, motor mounts BM1 and BM2 can be equipped with VKL bushes. Bush dimensions for the different gear unit sizes are given in the table.

VKL-Buchsen

Auf Anfrage können die Typologien BM1 und BM2 mit VKL-Buchsen ausgestattet werden. Nachstehend die für die Getriebegrößen passenden Buchsenmaße.

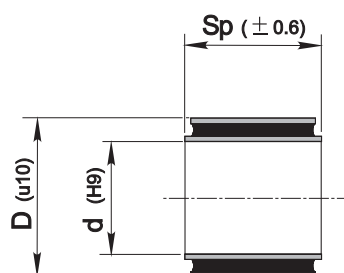

	D	d	Sp
808	65	40	88
810			
812	80	50	110
814			
816	140	100	120
818			
820	160	110	180
822			

9.0 - ESTREMITÀ SUPPLEMENTARI

9.0 - ADDITIONAL SHAFT EXTENSIONS

9.0 - ZUSÄTZLICHE WELLENENDEN

A richiesta è possibile fornire riduttori con estremità supplementari, in tali casi deve essere indicata la designazione dell'ES (estremità supplementare) come indicato in seguito.

On request, gear units are available with additional shaft extensions; please specify the designation of the required ES (additional shaft extension) as outlined below.

Auf Anfrage können die Getriebe mit zusätzlichen Wellenenden geliefert werden, in diesen Fällen muss wie folgt die Bezeichnung ES (steht für zusätzliches Wellenende) angegeben werden.

Designazione / Designation / Bezeichnung

RXO-RXV - [1] - [20] - Section B	RXO-RXV - [20]	RXO-RXV-[20a]	RXO-RXV-[20b]	RXO-RXV-[20c]	RXO-RXV-[20d]
RXP - [1] - [21] - Section A	RXP - [21]	RXP - [21a]	RXP - [21b]	RXP - [21c]	RXP - [21d]
	ES	2	DX	506	PAM132
	ES	1 - 2 - 3	DX - SX	Rapporto reale dall'estremità supplementare	ECE ECES PAM.. PAM..G

20	ASE - Presenza di un'estremità supplementare	ASE - Additional shaft extension fitted	ASE - Ein zusätzliches Wellenende vorhanden
21			

ES

20a	AWASE - Asse dov' è presente l'estremità	AWASE - Axis where additional shaft extension is located	AWASE - Achse an der ein zusätzliches Wellenende vorhanden ist
21a			

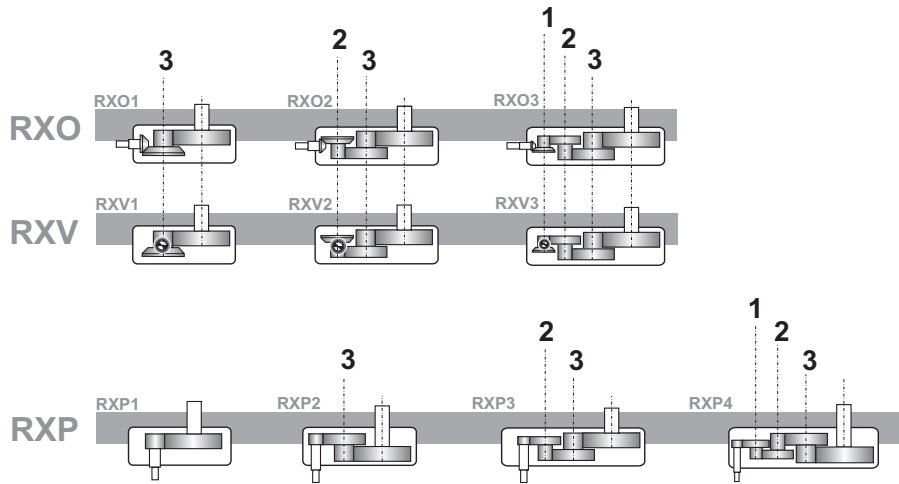

20b	ASES - Lato estremità supplementare supplementare	ASES - Additional shaft extension side	ASES - Seite des zusätzlichen Wellenendes
21b			

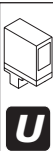
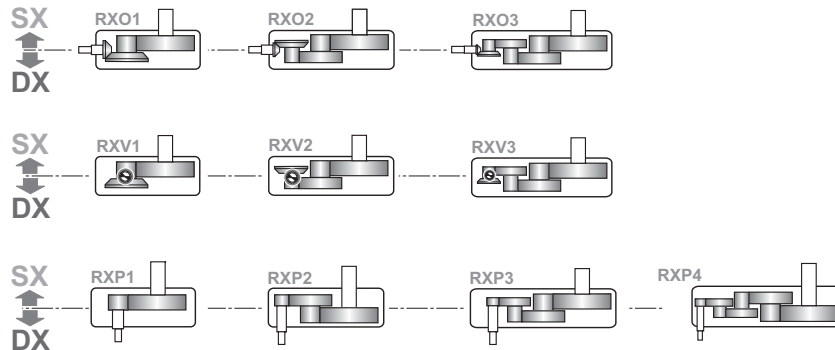

9.0 - ESTREMITÀ SUPPLEMENTARI

9.0 - ADDITIONAL SHAFT EXTENSIONS

9.0 - ZUSÄTZLICHE WELLENENDEN

20c IRASE - Rapporto reale del riduttore dalla estremità supplementare

IRASE - Actual gear ratio of gear unit from additional shaft extension

IRASE - Reelles Übersetzungsverhältnis am zusätzlichen Wellenende

Comunicato da GSM su richiesta.

Information available from GSM on request.

Gibt GSM auf Anfrage an.

20d ASET - Tipologia di estremità supplementare

ASET - Additional shaft extension type

ASET - Typ des zusätzlichen Wellenendes

21d

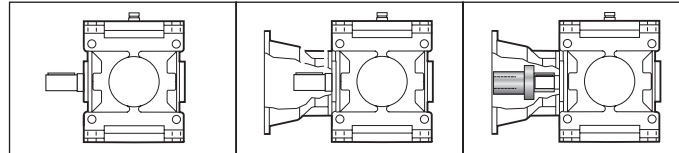

ECE

PAM..

PAM..G

ECE	Entrata con albero pieno	Solid input shaft	Antrieb mit Vollwelle
ECES	Entrata con estremità speciale (disponibile a richiesta)	Special input shaft end (available on request)	Antrieb mit speziellem Wellenende (auf Anfrage verfügbar)
PAM..	Con campana senza giunto	Motor bell without coupling	Mit Glocke ohne Kupplung
PAM..G	Con campana e giunto	Motor bell and coupling	Mit Glocke und Kupplung

Dimensioni

Dimensions

Applizierbare Motoren

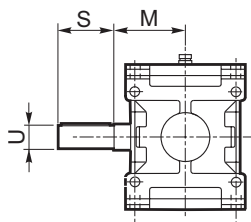

Grandezza Size Größe	Tipo Type Typ	Asse / Axis / Achse								
		1			2			3		
		U	S	M	U	S	M	U	S	M
802	RXO1-RXV1	—	—	—	—	—	—	35 k6	63	137
	RXP2	—	—	—	—	—	—	35 k6	63	109
	RXO2-RXV2-RXP3	—	—	—	28 j6	50	109	35 k6	63	109
	RXO3-RXV3-RXP4	22 j6	40	109	28 j6	50	109	35 k6	63	109
804	RXO1-RXV1	—	—	—	—	—	—	40 k6	70	151
	RXP2	—	—	—	—	—	—	40 k6	70	121
	RXO2-RXV2-RXP3	—	—	—	32 k6	56	121	40 k6	70	121
	RXO3-RXV3-RXP4	24 j6	45	121	32 k6	56	121	40 k6	70	121
806	RXO1-RXV1	—	—	—	—	—	—	45 k6	80	170
	RXP2	—	—	—	—	—	—	45 k6	80	137
	RXO2-RXV2-RXP3	—	—	—	35 k6	63	137	45 k6	80	137
	RXO3-RXV3-RXP4	28 j6	50	137	35 k6	63	137	45 k6	80	137
808	RXO1-RXV1	—	—	—	—	—	—	50 k6	90	192
	RXP2	—	—	—	—	—	—	50 k6	90	151
	RXO2-RXV2-RXP3	—	—	—	40 k6	70	151	50 k6	90	151
	RXO3-RXV3-RXP4	32 k6	56	151	40 k6	70	151	50 k6	90	151
810	RXO1-RXV1	—	—	—	—	—	—	55 m6	100	216
	RXP2	—	—	—	—	—	—	55 m6	100	170
	RXO2-RXV2-RXP3	—	—	—	45 k6	80	170	55 m6	100	170
	RXO3-RXV3-RXP4	35 k6	63	170	45 k6	80	170	55 m6	100	170
812	RXO1-RXV1	—	—	—	—	—	—	60 m6	112	242
	RXP2	—	—	—	—	—	—	60 m6	112	192
	RXO2-RXV2-RXP3	—	—	—	50 k6	90	192	60 m6	112	192
	RXO3-RXV3-RXP4	40 k6	70	192	50 k6	90	192	60 m6	112	192
814	RXO1-RXV1	—	—	—	—	—	—	70 m6	125	273
	RXP2	—	—	—	—	—	—	70 m6	125	216
	RXO2-RXV2-RXP3	—	—	—	55 m6	100	216	70 m6	125	216
	RXO3-RXV3-RXP4	45 k6	80	216	55 m6	100	216	70 m6	125	216
816	RXO1-RXV1	—	—	—	—	—	—	80 m6	140	302
	RXP2	—	—	—	—	—	—	80 m6	140	242
	RXO2-RXV2-RXP3	—	—	—	60 m6	112	242	80 m6	140	242
	RXO3-RXV3-RXP4	50 k6	90	242	60 m6	112	242	80 m6	140	242
818	RXO1-RXV1	—	—	—	—	—	—	90 m6	160	273
	RXP2	—	—	—	—	—	—	90 m6	160	273
	RXO2-RXV2-RXP3	—	—	—	70 m6	125	273	90 m6	160	273
	RXO3-RXV3-RXP4	55 m6	100	273	70 m6	125	273	90 m6	160	273
820	RXO1-RXV1	—	—	—	—	—	—	100 m6	180	302
	RXP2	—	—	—	—	—	—	100 m6	180	302
	RXO2-RXV2-RXP3	—	—	—	80 m6	140	302	100 m6	180	302
	RXO3-RXV3-RXP4	60 m6	112	302	80 m6	140	302	100 m6	180	302

9.0 - ESTREMITÀ SUPPLEMENTARI

9.0 - ADDITIONAL SHAFT EXTENSIONS

9.0 - ZUSÄTZLICHE WELLENENDEN

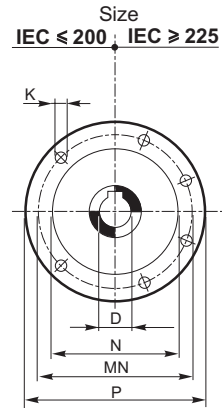
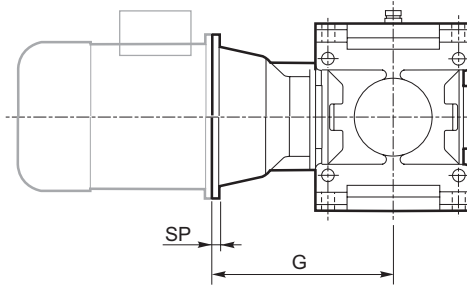
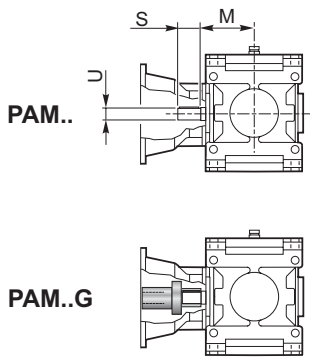

Asse / Axis / Achse 1

		IEC												
		80	90	100	112	132	160	180	200	225	250	280	315	355
D H7		19	24	28	28	38	42	48	55	60	65	75	80	100
P		200	200	250	250	300	350	350	400	450	550	550	660	800
MN		165	165	215	215	265	300	300	350	400	500	500	600	740
N G6		130	130	180	180	230	250	250	300	350	450	450	550	680
K		M10	M10	M12	M12	M12	M16	M16	M16	M16	M16	M16	M16	M20
SP		12	12	14	14	16	18	18	20	20	20	20	24	30
G	802		203	213	213	233	263	263	263					
	804			230	230	250	280	280	280	310				
	806			251	251	271	301	301	301	331				
	808			271	271	291	321	321	321	351	351	351		
	810					317	347	347	347	377	377	377	407	
	812					346	376	376	376	406	406	406	436	
	814						410	410	410	440	440	440	470	
	816						446	446	446	476	476	476	506	546
	818								487	517	517	517	547	587
820									558	558	558	588	628	

Asse / Axis / Achse 2

		IEC												
		80	90	100	112	132	160	180	200	225	250	280	315	355
D H7		19	24	28	28	38	42	48	55	60	65	75	80	100
P		200	200	250	250	300	350	350	400	450	550	550	660	800
MN		165	165	215	215	265	300	300	350	400	500	500	600	740
N G6		130	130	180	180	230	250	250	300	350	450	450	550	680
K		M10	M10	M12	M12	M12	M16	M16	M16	M16	M16	M16	M16	M20
SP		12	12	14	14	16	18	18	20	20	20	20	24	30
G	802				223	243	273	273	273					
	804						291	291	291	321				
	806						314	314	314	344				
	808						335	335	335	365	365	365		
	810								364	394	394	394		
	812									426	426	426	456	
	814										460	460	490	530
	816											498	528	568
	818											542	572	612
820												616	656	

Le altre dimensioni dei riduttori potranno essere reperite nelle corrispondenti sezioni RXP e RXO.

For gear unit dimensions not covered here, please see the relevant RXP and RXO sections.

Die weiteren Abmessungen der Getriebe können den jeweiligen Abschnitten RXP und RXO entnommen werden.

10.0 - CAMBI DI VELOCITÀ

A richiesta è possibile fornire riduttori con cambio di velocità, in tali casi, nelle designazioni dei riduttori RXP e RXO riportate nelle rispettive sezioni, in corrispondenza di ir (colonna [IR] deve essere riportato 2V, 3V, ... (numero di marce desiderato e rapporto reale delle rispettive marce) come indicato in seguito.

I riduttori con cambio di velocità presentano un gioco angolare in inversione di moto di diversi gradi angolari. Il gioco angolare è dovuto al profilo speciale a coda di rondine che GSM utilizza nella trasmissione del moto tra innesto e ingranaggio.

Nelle applicazioni con cicli ad inversione del moto nelle quali il gioco angolare richiesto sia inferiore a 20' contattare il nostro Servizio Tecnico.

10.0 - GEAR SHIFT

Gear-shift drives are available on request; when designating RXP and RXO gear units as outlined in the relevant sections, specify number of speeds and actual gear ratios (2V, 3V, ...) under item ir (column [IR]) as outlined below.

The shift gearboxes have a backlash on reversal of angular motion of different degrees. The backlash is due to the special profile dovetail which uses GSM in the transmission of motion between the selector and gear.

In applications with inversion of cycles in which the backlash required is less than 20', please to contact our Technical Service

10.0 - SCHALTGETRIEBE

Auf Anfrage können Schaltgetriebe geliefert werden, in diesen Fällen muss unter den Bezeichnungen der RXP- und der RXO-Getriebe in den jeweiligen Abschnitten, unter der Angabe ir (Spalte [IR]) 2V, 3V, ... angegeben werden (Anzahl der gewünschten Gänge und reelles Übersetzungsverhältnis der Gänge); siehe nachstehende Angaben.

Die Wechselgetriebe verfügen über einen Umkehr-Winkelspielraum verschiedener Winkelgrade.

Der Winkelspielraum basiert auf dem speziellen Schwalbenschwanzprofil, das die GSM bei der Bewegungsübertragung zwischen der Kupplung und dem Getriebe nutzt.

Bei Anwendungen mit Umkehrzyklen bei denen der erforderliche Winkelspielraum unter 20' liegt, setzen Sie sich bitte mit unserem Kundendienst in Verbindung

Designazione / Designation / Bezeichnung

	IR		
	2V		
	2V-"ir"-"ir" 3V-"ir"-"ir"-"ir" ...		

Esempio / Example / Beispiel

RXP2/814/2V-7-14/ECES/N/M1

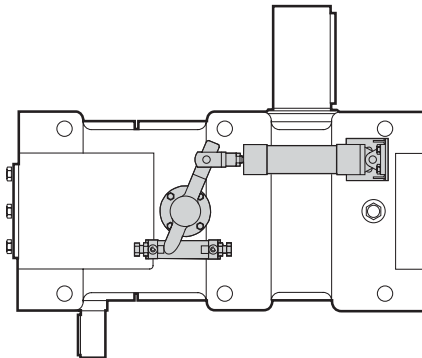
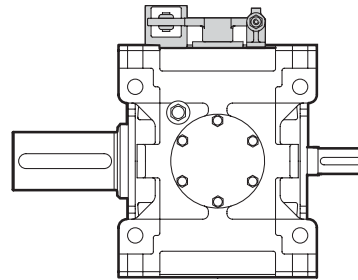
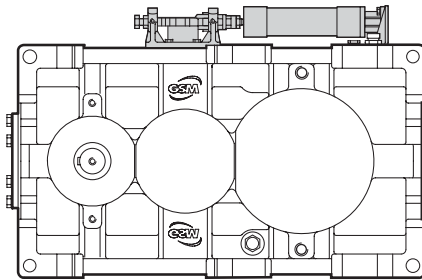

Per configurazioni disponibili, prestazioni e dimensioni contattare il servizio tecnico commerciale GSM.

Please contact GSM Sales Engineers for detailed information on available configurations, ratings and dimensions.

Die verfügbaren Konfigurationen, Leistungen und Abmessungen können in der Technischen Abteilung der STM angefragt werden.